

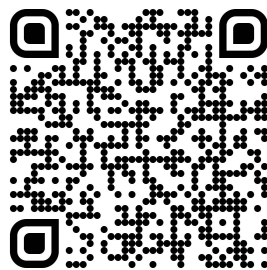

**Appalachia**  
SERVICE PROJECT®

# CONSTRUCTION MANUAL



Check out our Construction Training Videos!

# Acknowledgements

A very special thanks to Sarah Beth Shoemaker for her work creating and editing this manual; and to Shelby Mitchinson for her work creating the included diagrams. Without these friends this edition of the manual would not be possible.

It is with great gratitude we offer this manual to our many friends of Appalachia Service Project. Thank you for working with families to make their homes warmer, safer, and drier.

## Note to the Reader

This manual is written as a guide in construction methods and techniques used by Appalachia Service Project. Due to differing conditions, tools and individual skills, Appalachia Service Project assumes no responsibility for losses incurred, injuries suffered, or for any damages. Before beginning projects, please review project plans and instructions carefully. If any questions remain, please consult with your ASP staff, Construction Consultant, or the Ministries Department. Projects should always comply with local codes and regulations, and always follow safe work practices.

Appalachia Service Project welcomes comments and feedback about ways to improve this manual. Please contact us by any of these methods:

Write to:  
Appalachia Service Project  
Construction Manual  
4523 Bristol Highway  
Johnson City, TN 37601

Email:  
[constructionmanual@asphome.org](mailto:constructionmanual@asphome.org)



# Table of Contents

|  |            |
|--|------------|
| <b>Construction &amp; Tool Basics</b>                  | <b>3</b>   |
| <b>Girders &amp; Piers</b>                             | <b>17</b>  |
| <b>Floors</b>  | <b>29</b>  |
| <b>Walls, Windows, &amp; Doors</b>                     | <b>65</b>  |
| <b>Roofs</b>   | <b>89</b>  |
| <b>Soffit and Siding</b>                               | <b>133</b> |
| <b>Insulation, Vapor Barriers, &amp; Air Sealing</b>   | <b>157</b> |
| <b>Drywall</b>   | <b>167</b> |
| <b>Paint &amp; Trim</b>                                | <b>181</b> |
| <b>Drainage &amp; Gutters</b>                          | <b>197</b> |
| <b>Underpinning/Skirting &amp; Crawl Space Venting</b> | <b>209</b> |
| <b>Porches</b>   | <b>225</b> |
| <b>Ramps</b>   | <b>251</b> |
| <b>Mobile Homes</b>                                    | <b>279</b> |
| <b>Hug Systems</b>                                     | <b>285</b> |
| <b>Room Additions</b>                                  | <b>301</b> |





# Construction & Tool Basics

## Fasteners

**Interior Fasteners:** not made to withstand moisture and will rust quickly if exposed to moisture.

**Exterior Fasteners:** coated to be protected from moisture, galvanized fasteners are exterior fasteners.

## Nails

Nails are measured by “penny” which is represented by a lowercase “d.” The “d” indicates the length of the nail.

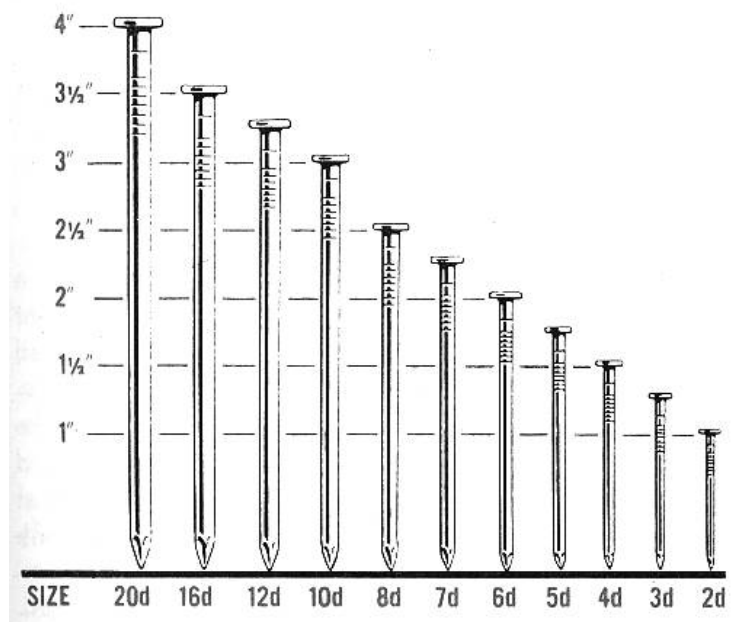

## Types of Nails

### **Finish Nails:**

- Used for trim (baseboard, door casing, etc.)
- Should be installed and then the head should be sunk  $\frac{1}{8}$ " below the surface using a nail punch so it can be covered with putty
- Pre-drilling before installing finish nails can prevent nails from bending
- Interior and exterior finishing nails available



### **Roofing Nails:**

- Used for attaching vinyl siding, vinyl soffit, vinyl underpinning, synthetic underlayment for roofing, shingles, some trim for metal roofing
- Come in a large range of length, 1  $\frac{1}{4}$ " - 2" will be adequate for most applications



### **Common Nails:**

- Used most commonly in wall framing
- Interior and exterior/galvanized common nails are available
  - Use galvanized with pressure treated lumber
  - Regular should be used with finished/white wood



### **Spiral Nails:**

- Most commonly used for attaching subfloor and deck boards for ramps/porches
- Has greater holding strength than common nails
- Interior and exterior spiral nails available



### **Ring Shank Nails:**

- Used where a solid hold is desired, very difficult to work loose
- Used for attaching subfloor and deck boards for ramps/porches
- Has greater holding strength than common nails
- Interior and exterior ring shank nails available



### **Aluminum Trim Nails:**

- Used to attach metal fascia and during vinyl siding to help hold partial cut pieces
- All exterior



### **Joist Hanger Nails:**

- Used to attach joist hanger, hurricane ties, post boots, connection plate (See below)
- For exterior and interior use



## **Screws**

### **Screw Heads**

Screws come with a variety of types of heads that have specific drivers to fasten them

#### **Phillips:**



- Phillips drivers come in different sizes, the most common is #2

#### **Hex:**



- Hex drivers come in different sizes, the most common are 1/4" and 5/16"

#### **Torx:**



- Torx drivers come in different sizes, the most common are T-25 and T-40

## Types of Screws

### Deck Screws:

- Used for porches/ramps
- Can also be used for framing, floor repairs
- Comes in a variety of lengths with torx heads of varying sizes
- Most commonly used are 2 ½" and 3", which both have T-25 heads
- All exterior rated, can be used inside as well



### Drywall Screws:

- Used to hang drywall, can also be used to fasten flooring underlayment
- Come in a variety of lengths, 1 ½" - 2" should be adequate for most applications
- Have phillips heads
- For drywall, can be installed with a phillips dimpler bit that countersink the screw heads before mud is applied
- Only for interior use



### Neoprene Screws:

- Used to install metal roofing and metal underpinning
- Have a neoprene gasket that make a watertight seal
- Have hex heads, most commonly ¼" or 5/16"
- Come in a variety of lengths, 1 ¼" - 2" should be adequate for most applications



## Other Fasteners

### Ledger Loks:

- Used for porches and ramps
- Have either hex (typically 5/16") or torx (typically T-40) heads
- For exterior and interior use
- Come in a variety of lengths, 3 ½" - 4 ½" should be adequate for most applications



**Trim Screws:**

- Used as an alternative to finish nails
- Come in a variety of lengths, 2" should be used
- Most have torx heads, typically T-10



**Concrete Screws:**

- Used to fasten brackets to concrete or attach lumber to concrete
- For exterior or interior use
- Hole must be pre-drilled using a hammer drill and masonry bit
- Come in a variety of lengths and widths, the package will list needed size of pilot hole
- Have either hex or phillips bits

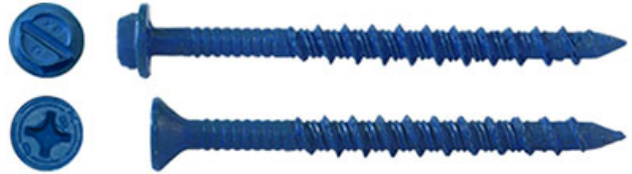

**Carriage Bolts:**

- Used to attach piers to floor system in room addition.
- Come in both interior grade and galvanized for exterior use
- Hole must be drilled before bolt is installed, a 1/16" larger hole than the diameter of the bolt
- Come in a variety of widths and lengths for different applications
- Nut and washer sizes should coordinate to bolt size



**Concrete Anchor:**

- Used with a post boot (see below) to connect a post to concrete or to attach dimensional lumber to concrete
- Hole must be pre-drilled in concrete with a hammer drill and masonry bit
- Come in a variety of lengths and sizes, depending on application
  - Packaging will indicate size of pre-drill needed
- 1/2" x 3 3/4" can be used to attach a post boot or to attach 2x material to concrete



# Connection Pieces

## Joist Hangers:

- Used to hang joists for porches or floor systems
- Attached with joist hanger nails through the flat surfaces and 2 ½” screws or 8d nails through the diagonal holes
- Come in different sizes according to joist size

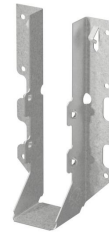

## Post Boots:

- Boots used to anchor the bottom of the post to concrete
- There are a variety of types of post boots that connect into wet concrete or hardened concrete and a concrete anchor is used to make the connections

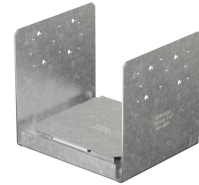

## Connection Plates:

- Used during band joist repair
- Helps reinforce holding power where a flat surface is necessary
- Attach with joist hanger nails



## Hurricane Ties:

- Used to attach rafters to walls, girders to floor systems, and other connections
- Attached with joist hanger nails
- 3 holes of each surface should be filled



# Fastening Information

- Determine the size of fastener needed:
  - For most cases, use a fastener twice as long as the width of the smaller material
  - Choose a fastener that will not stick all the way through the second piece of wood
- When fastening two pieces, fasten through the thinner material first
  - *For example, fasten through the subfloor into the floor joist or through the deck board into the porch joist*
- Toe Nailing/Toe Screwing
  - Fastening nails or screws at an angle to hold piece of wood together
  - Start fastener perpendicular to the surface, once it breaks the surface, move it to the correct angle and finish driving in fastener
  - Pre-drilling can help ensure direction of toe-nail/screw

# Tools

## Ladders

### Extension Ladders:

- Set up at a 1:4 ratio, with 1' away from the wall for every 4' of height
  - When your feet are planted at the base of the ladder, you should be able to reach your arms out straight and touch the sides of the ladder
- Both feet should be firmly on the ground
  - If the ground is uneven, use a shovel or claws of a hammer to dig out for the feet so that they sit flat
  - Make sure the section of ladder with feet is closer to the home
- If using extension ladder to access roof, 3' or 3 rungs of the ladder should be extended above the eave of the roof
- Always face the ladder while climbing
- Another person should hold the bottom of the ladder when it is in use
- When working from an extension ladder, never reach so far that your belt buckle will be outside of the width of the ladder



### A-Frame Ladders:

- Lock bars should be all the way down when A-frame ladders are in use
- If using ladder on uneven ground, use a shovel or hammer claws to dig out the ground so that the ladder sits flat, with all 4 feet on the ground
- Do not stand or sit on the top of an a-frame ladder
- Do not stand on the last rung before the top of the ladder
- Always face the direction of the ladder, do not work backwards from an a-frame ladder
- Do not leave items sitting on top of an a-frame ladder, they can easily fall on someone who picks up the ladder





## **Power Tools:**

- Use proper safety equipment when using or working around someone using power tools
- Youth should be supervised by adults when operating power tools
- Unplug when not in use
- Unplug when changing blade
- If the cord of a tool is damaged, do not use it
- Do not use power tools in the rain, make sure electrical connections are dry if the ground is wet
- Use only battery powered tools on roofs - cords create tripping hazards

### **Circular Saw:**

- Used to cut sheet goods (OSB, paneling, lauan)
- Can be used to cross cut 2x material, but the miter saw, if available, will give a more controlled cut
- For safe operation the saw depth should be set to the thickness of the material being cut
  - Unplug while adjusting
- The saw can adjust to cut angles
- Unplug and clean out any sawdust build up that occurs in the saw
- Come corded or cordless
- There are different types of blades that can be used with a circular saw, depending on the material being cut
  - General Use Wood Blade - used for cutting plywood, OSB, 2x Material
  - Finishing Blade - used for finer cuts on materials like paneling, laminate flooring, 1x trim
  - Metal Cutting Blade - used to cut metal roofing, metal underpinning panels, and rebar

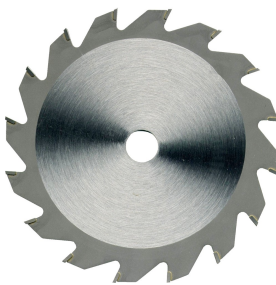

Wood Blade



Finishing Blade

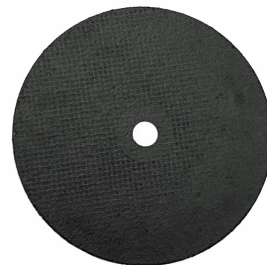

Metal Cutting Blade



### **Miter Saw:**

- Used to make straight or angled cuts on 2x material or tim
- Miter saws have a rotating lock that allow the angle of the cut to be adjusted
- Compound miter saws make angle cuts in two planes
- Piece of lumber has to be flat on the saw table and pushed back against the fence when cuts are made to achieve the desired angle
- Miter saws come in different sizes - these sizes dictate the size of the saw blade they hold (8", 10", and 12")
  - Make sure replacement blades are the appropriate size
- A miter saw can have a General Purpose Wood Blade or a Finishing Blade (as in the circular saw section above)
  - Metal cutting blades should not be put on a miter saw



### **Reciprocating Saw:**

- Used largely for demolition stages, does not make particularly accurate cuts
- Come corded or cordless
- Resting the guard on the saw against the material being cut reduces vibration
- Can cut wood or metal
  - Blades come in different lengths depending on application
  - Different types of blades:
    - Wood Cutting Blade - cutting wood only
    - Demolition/Bi-Metal Blades - cutting through wood that contains nails
    - Metal Cutting Blades - cutting rebar



### Jigsaw:

- Used for cutting thin sheet material at curves or finishing corners of cuts
  - Good for cutting out holes for vents in subfloor or notching deck boards around posts
  - If needed, pilot holes (larger than blade) should be drilled to give the jigsaw a starting point to cut out the shape
- There are two types of jigsaws: T-shank and U-shank
  - Saws will hold blades that are one shape or the other, not both
  - Metal and wood blades come with both types of shanks
  - U-shank blades are shown in top image below
  - T-shank blades are shown in bottom image below
- Jigsaws can cut wood or metal (only thin sheet metal)
  - A wood cutting blade is shown in the following top image
  - A metal cutting blade is shown in the following bottom image



### Table Saw:

- Used to make long, straight cuts with the grain of the wood
- Can cut at angles
- The height of the blade above the table should be adjusted to the thickness of the wood being cut
- Push sticks should always be available and used when making cuts with the table saw
- Two people should work together when cutting on a table saw, one sending the piece through and the other receiving
- Never use a table saw that does not have a guard



## Drills/Impact Drivers:

- Used to fasten screws or drill holes
- Drills can be corded or cordless (left side image below), impact drivers are all cordless (right image below)
  - Corded drills are typically more powerful
  - Cordless drills/impact drivers allow greater mobility
- Hammer drills are used to drill holes in concrete using masonry bits
  - Most hammer drills also have a regular drill setting
- Impact drivers can only use drivers/bits with a 1/4" hex shank
  - There are bits for drilling holes with hex shanks, but they are more expensive and can be difficult to find
- Drills can use both traditional drill bits and drivers/bits with 1/4" hex shanks



- Drill Bits



A



B



C



D

- (A) Traditional Bit - Can come to drill in metal or wood, come in diameters up to 1/2" and in varying lengths
- (B) Masonry Bit - Used to drill holes in masonry (concrete, brick, masonry, etc.)
- (C) Paddle/Spade Bit - Used for boring holes up to 1 1/2" in wood
- (D) Hole Saw - Used for cutting holes from 1 1/2" - 6" wood cutting and metal cutting hole saws are available





# Girders & Piers

**Why girders, piers, and foundations?** Girders and piers are important to a home's foundation and help maintain stability of the floor system, making the home safe and longlasting for homeowners.

## Safety

- Beware of the conditions under the home (snakes/bees/animals, waste water, etc.)
- Make note of any pipes/wires running underneath the home
- Wear eye protection when cutting with power saws or working close by
- Make sure temporary supports are holding the weight of the girder while concrete dries

## Girder/Pier Project Planning

- How will you access underneath the house?
- Is there enough room for volunteers to work?
- Is it safe for volunteers to be under the home?
- Are current joists overspanned? (Span chart on page 28)
- Will you be working on the subfloor as well? Should work be done from top or bottom?
- Will you need to build the girder in place (under the house) or is there room to build it outside and then move it in?
- How many piers will you need per girder? 4x4s or 6x6s?
- Where will water to mix concrete come from?
- How close will the girder be to the ground? If within 12", pressure treated lumber should be used.

## Measurements Needed

- How long of an area needs to be supported/how many girders are needed?
  - 16' is the maximum length for a girder, if the area to be supported is greater than 16' use 2 separate girders
- Determine post size and length
  - If the space between the ground and the bottom of the floor joists is 60" or less, use a 4x4 post
  - If the space between the ground and the bottom of the floor joists is greater than 60", use a 6x6 post

## **Quality Control**

- Check nailing pattern on both sides of girder
- Make sure that all seams of materials in the girder are staggered (OSB and 2xs)
- Make sure joists are resting on girder (if not, make sure they are shimmed or blocks are added until there is contact with a joist)
- Make sure hole is 16"x16"x16" and 8" of concrete is poured in the bottom of the hole (up to bottom of the post)
- Make sure pier and girder are properly connected with gusset plate or simpson tie
- Make sure joists are attached to girders with hurricane straps, every 3rd joist
- If working from the top and also installing new joists, make sure that the girder is set at the correct height so that when joists, subfloor, and finished floor are added the finish height will be the same as the original level in adjoining rooms

## **Common Mistakes**

- Girder in place, but not touching and supporting all joists
- Post submerged deep into the concrete
- Pier to girder connected only with toe-screws
- Posts not plumb underneath girder
- Girder weight not adequately held by temporary supports

## **After Work is Complete Quality Control Check**

- Is everything secured properly? Posts to girders, girders to joists
- Are there enough piers?
- Are temporary supports removed after concrete dries?

## **Group Leader Tips**

- If there is limited space under the home, you can mark where girder will go and dig holes before putting the girder in place so there is a little more head room while digging
- Have a lot of hands on deck for getting the girder in place, they are heavy
  - Assign who will be holding/fastening and make sure everyone has what they need before getting girder into place

# Girder Instructions

A girder is a beam that runs perpendicular to the floor joists, held up by piers, and acts as a support for a floor structure.

## Construct Girder

- Cut strips of  $\frac{1}{2}$ " OSB down the 8' length that are  $6\frac{3}{4}$ " wide (if using 2x8) or  $\frac{1}{2}$ " narrower than the 2x material that will be used
  - These OSB strips will be sandwiched between the 2x8s (See Diagram 1)
- Diagram 1 illustrates a profile view of what the girder will look like when it is put together
  - Use construction adhesive between the OSB and 2x8 material on both sides (See Diagram 2)
  - Determine which edge will be the top of the girder (that contacts the floor joists) and make sure that the 2x8 pieces are even/parallel on that edge

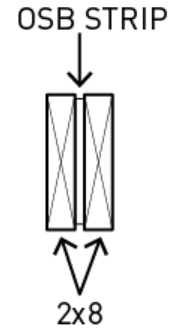

DIAGRAM 1

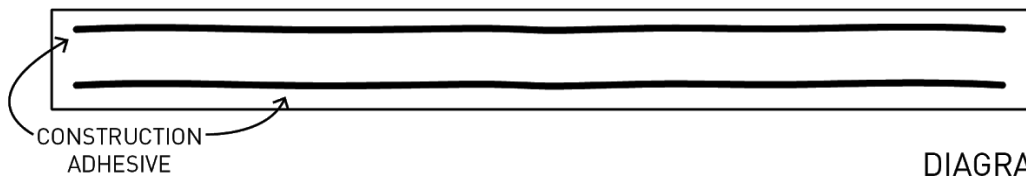

DIAGRAM 2

- Use full length pieces of 2x8 if possible - if it is necessary to use more than one piece of 2x8 on a single side, make sure that seams do not line up. (See Diagram 3)
  - Allow for a minimum 2' overlap

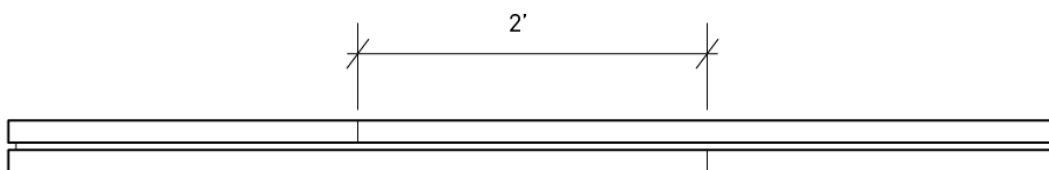

DIAGRAM 3

- Fasten the pieces of the girder together with 3" exterior screws or 16d galvanized nails
  - Diagram 4 shows the fastening pattern for the girder
    - Note that the pattern is opposite on each side of the girder

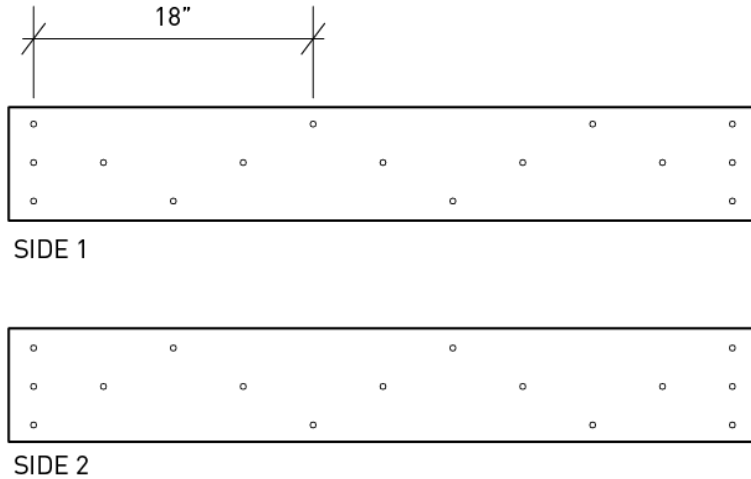

DIAGRAM 4

## Install Girder

- To get the girder into place against the floor joists, temporary supports will be needed
  - Diagram 5 shows a possible temporary support for the girder
  - Concrete blocks and scrap lumber can also be used to hold the girder, as long as they hold the girder in place while the concrete sets
- Hang the girder from the floor joists using hurricane straps secured with joist hanger nails or exterior screws (See Diagram 6)
  - Put one hurricane strap on each side of the girder on every 3rd floor joist (See Diagram 7)
  - Fill 3 holes of each hurricane strap on both the girder and joist

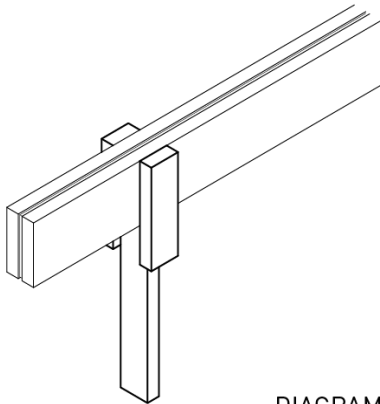

DIAGRAM 5

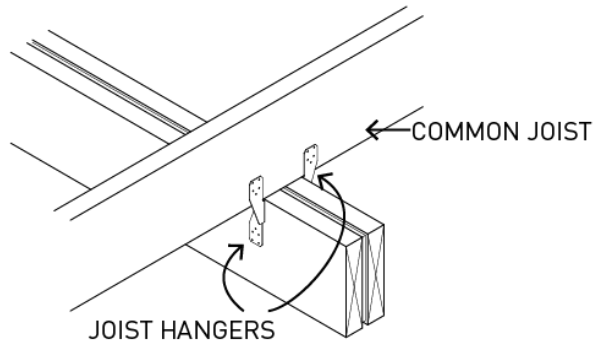
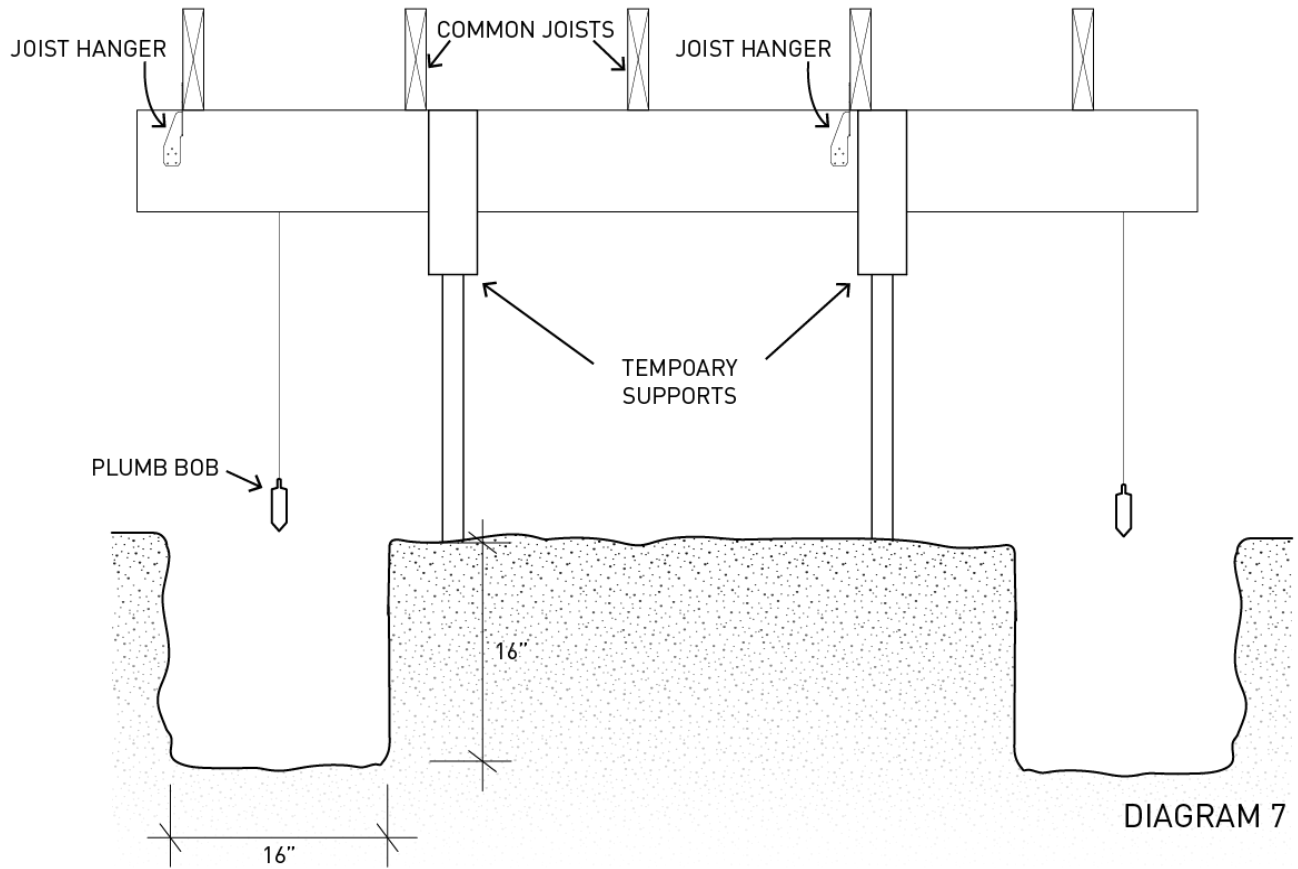
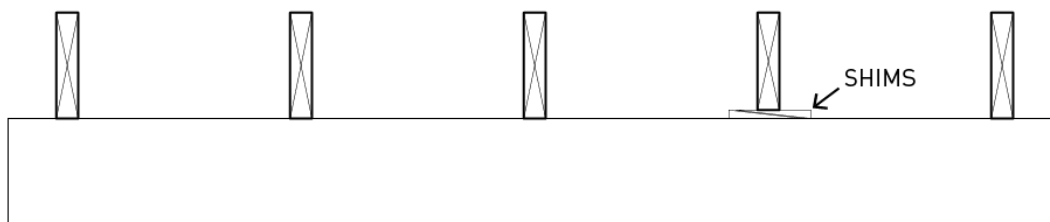

DIAGRAM 6





- If any of the floor joists are not in contact with the girder:
  - Do not notch the floor joist
  - If the gap is small enough, place shims in the gap (See Diagram 8)
  - If the gap is too large for shims, use a 2x4 or 2x6 around 4' long attached beside the floor joist and resting on top of the girder (See Diagram 9)
  - This step can be completed at any time after girder is in place



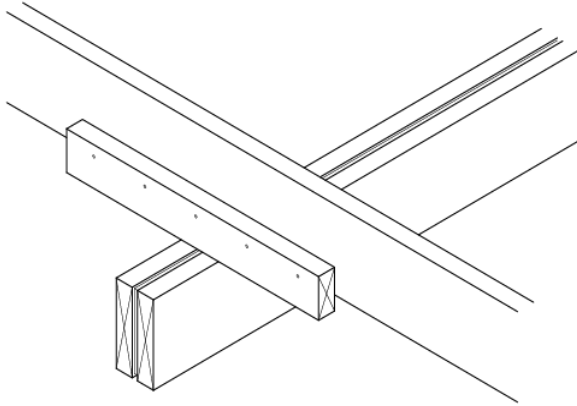

DIAGRAM 9-A

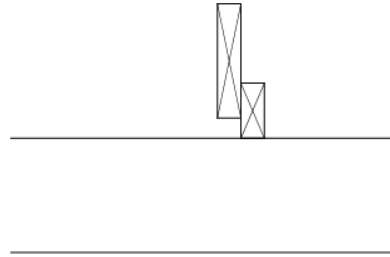

DIAGRAM 9-B

### Prepare footings

- Posts will be installed underneath the girder to hold it into place, each post will rest on a concrete footing
  - Posts supporting the girder should be every 8' at the maximum
- Mark on the bottom of the girder where posts will attach
- Hang a plumb bob from where the center of the post will touch the girder and make a mark on the ground
  - This mark will be the center of the hole for the post's footing (See Diagram 7)
- Each hole will be 16"x16"x16" (See Diagram 10)
- Digging under home, short shovels or garden trowels may work best

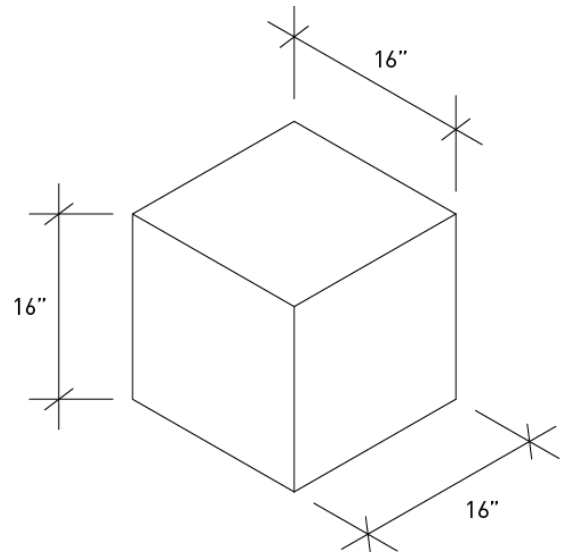

DIAGRAM 10

## Install Posts

- If the space between the ground and the bottom of the floor joists is 60" or less, use a 4x4 post and if the space between the ground and the bottom of the floor joists is greater than 60", use a 6x6 post
- When the girder is in place, measure from the bottom of the girder to the ground surface and add 8", cut post to this length, do this for each post of the girder
- Hang posts with gusset plates
  - Gusset plates are used to tie the girder and posts together (See Diagram 11)
  - Cut gusset plates out of 1/2" OSB
  - Dimensions of the gusset plate are 6" (bottom) x 12" (top) x 12" (height)
  - Glue the gusset plate to the girder with construction adhesive
  - Attach the gusset plates to both sides of the girder at each post with exterior screws (See Diagram 11)
  - Install the post between the two gusset plates, making sure it is plumb

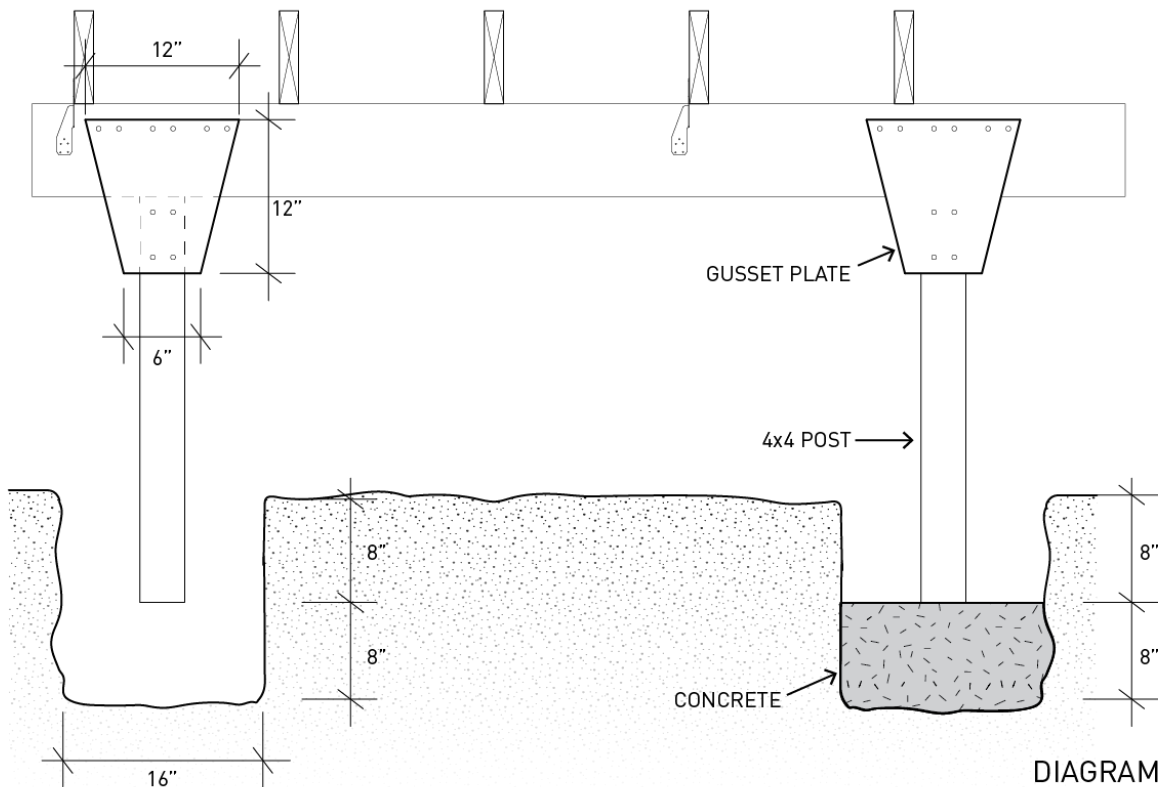

DIAGRAM 11

## Pour Concrete

- Mix and pour 8" of concrete in hole up to the bottom of the post (See right side of Diagram 11)
- Let concrete set overnight before filling the remainder of the hole with dirt and tamping
- Leave temporary supports in place until concrete has set overnight, then remove them

## **Girder Material List**

| <u>Quantity</u> | <u>Item</u>           | <u>Purpose/Notes</u>  |
|-----------------|-----------------------|---|
| ___             | 2x8x___ PT            | For girder  |
| ___             | 1/2" OSB              | Center strips in girder and gusset plates                           |
| ___             | 4x4x___ PT (or 6x6)   | Posts to support girder   |
| ___             | 2x4x8 White Wood      | Temporary supports for the girder                                   |
| ___             | Bags of sackrete      | (3) 60lb bags per hole or (2) 80lb bags per hole                    |
| ___             | 2x4x8 PT              | Any additional blocking (if needed)                                 |
| ___             | Hurricane ties        | Both sides of girder for every 3rd joist                            |
| ___             | Joist hanger nails    | To attach hurricane ties  |
| ___             | 16d galvanized nails  | Or 3" Deck Screws, to fasten girder together                        |
| ___             | Construction adhesive | To glue girder components together and to attach gusset plates      |
| ___             | Shims                 | Used where common joist doesn't sit directly in contact with girder |

## **Recommended Tools**

### **Safety:**

Glasses  
 Gloves  
 Ear Plugs  
 Dust Masks  
 Tyvek Suits (based on conditions under home)

### **Power Tools:**

Circular Saw  
 Miter Saw  
 Drills/Impact Drivers  
 → T-25 Driver to match deck screws

### **Digging/Concrete Tools:**

Shovels (Short handles may be ideal under home)  
 Wheelbarrow or bucket to mix concrete  
 Trowels to mix/move concrete in bucket  
 Garden hoe to mix concrete in wheelbarrow  
 Hose/Extra bucket for water to mix concrete

### **General Tools:**

Basic Hand Tools (Tape measures, hammer, pencils, speed square, etc)  
 Saw Horses  
 Extension Cords/Splitters  
 Caulk Gun  
 Drop lights/flashlights

# Pier Instructions

Sonotubes can be used as an alternative to wooden piers for a girder in particularly damp locations or they can be used under I-beams on mobile homes that need support.

- Dig holes for each sonotube
  - Use a plumb bob from the girder/I-beam to determine where the center of each hole will be
  - Each hole will be 16"x16"x16" (See Diagram 10)
- To determine the height of the sonotube measure from the bottom of the girder/I-beam to ground level and add 8"
  - Cut sonotube to this length with a reciprocating saw and wood blade
- Cut a saddle into the sonotube 3" deep and the width of the girder/i-beam (See Diagram 12)
- Cut a 4"x4" door into the side of the sonotube near the top at a place where it will be most convenient for you to pour concrete into the sonotube (See Diagram 12)
- Put the sonotube in place making sure the saddle is tight to the bottom of the girder/I-beam and the sonotube is plumb (See Diagram 13)
  - Sonotube can be held into place using duct tape or scrap lumber
- Mix and pour concrete
  - Pour directly into the hole until concrete reaches the bottom of the sonotube, then start filling the tube through the cut door at the top (See Diagram 13)
  - Occasionally, tap the side of the tube to compact the concrete as it is poured
  - When you reach the door, tape the door shut using duct tape and finish filling the sonotube from the top
  - If able you can create a trough (using a wider diameter pipe or a piece of gutter) and pour the concrete into the sonotube from outside of the crawl space, otherwise a bucket and small shovel can be used underneath the house
- Let the concrete set overnight and then backfill dirt into the hole and tamp dirt tightly
  - Remove duct tape and temporary bracing

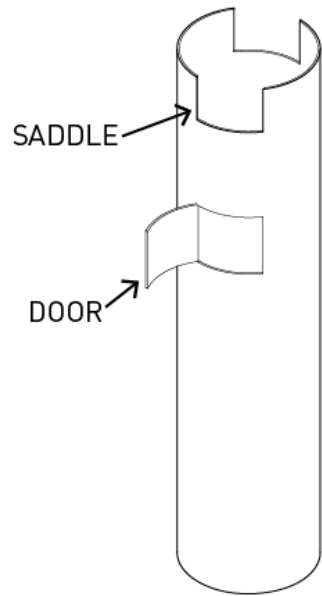

DIAGRAM 12

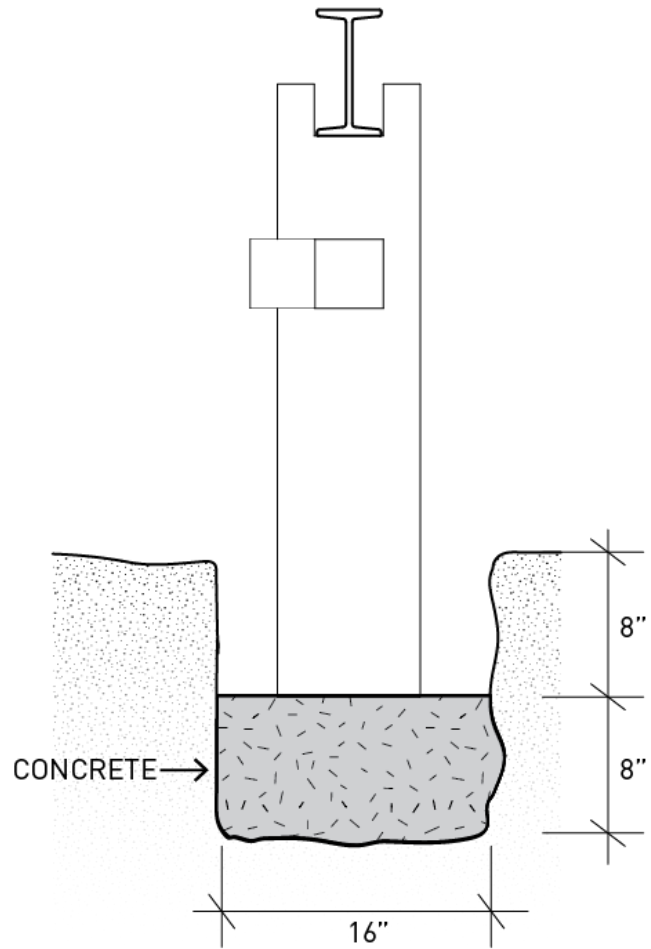

DIAGRAM 13

## **Sonotube Material List**

| <u>Quantity</u> | <u>Item</u>   | <u>Purpose/Notes</u>   |
|-----------------|---------------|--|
| —               | Sonotube(s)   |  |
| —               | Bags sackrete | (3) 60LB bags per hole or (2) 80LB bags per hole<br>AND concrete to fill sonotube:<br>$\pi \times radius^2 \times height = volume$<br>(simple concrete calculators available online to<br>convert volume to # of bags) |
| —               | Duct Tape     | To hold sonotube in place before concrete, and to<br>tape door shut  |
|                 | Scrap Lumber  | To brace sonotube if needed  |

## **Recommended Tools**

### **Safety:**

Glasses

Gloves

Dust Masks

Tyvek Suits (based on conditions under  
home)

### **General Tools:**

Basic Hand Tools (Tape measures, hammer,  
pencils, speed square, etc)

Drop lights/flashlights/head lamps

Extension Cord/Splitter

### **Power Tools:**

Reciprocating Saw

→ Wood Blade

### **Digging/Concrete Tools:**

Shovels (Short handles may be ideal under  
home)

Wheelbarrow or bucket to mix concrete in

Trowels to mix/move concrete in bucket

Garden hoe to mix concrete in wheelbarrow

Hose/Extra bucket for water to mix concrete







# Floors

**Why Floors?** Secure and sturdy floors are important to safety of those living inside and a cleanable finished surface is important to air sealing and air quality in the living space.

## Section Contents:

|                                   |    |
|-----------------------------------|----|
| Floor Structure                   |    |
| Floor Framing                     | 32 |
| Common Joist Repair/Replacement   | 34 |
| Band Joist Repair                 | 37 |
| Additional Floor System Support   | 40 |
| Subfloor Replacement/Repair       | 44 |
| Replacing Full Room Floor System  | 49 |
| Floor Covering                    | 57 |
| (Laminate Flooring & Vinyl Plank) |    |

## Floor Structure

### Safety

- Wear gloves when removing debris/old structures
- Make sure to bend down or remove nails sticking out of any debris lumber
- Wear safety glasses and ear plugs when cutting or working near someone cutting with power saw
- Communicate with homeowner/block off entrance if needed when removing subfloor
- Make sure all loads are supported/kicked while repairs are being made on the floor structure if needed
- Be cautious of any pipes/electric/ducts running underneath the floor system
- Do not jack any part of the home without discussing with staff (or with construction consultant/Home Repair Coordinator)
- Do not use vehicle jacks in place of bottle jacks

## **Floor Project Planning**

### **Framing:**

- Are joists overspanned, do they need additional support?
- Do all joists need to be replaced, could they be repaired?
- Why is there damage? Water/termites/etc. - address those issues as well
- Check the band joist - if there is any rot, what is the source?
- Will subfloor need to be removed? Can repair be made from below?
- Will any temporary support be necessary? (Kickers/Temporary Interior Walls)
- Will any permits/inspections be needed?
- How close will joists be to the ground? If within 18", they should be pressure treated lumber

### **Subfloor:**

- Why is subfloor damaged? Are there other issues that need to be addressed?
- Where will material be stored on site (needs to be kept out of the rain)
- Should insulation be installed before subfloor?
- Is the framing below the subfloor in good condition?
- If subfloor is soft below a window or door be sure to check the band joist
- Will the whole room need to be replaced or just patches?
- Are there vents or any other obstacles to be aware of?
- Are joists level?
- Will any permits/inspections be needed?

| <b>Floor Joist Span Chart (Southern Pine #2)</b> |                                     |                                     |
|--|-------------------------------------|-------------------------------------|
| <b>Joist Size</b>                                | <b>16" On Center - Maximum Span</b> | <b>24" On Center - Maximum Span</b> |
| 2x6  | 9'4"                                | 7'7"                                |
| 2x8  | 11'10"                              | 9'8"                                |
| 2x10   | 14'0"                               | 11'5"                               |
| 2x12   | 16'6"                               | 13'6"                               |

## **Measurements Needed**

- Measure the area of the room/spots to be repaired
- What size material will be needed? (thickness of subfloor and size of joists)
- What size are the current joists? Does that need to be matched?
- What is the spacing of the current joists?

## **Quality Control**

### **Framing:**

- Make sure site is left safe for family overnight
- Make sure joists are level
- Make sure spacing of joists is correct
- Make sure scab extends at least 2' past damaged areas
- Make sure scabs are installed on both sides of joist if possible

### **Subfloor:**

- Make sure that blocking is installed as needed so that there are adequate nailers and all corners of patches are supported
- Make sure OSB is perpendicular to joists
- Start with tongue side to wall
- Stagger seams of OSB
- Make sure short edges of sheets are landing on joists
- Make sure sheet is adequately fastened (every 8" on perimeter and every 12" along interior)
- Make sure seams are tight

## **Common Mistakes**

### **Framing:**

- Joist run from a band or sat on a girder that is not level
- Spacing off so that edges of OSB does not fall on joists
- Scabs too short and not fastened into solid wood

### **Subfloor:**

- Blocking not added around perimeter of room, or under corner of patches, leaving subfloor unsupported
- Tongue to field, more difficult to install following pieces
- Seams lined up, reducing strength of subfloor
- Gaps between pieces of subfloor, tongue and groove not fitted together

## **After Work is Complete Quality Control Check**

### **Framing:**

- Make sure insulation is installed after joist repair, before subfloor
- Are joists adequately fastened/joist hangers used?
- Are joists at an appropriate span?

### **Subfloor:**

- Is subfloor level?
- Are the seams in the subfloor tight
- Does underlayment need to be installed before finished flooring?
- Have holes been cut for all vents/pipes/etc.

# Floor Framing

## Basic Structure:

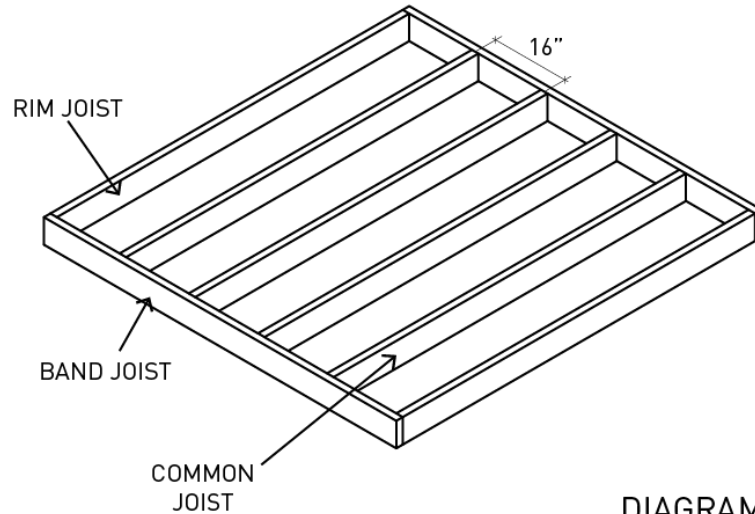

DIAGRAM 1

## Common Joists:

- Common joists are typically spaced every 16" or 24" on center
- Common joists traditionally run perpendicular to the ridge of the roof on home
- Size of common joists depends on length of span, (see span chart on page 28)
- Common joists should be installed at each end with joist hangers or they should be resting on a sill plate or ledger

## Band Joist:

- Runs perpendicular to and intersects common joists
- Typically support a load bearing wall
- There may be a double band joist over pier foundations and a single over continuous foundations (See Diagram 2 and 3)
- This "band" joist may be referred to by other names depending on construction style or region

## Rim Joist:

- The two outside joists of a floor system (perpendicular to band joist)
- Run parallel to the common joists
- Similar to the band, there may be a double rim joist over pier foundation and a single over continuous foundations (See Diagram 2 and 3)
- This "rim" joist may be referred to by other names depending on construction style or region

**Continuous Foundation to floor system connection:**

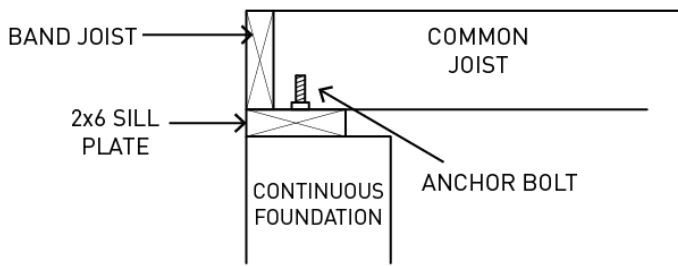

DIAGRAM 2

- When completing repairs on this type of floor system the existing anchor bolts will likely cause issues
  - They may need to be cut off with a metal blade and reciprocating saw
  - Replacement pieces of sill plate should be pressure treated and alternatively connected to the foundation
    - Concrete screws can be used or drop-in concrete anchors depending on the space available to work under the house
    - Look on page 7 in Construction & Tool Basics for installation instructions for concrete screws and anchors

**Pier Foundation to floor system connection:**

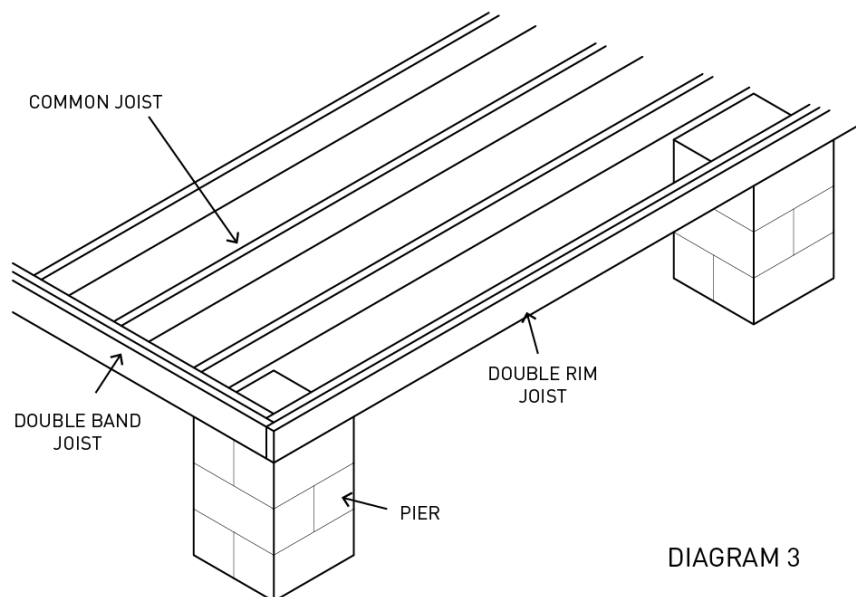

DIAGRAM 3

# Common Joist Repair and Replacement Instructions

When joists need to be replaced, make sure to examine why they are damaged and broken and address those issues as well. Many times when joist(s) are broken a girder will also need to be installed to prevent the same strain on the new members.

Depending on other work to be done on the floor system determine if the work will need to be done from above or below.

Replace or repair? **If there is extensive damage, cracking, or rot to the joist (more than one third) replace the joist rather than repair it.** Otherwise, the joist can be repaired.

## Joist Replacement

- Determine the size of the joist
  - Matching the existing size may be the only option for the available space, but make sure to compare that size to a span chart and add additional support if it is underspanned
- Communicate with the homeowners/other workers to make sure no one is in this area of the house while the repairs are being made
- Cut the replacement joist to length and have ready to install
  - Make sure that the fit will be snug
  - Crown the joist and install with crown facing up (See Diagram 4)
- Remove only one joist at a time (especially if working from underneath)
  - Pull nails/screws holding the joist (See Diagram 5)
  - Use a reciprocating saw with a metal blade to cut any fasteners that may be through the subfloor into the joists
- Put the new joist into place (See Diagram 6)

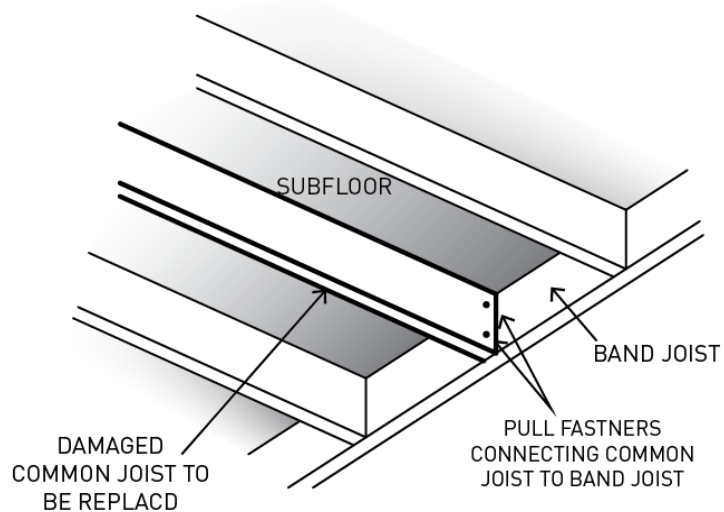
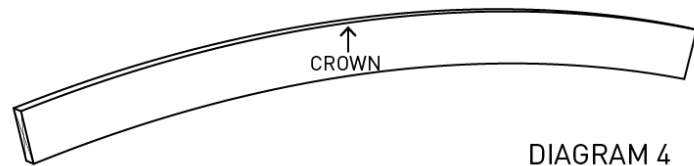

- Set on top of sill plate (if applicable) or hold into place
  - Attach with 12d nails or 2 ½” screws toe-nailed into the band joist
  - If able (if there is no sill plate) add joist hangers to each end of the new joist with joist hanger nails into the flat holes and 2 ½” screws into the diagonals
- Continue across the space, replacing one joist at a time

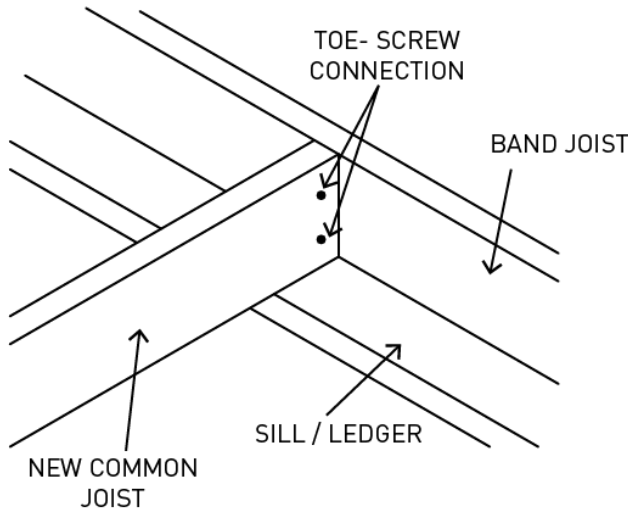

DIAGRAM 6-A

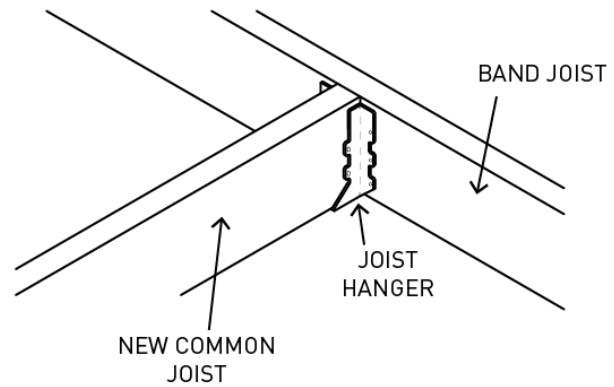

DIAGRAM 6-B

## Joist Repair

- Create a water barrier before fastening any new lumber to rotted areas of existing joists
  - Wrap the old, rotted area of the joist with housewrap/roof felt/ or synthetic underlayment
  - This helps prevent any transfer of existing rot to the new wood
- A “scab” will be installed (ideally) on both sides of the damaged joist (See Diagram 7)
  - Match the size of lumber that will be used for the repairs to the existing joist
  - The pieces of lumber used for the scab should extend **2’ minimum** past the damaged area on either end
- The piece should be cut and installed beside the damaged joist and in contact with the subfloor above
  - If there is a bow in the floor, install the scab as high as possible
  - Attach the scabs to the existing joist using 3” screws or 16d nails
    - Fasten with one screw over the other, every 12” (See Diagram 7)
  - Install scabs on both sides of the damaged joist

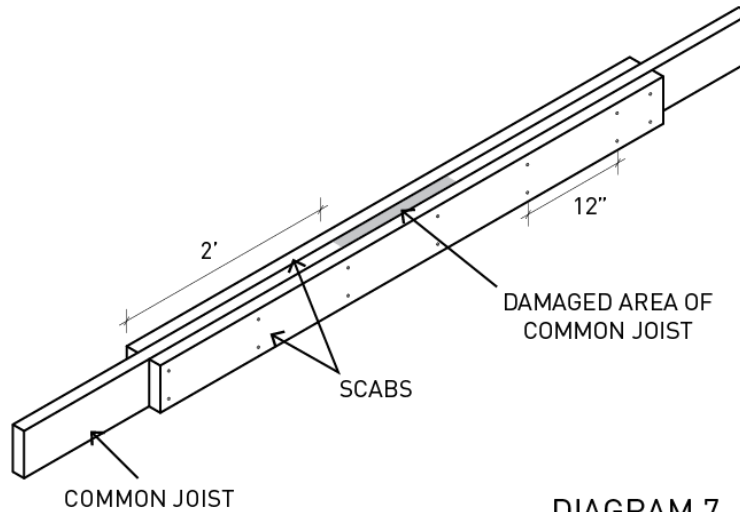

DIAGRAM 7

- If the damaged area is the end of the joist (as common joist connects to the band joist)
  - The repairs will likely occur at the same time as the band joist repairs
  - See additional information on band joist repair below
  - The same method of wrapping the damaged area, and sandwiching the damaged area with scabs will be used
  - The scabs should overlap the good wood of the existing joist twice the length of the damage at the end (See Diagram 8)
    - *For example, if there is a 2' damaged area at the end of the joist, the scab should extend 4' back onto the good wood of the joist. The scabs will be cut to 6'.*
    - The scab should be toe-screwed into the band joist

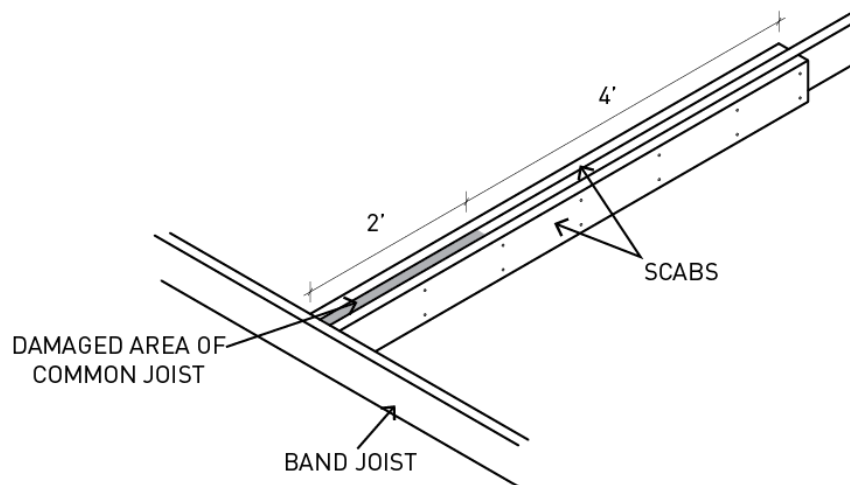

DIAGRAM 8



## Band Joist Repair

When completing band joist repair, the weight of the wall and roof will need to be temporarily supported before the needed repairs can be made. This will be done by using kickers. The common joists of the floor system will also need to be held into place temporarily, as they are usually held by the band joist.

- To install kickers:
  - Install a 2x4 ledger on the outside of the home/siding, close to the top of the wall (See Diagram 9)
    - Remove siding to prevent damage if possible
    - Attach with 16d nails or 3" screws
    - **Make sure 2x4 ledger is fastened into the studs**
  - Install 2x4 Kickers (See Diagram 9 and 10)
    - These fit snug under the ledger and run diagonally down from the ledger to the ground at a 4' down, 1' out ratio
    - Where the kicker meets the ground it should be attached to a 2x4 stake that is driven into the ground 24"
    - Attach kickers to stake with 3" screws
    - A kicker should be placed at each end and every 6' along the walls where the floor is to be repaired
      - If work will take over 2-3 days, install kickers every 4'

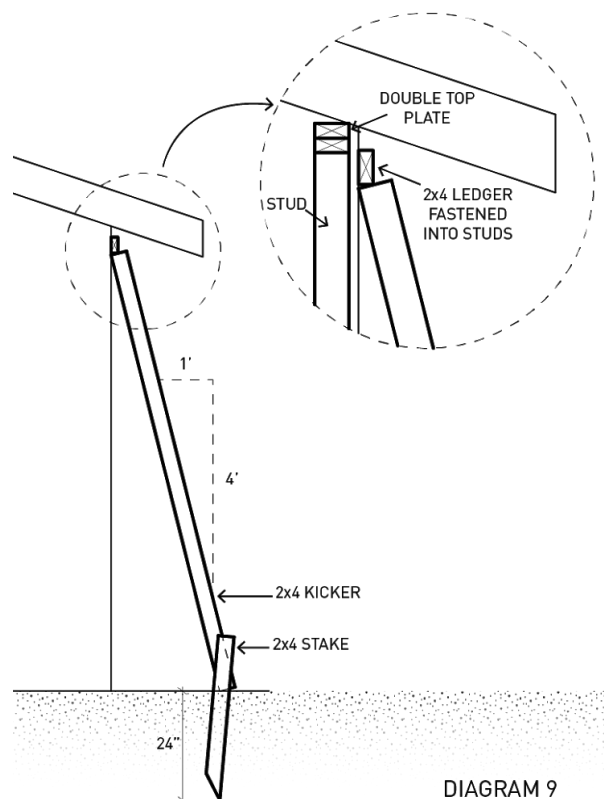

DIAGRAM 9

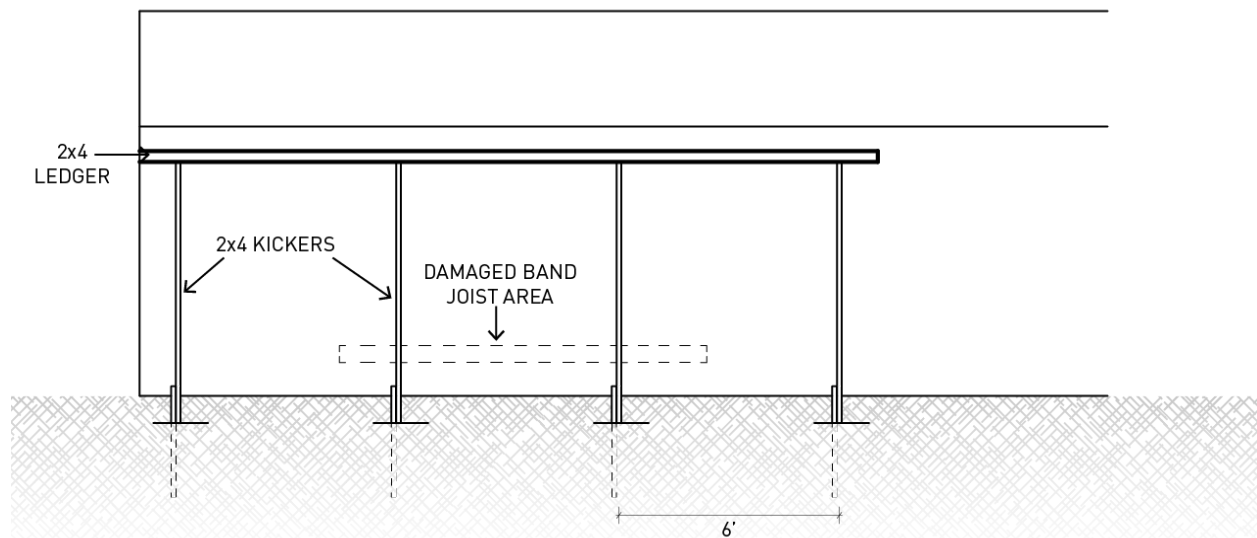

DIAGRAM 10

- The common joists of the floor system will also need to be temporarily held in place while the band joist is repaired (See Diagram 11)
  - This is done by running a 4x4 underneath and perpendicular to the common joists 1'-2' back from where the band joist repair will occur
  - Support the 4x4 with bottle jacks (with minimal pressure applied)
    - Bottle jacks in this situation are being used to hold, not lift the floor system
    - Set the bottle jacks on a concrete block
      - Level the ground underneath the block if needed
      - If the common joists are far from the ground, you may stack 2-3 concrete block to sit the jack on, just make sure the ground is flat and the stack is very stable

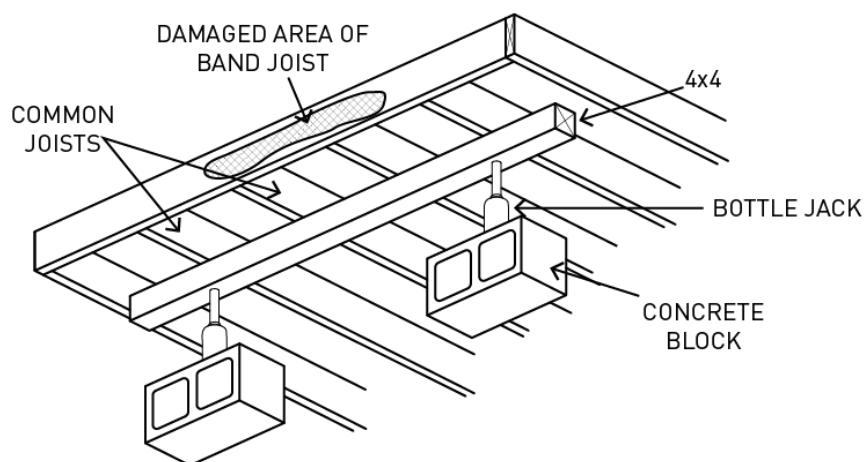

DIAGRAM 11

- Once the weight of the wall/roof and the joists are all temporarily supported, sections of the band joist can be removed and replaced
- Repairing the band joist (See Diagram 12)
  - Always use pressure treated lumber
  - Match the size of the new lumber to the existing
  - Remove damaged sections
    - A maximum of 8' of band joist should be removed and repaired at one time
    - The minimum section to be removed should be 4'
    - Plan that the ends of new sections of band joist fall onto common joists so that there is something to attach them to
    - Cuts can be made into the existing band joist to control how much is taken out at once
      - Set the depth to 1 ½" on a circular saw to cut band joist
    - Sometimes the band joist may have so much damage it does not need to be cut, but can be pulled away gently
    - When removing sections, pry gently
      - Try removing fasteners through the band joist so the piece can be lifted out of place
  - Install new section
    - When new sections of band joist are installed, the ends should fall on common joists
    - Cut replacement piece to length (whether that is a full 8' section or a smaller section)
    - Attach new section of band joist with 3" exterior screws or galvanized 16d nails through the new band joist into the ends of common joists
    - If applicable, continue working down the band joist, removing and replacing 8' sections
    - At each end of all new sections, install a metal connection plate, attached with joist hanger nails (See left side of Diagram 12)

- Once the necessary repairs to the band joist are completed, the temporary support underneath the joists and the kickers can be removed

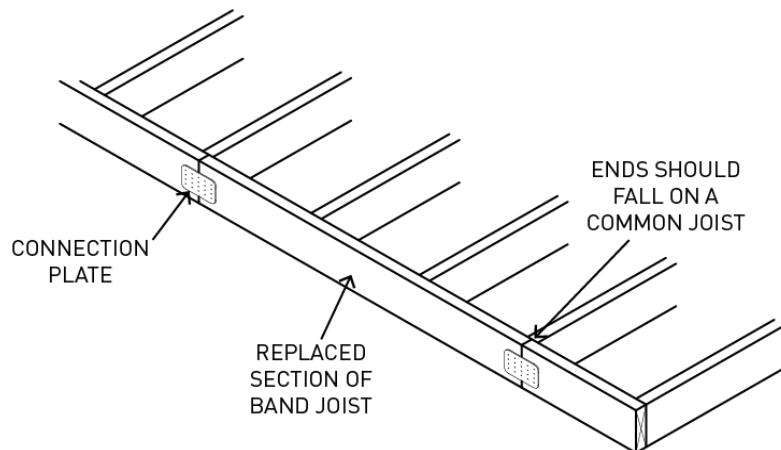

DIAGRAM 12

# Additional Floor System Support

## Blocking

Blocking in a floor system is simply additional support blocks in the floor system that run perpendicular to the common joists. (See Diagram 13 - "Blocking" is any individual piece of the illustrated "bridging")

Blocking is useful:

- Around the edges of openings when replacing sections of subfloor
- Underneath toilets, water heaters, and the long edges of tubs
- Under the edges of cabinets
- In high traffic door ways

Blocking pieces should be the same size as the common joists and installed with 3" screws or galvanized 16d nails. Make sure blocks are flush with the tops of the joists.

## Bridging

Bridging is a system of blocks installed between joists in a floor system (See Diagram 13). Bridging should be considered when there is some movement in a floor system where the joists are not overspanned. (If joists are overspanned, a girder should be used rather than bridging). Bridging can be installed in addition to girders, but not instead of.

Bridging is a good option when a larger size joist is used (2x10 or bigger) to prevent twisting.

- Installing bridging:
  - Blocks used in bridging should be the same size as the joists.
  - Pieces of bridging should be staggered and face screwed through the common joists into the ends of the bridge pieces
  - Make sure tops of pieces are level with tops of the joists
  - Install pieces using 3" screws or galvanized 16d nails
  - This is an easier support method when floor system can be accessed from the top

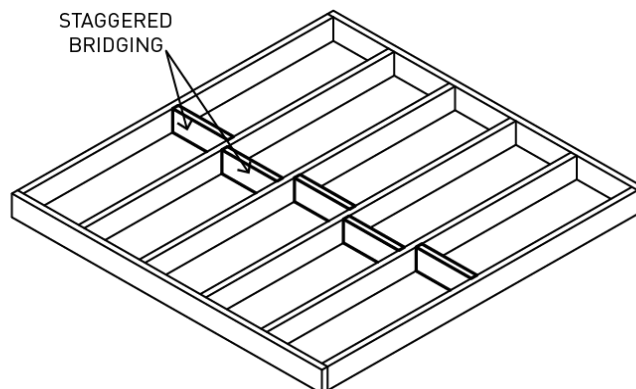
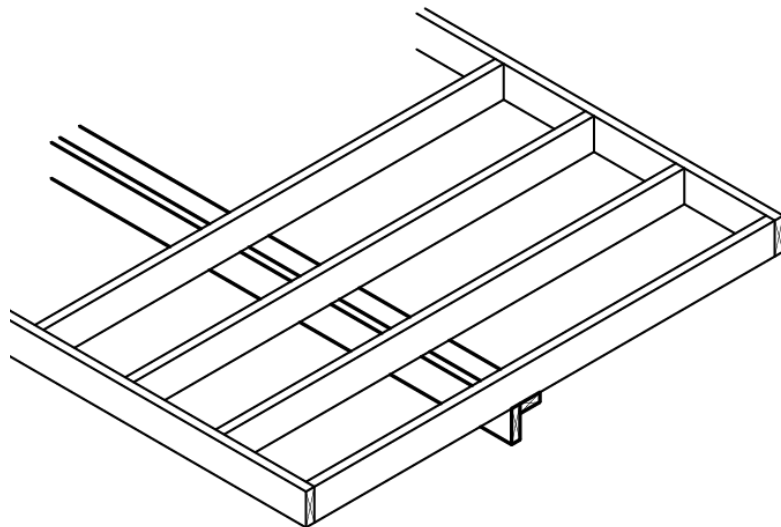
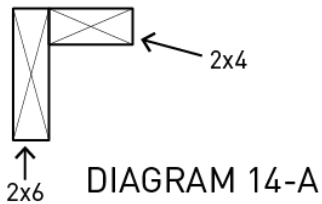

DIAGRAM 13

## **Stiff-Backs**

Stiff-back can be installed as an additional support to floor systems that have some movement in them, but where the joists are not overspanned (If joists are overspanned, a girder should be used rather than stiff backs). If the floor simply bounces a little bit, a stiff-back is a good choice.

- Build stiff-back
  - A 2x4 and 2x6 will be put together in an “L” shape (See Diagram 14A)
    - Attach with 3” screws or galvanized 16d nails
- Install perpendicular to the floor joists with the 2x4 side touching the joists (See Diagram 14B)
  - Attach with 3” screws or galvanized 16d nails, face screwed into the bottom of the joist
- Place the stiff-back through the middle of the floor system
- If multiple stiff-backs are being installed, space them evenly underneath the floor system
- This is an easier support method when floor systems can only be accessed from underneath



## **Joist Repair/Replacement Materials**

| <b><u>Quantity</u></b> | <b><u>Item</u></b>                        | <b><u>Purpose/Notes</u></b>  |
|------------------------|---|--|
| ___                    | 2x___x___                                 | Scabs or replacement joist. PT if within 18" of ground                         |
| ___                    | Vapor Barrier                             | Housewrap/tar paper to wrap water damaged joist                                |
| ___                    | 3" Deck Screws or<br>Galvanized 16d Nails | To attach the scabs or install the new joist                                   |
| ___                    | Joist Hangers                             |  |
| ___                    | Joist Hanger Nails                        | If applicable to installing the new joist, coordinate to the size of the joist |

## **Recommended Tools**

### **Safety:**

Glasses  
Gloves  
Ear Plugs  
Dust Masks

### **General:**

Basic Hand Tools (Tape measures, hammer, pencils, speed square, etc)  
Cats claw/nail pullers  
Pry Bars  
Extension Cords/Splitters  
Utility Knife  
Drop Lights or Flashlights

### **Power Tools:**

Circular Saw or Miter Saw - to cut new joist pieces to length  
Drill or Impact Driver  
→ T-25 Drivers for Deck Screws  
Reciprocating Saw with metal blade - to cut off any interfering nails from subfloor  
→ Metal Blade  
→ Demo Blade

## **Band Joist Repair Materials**

| <b><u>Quantity</u></b> | <b><u>Item</u></b>          | <b><u>Purpose/Notes</u></b>                             |
|------------------------|-----------------------------|---|
| ___                    | 2x__x__ PT                  | Matched to the size of the existing band joist          |
| ___                    | 2x4x__ White Wood           | 2x4 ledger, kickers, stakes                             |
| ___                    | 4x4x__ PT                   | For temporary supports under the common joists          |
| ___                    | Concrete Blocks             | For temporary supports under the common joists          |
| ___                    | Connection Plates           | To attach ends of new sections of band joist            |
| ___                    | Joist Hanger Nails          | For attaching connection plates                         |
|                        | 3" Deck Screws or 16d nails | For attaching new pieces of band joist to common joists |

## **Recommended Tools**

### **Safety:**

Glasses  
Earplugs  
Dust Masks  
Gloves

### **General Tools:**

Basic Hand Tools (Tape measures, hammer, pencils, speed square, etc)  
Bottle jacks  
Sledge Hammer - to drive stakes into the ground  
Pry Bars  
Extension Cords/Splitters  
Cats Claw/Nail Puller

### **Power Tools:**

Circular Saw  
Drill/Impact Driver  
→ T-25 Driver for Deck Screws  
Reciprocating Saw  
→ Demo Blade

# Subfloor Replacement and Repair

In mobile homes, the subfloor is typically a compressed particle board and in some older houses the flooring will be 1x6 planks. Otherwise subfloor is generally 3/4" OSB or 3/4" plywood.

The material that will be used in subfloor replacement will be 4'x8' sheets of 3/4" tongue and groove OSB.

## Full Room Subfloor Replacement

- Remove existing subfloor
  - To easily remove subfloor that has been glued to common joists:
    - Make cuts with a circular saw in the middle of the bays between the joists and rock the cut strip of flooring back and forth over the joist so that the staples can work loose and it will ideally come out in a large pieces (See Diagram 15)
      - Look at the nailing pattern to see where the joists are
      - Simply trying to pry up the particle board, it will most likely just crumble into small pieces, leaving glued chunks on top of the joists
    - Clean off the remaining chunks on top of the joists (a hammer and chisel work well for this)
  - If subfloor is not glued to the joists:
    - Pry pieces up carefully, bending down nails/staples as pieces are removed

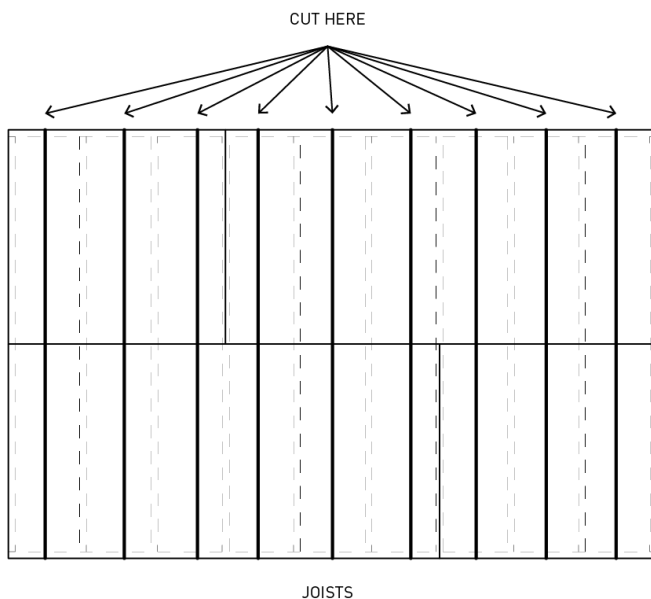
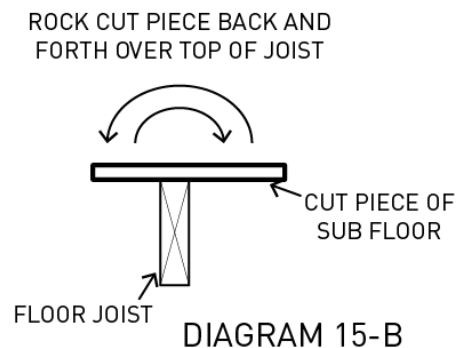

DIAGRAM 15-A





- Install any needed nailers or blocking
  - If there is any instance where the short edge of a sheet of OSB would not land on a joist, install nailers between joists so that the OSB will have a bearing surface to rest on
  - Blocking will most likely be needed where a wall runs parallel to the common joists (See Diagram 16)

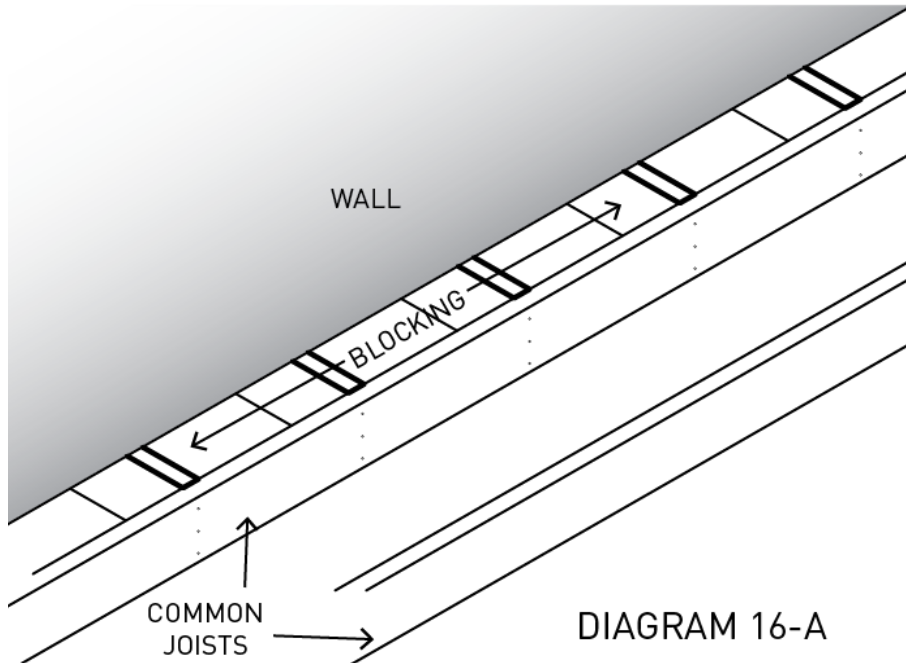

DIAGRAM 16-A

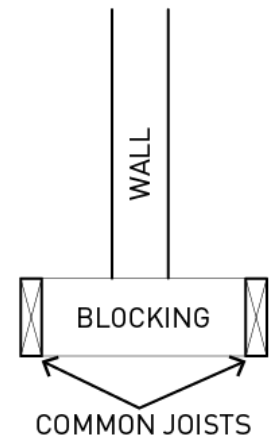

DIAGRAM 16-B

- Double check that all floor structure is in good shape before installing subfloor
- Plan layout of OSB
  - If possible, each sheet should cover at least 2 bays and 3 common joists
  - It is best to avoid using small pieces of OSB because there is greater strength with fewer seams
  - Seams should be staggered by at least 2 joist widths
- Install OSB (See Diagram 17)
  - Apply a bead of construction adhesive to the top of each joist before installing the OSB
    - Only do this after dry-fitting the pieces
  - OSB will run perpendicular to the common joists
  - Each 4' edge of the OSB should always land on a floor joist
  - Start with the tongue side of the OSB against the wall
  - Attach the OSB with 2" screws or 8d ring shank nails every 12"

- For the second row of OSB:
  - Stagger the short seams by at least 2 joist widths
  - Interlock the tongue and groove (See Diagram 18)
    - **Do not hit the groove side with a hammer to tap into place**, this will damage the groove. Use a scrap piece of OSB with the tongue still attached and place it into the groove and hammer on that scrap instead (See Diagram 19)
    - The gap between the surface of the two pieces of OSB should be  $\frac{1}{8}$ " maximum

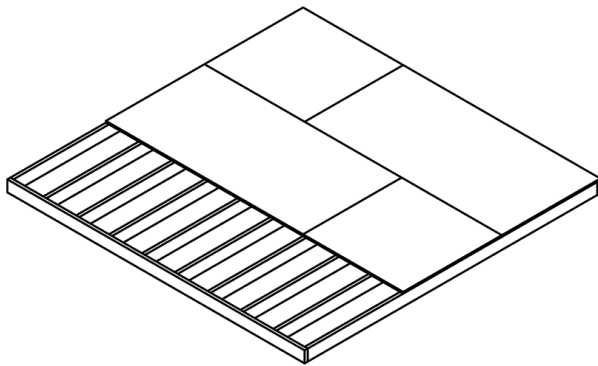

DIAGRAM 17



DIAGRAM 18

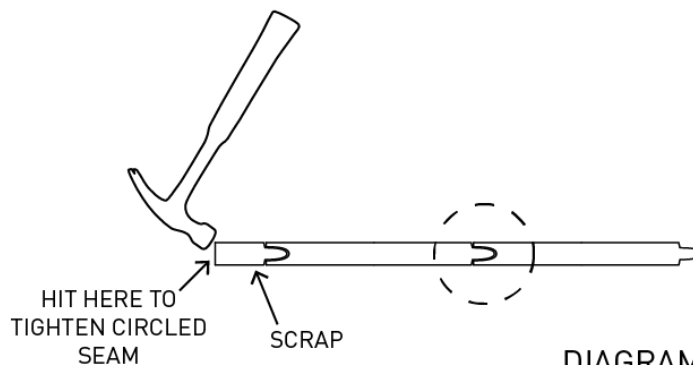

DIAGRAM 19

- As needed, cut out holes for vents, toilets, etc. with a jigsaw, start the cut by drilling a large hole in the middle of the planned cut.
  - If helpful, use cardboard or some other scrap to make a template around these difficult cuts
- Continue installing OSB in rows and following the same process until a full row will no longer fit
  - For the last row, cut the OSB to width with the tongue side remaining so that the pieces will still interlock

## Sections of Subfloor Repair

While subfloor damage can happen anywhere in a home, common areas that need subfloor repair are around toilets, directly inside exterior doors, under/in front of kitchen sinks, and below windows.

In an effort to create solid patches with fewer seams, the minimum area that should be replaced at any time is equivalent to half sheet of OSB.

- Mark the area to be removed
  - Look at the fasteners through the subfloor to identify where the joists are
  - Use a framing square to make marks square and a chalk line to transfer the lines
  - Plan the replacement piece so that the two “short” edges will fall on top of floor joists
- Set the depth of a circular saw to  $\frac{3}{4}$ " and plunge cut into the subfloor to cut out the damaged piece
  - Pull nails that will interfere with the cut before cutting to preserve the saw blade
- If the repair is in a high traffic area, add nailers between the joists to catch the edges of replacement piece and provide additional support (See Diagram 20)
  - Nailers/blocking should be the same size as the joists and be installed with 3" screws, make sure the top of these nailers is level with the tops of the joists
- Cut the replacement piece of OSB to size
  - If necessary, cut the tongue off of the new piece
  - Dry-fit the new piece to make sure it fits in the space well
  - Add a bead of construction adhesive to the tops of the floor joists
  - Attach the piece of OSB with 2" screws or 8d ring shank nails every 12"

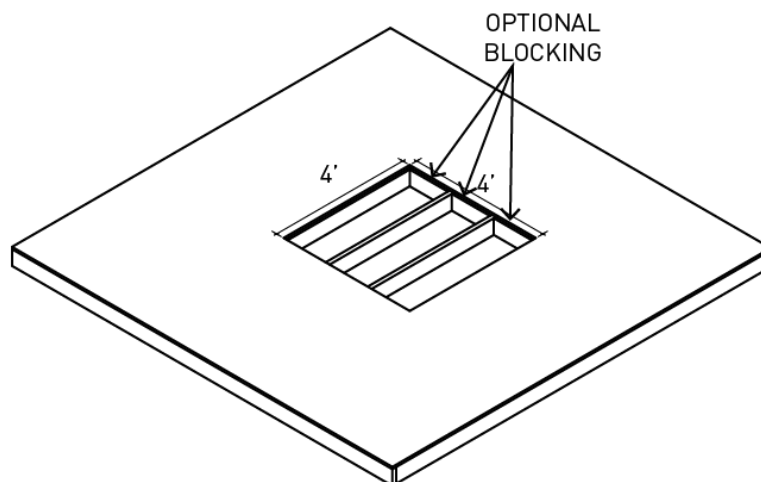

DIAGRAM 20

## **Subfloor Materials**

|     |   |   |
|-----|---|---|
| ___ | 3/4" OSB                                  | <i>Sq Ft of room or area/32 SF(size of one piece) = # of pieces</i> |
| ___ | 2x__x__                                   | Blocking/Nailers. PT if within 18" of ground                        |
|     | Construction Adhesive                     | To glue OSB to top of joists  |
|     | 2 1/2" Deck Screws/8d Nails               | Attaching OSB to joists   |
|     | 3" Deck Screws or<br>galvanized 16d nails | For blocking/nailers  |

## **Recommended Tools**

### **Safety:**

Gloves  
Glasses  
Ear Plugs  
Dust Masks

### **General:**

Basic Hand Tools (Tape measures, hammer, pencils, speed square, etc)  
Chalk Line  
Framing Square  
Chisels - For cleaning off top of joists  
Pry Bars  
Caulk Gun  
Extension Cords/Splitters

### **Power Tools:**

Circular Saw  
Drill/Impact Driver  
→ T-25 Drivers for Deck Screws  
→ Large drill bit to start holes for jig saw  
Jig Saw - for cutting notches around vents/etc.  
→ Wood Blade  
Reciprocating Saw  
→ Demo Blade  
→ Wood Blade

# Replacing a full room floor system

There will be occasions where the entire floor system of a room (subfloor, joists, foundation, etc.) needs to be replaced. An important consideration for this type of repair is to make sure that the weight of the walls and roof are supported by something temporarily while the work is completed and permanently after the work is finished. **Every situation will be different, work with construction consultant or HRC to determine most appropriate plan.**

Typically the load bearing walls of a home run parallel to the ridge of the roof and the first step will be to adequately support those load bearing walls.

If possible, the ideal way to support load bearing walls is to build girders underneath the load bearing walls. See instructions for building girders in the “Girder” section of the manual.

- For **exterior** walls, the wall will likely have to be supported with kickers during this process to temporarily remove the weight of the wall and roof while the girder is installed
  - See instructions for installing kickers on page 32
- For **interior** walls, there will have to be temporary supports to hold the weight of the roof while the girder is installed
  - A brace will serve as temporary support for the roof/wall for interior load bearing walls: (See Diagram 21)
    - A double 2x6 will be supported by 4x4 posts sitting on concrete blocks on leveled earth
      - Assemble with 2 ½” screws or 12d nails
      - Double 2x6 should run parallel to the wall, about 1'-2' from the wall
      - 4x4 posts should be installed every 6', measured and cut snug between the double 2x6 and the concrete block

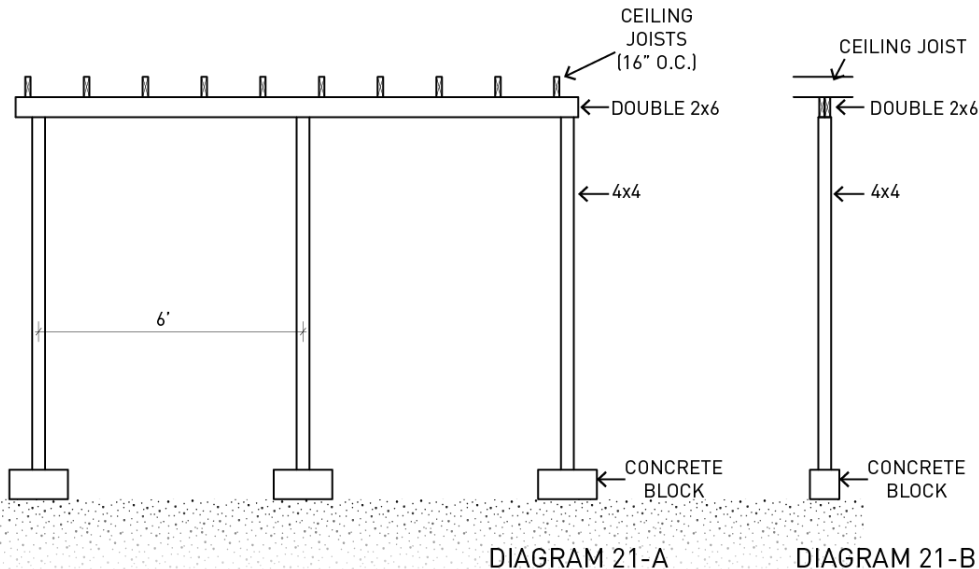

- **Once all loads are accounted for, repairs can start to be made on the floor system**

**Girders may be built to support walls previously supported by the floor system to be replaced.**

Underneath exterior load bearing walls where the full floor system is being replaced, a girder should be built to support that load bearing wall (See Diagram 22)

- See instructions for building girders on page 17
- The girder should fit snug underneath the base plate of the wall (rather than under common joists), and between piers
- This girder will also act as the band joist for the floor system later when the common joists are installed

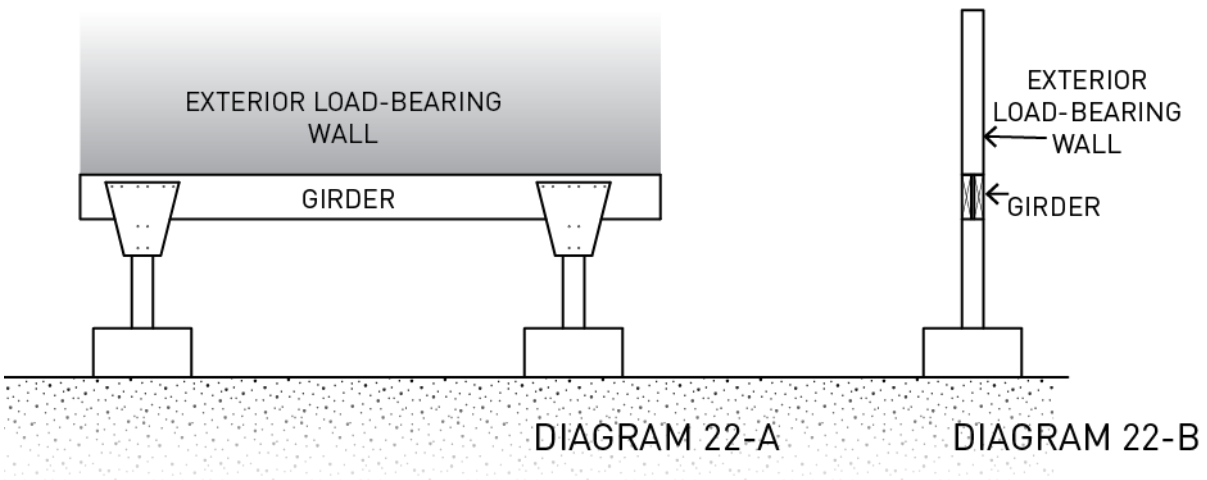

- Joists coming in from another room (on the other side of an interior load bearing wall) may cause interference with building a girder to support this interior wall
  - If the joists are in good condition below this interior wall (See Diagram 23):
    - There can be a girder built underneath these joists
      - See instructions for building girders on page 17
      - Existing joists can be left extending several feet into the room where the floor repairs are being made so that the old and new joists can be sistered together over the new girder (See Diagram 24)

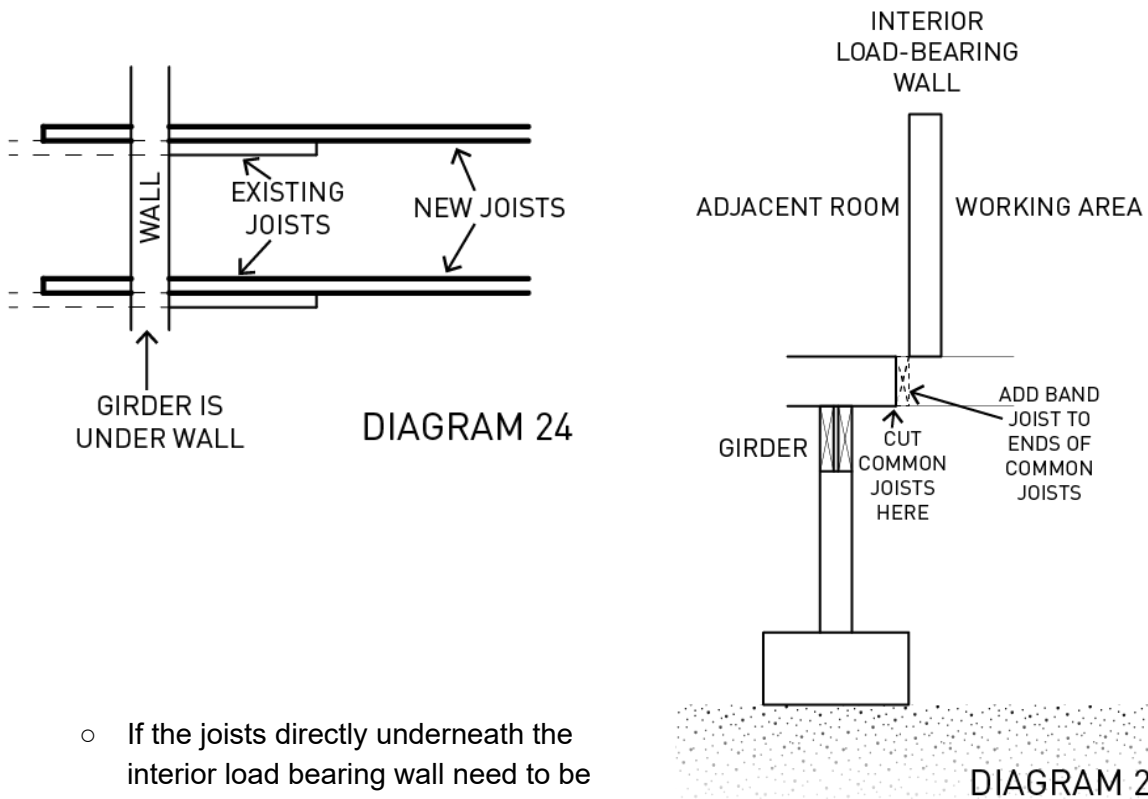
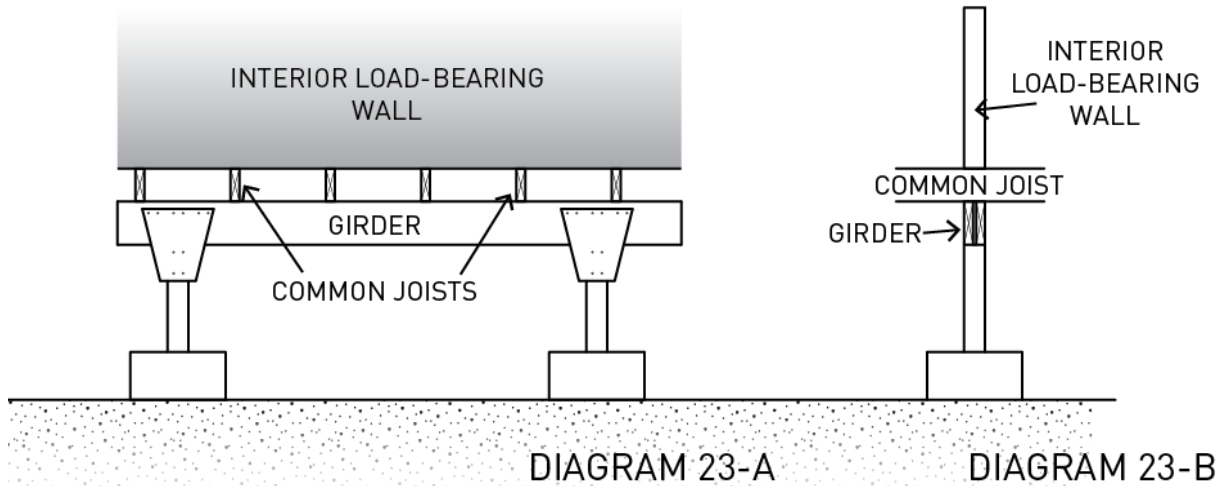

- If the joists directly underneath the interior load bearing wall need to be replaced: (See Diagram 25)
  - A girder will need to be added underneath the floor system in the adjacent room to hold the joists
    - See instructions for building girders on page 17
  - Common joists should be cut and a band joist should also be added to the end of these joists to tie the floor system of that room together
  - **Make sure temporary support for interior load bearing wall is in place before cutting joists**

- After the girder is installed and the adjacent floor system is supported, the existing floor structure in the working area can be removed
- A girder should be built underneath the interior load bearing wall (See Diagram 22 - the girder will be in the same location except the wall will be an interior wall)
  - The girder should fit snug underneath the base plate of the wall (rather than under common joists)
  - This girder will also act as the band joist for the floor system later when the common joists are installed
- Diagram 26 shows two options for how the new floor system could work, depending on the conditions of the joists in the adjacent room

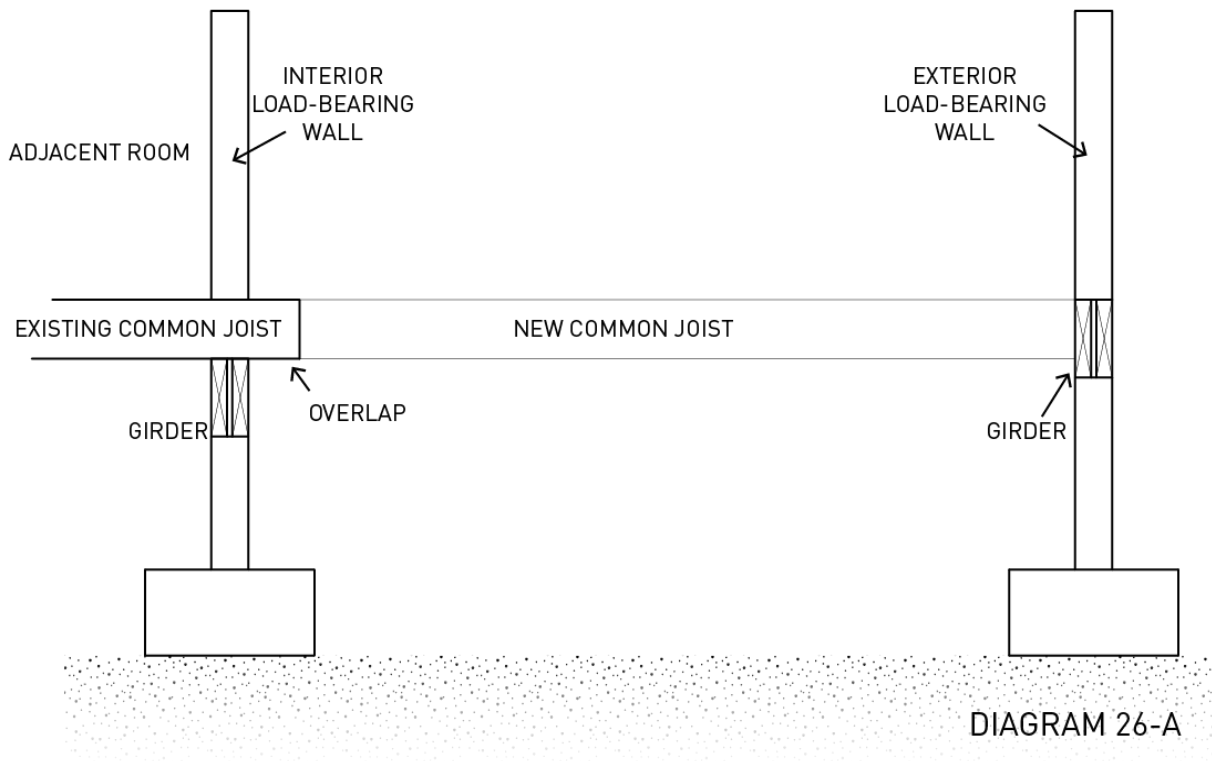



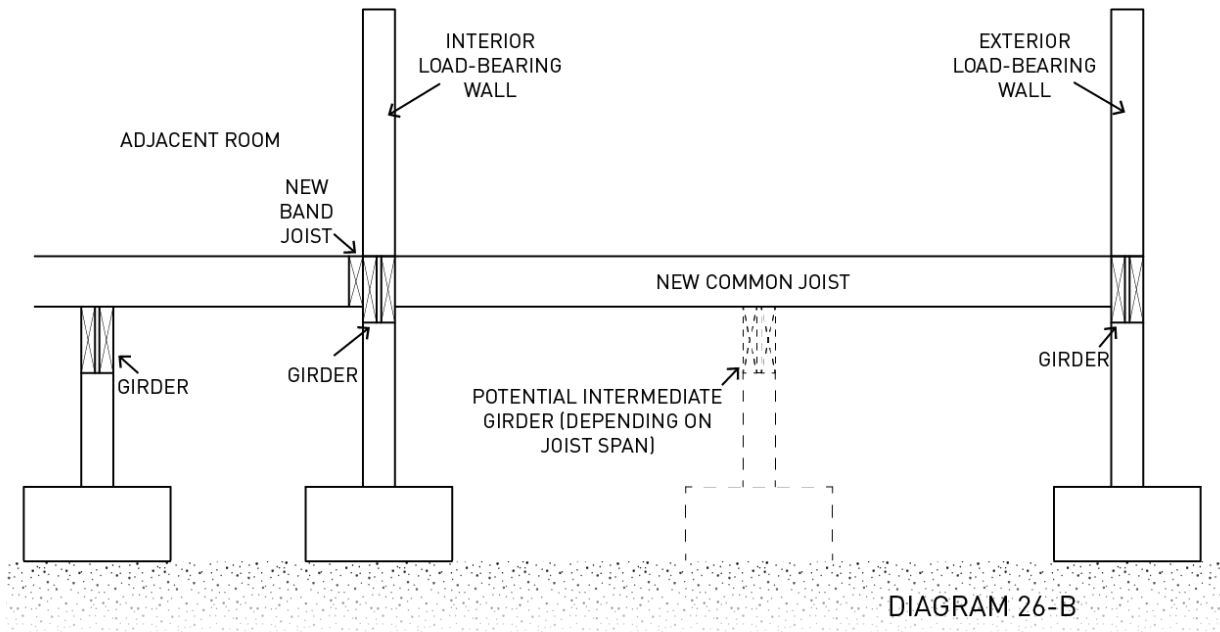

- Once the girders are installed underneath the load bearing walls, all kickers and temporary supports can be removed
- Girders installed underneath walls are not necessarily going to be level, because the walls are likely not level if the floor system is sagging
  - The control point for the level of the floor will most likely be the door to the room
    - At the door, measure down the thickness of the finished floor and the subfloor added together (if applicable) this will indicate the tops of the common joists
      - Transfer this line across the girder/band joist with a long level
    - Transfer the level across the room using a string level and make a mark for the top of the joists on this side of the room as well
- If there is a dramatic slope in the girder, a wide substitute band joist (like a 2x8 or 2x10) can be attached to the girder level (See Diagram 27)
  - Attach with ledger loks one over the other, every 24"
  - If this substitute band board is used on either side, common joists will connect to it rather than directly to the girder

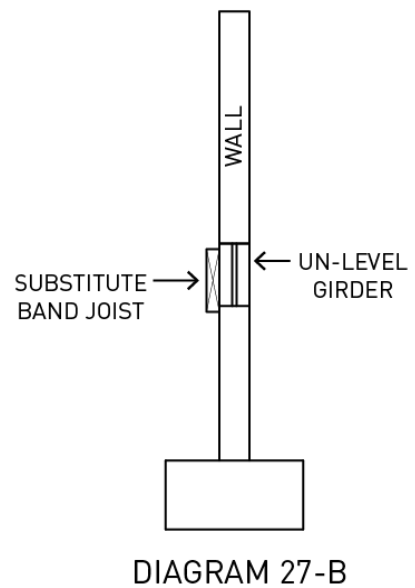
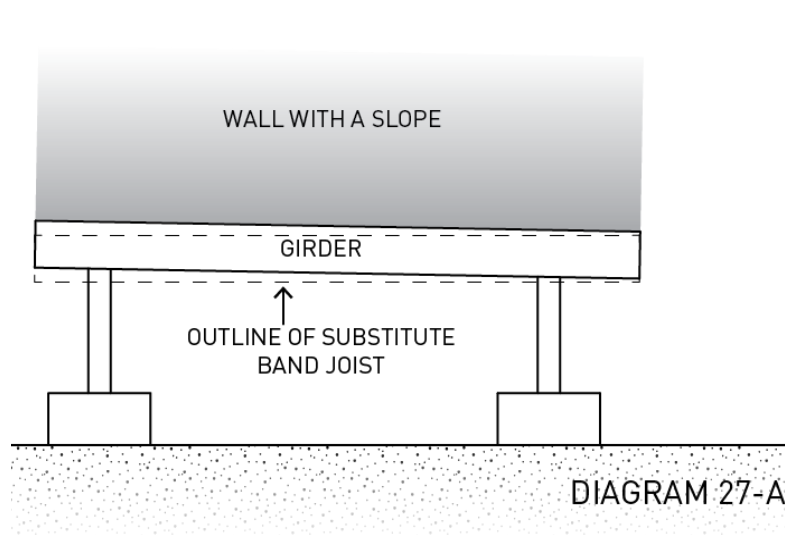

### **New Joists can now be installed**

- Determine the size of the joist to be used, based on span chart and any additional girders that will be installed
- Make sure that new joists are installed level
- Install every 16" on center
- The girder (or substitute band joist) will act at the band joist and common joists will connect directly to it using joist hangers coordinating to the size of joists
  - Use joist hanger nails through the flat surfaces and 2 ½" screws or 16d nails through the diagonals
- Make sure that a joist is installed underneath non-load bearing walls or that blocking is included to support those walls (See Diagram 16)
- Intermediate girder(s) can be used to support the new common joists as needed (See Diagram 26B)
  - See instructions for building girders on page 17
  - If using intermediate girders one common joist can be installed near each end of the room and then girders can be built up to the bottom of them (rather than trying to figure out what height to build the girder)
    - This way the girder can be installed with less common joists as obstacles
  - Make sure that the girders extend underneath the non-load bearing walls so that the floor system will provide support for them
  - After the girder is installed, the remainder of the common joists can be installed

Subfloor, finished floor, and trim can then be installed

## Full Floor System Replacement Materials

| <u>Quantity</u>  | <u>Item</u>                              | <u>Purpose/Notes</u>                                |
|--|--|---|
| <b>Girder Materials - See Girder Section for materials and tools</b> |  |   |
| ___  | 2x4x__ White Wood                        | Ledger, kickers, stakes                             |
| ___  | 2x6x__ White Wood                        | Temporary bracing for interior load bearing walls   |
| ___  | 4x4x__ PT                                | Temporary bracing for interior load bearing walls   |
| ___  | Concrete Blocks                          | Temporary bracing for interior walls                |
| ___  | 2x__x__ PT Substitute Band               | If applicable because of slope in the wall          |
| ___  | Ledger Loks                              | If applicable, to attach substitute band            |
| ___  | 2x__x__                                  | joists and rim joists . PT if within 18" of ground. |
| ___  | 2x__x__                                  | Any necessary blocking/nailers                      |
| ___  | 3/4" OSB                                 | Subfloor  |
| ___  | Joist Hangers                            |   |
| ___  | Joist Hanger Nails                       |   |
|  | Construction Adhesive                    | To glue subfloor to joists                          |
|  | 3" Deck Screws                           | To connect framing members                          |
|  | 2" Deck Screws or<br>8d Ring Shank Nails | To attach subfloor to joists                        |
|  | Shims                                    |   |

## Recommended Tools

### Safety:

Gloves  
Glasses  
Ear Plugs  
Dust Masks

### General:

Basic Hand Tools (Tape measures, hammer, pencils, speed square, etc)  
Chalk Line  
Framing Square  
Chisels - For cleaning off top of joists  
Pry Bars  
Caulk Gun  
Extension Cords/Splitters  
Saw Horses  
String/String Level

### Power Tools:

Circular Saw  
Miter Saw  
Reciprocating Saw  
→ Demo Blades  
Drill/Impact Driver  
→ T-25 Driver for Deck Screws  
→ 5/16" Hex Driver or T-40 Driver  
(coordinating to ledger loks)  
→ Wide bit for starting jig saw notches  
Jig Saw - for cutting notches around vents/etc.  
→ Wood Blade

# Floor Coverings

## Floor Covering Project Planning

- Make sure flooring material sits in home and acclimates to temperature for 48 hours
- Is the subfloor level? Will you need underlayment?
- What wall of the room will the laminate start on? (parallel to long side of room)
- Are there any vents/obstacles in the floor to be aware of?
- Make sure laminate installation kits are available
- If using laminate, communicate with homeowner that product cannot be wet mopped, make sure they understand and are okay with how the floor needs to be maintained

## Measurements Needed

- Measure the area of floor
- Measure the perimeter of the room for baseboard
- Order an extra 10% for waste and mistakes
- Quantity and length of transition strips

## Quality Control

- Make sure foam underpad is installed before **laminate** if needed
- Make sure spacers are used around the perimeter of the flooring so that it has room to expand and contract
- Make sure the flooring runs parallel to the long side of the room
- On the first row put tongue against the wall and groove facing out (laminate) or that the sticky tab faces the field (vinyl plank)
- Make sure there are no gaps or spaces between pieces of flooring
- Make sure seams are staggered by at least 12"
- Make sure cut pieces of laminate are no smaller than 12"

## Common Mistakes

- Flooring butted up to wall, which can cause buckling later
- Flooring rotated 180°, making installation difficult
- Spaces/cracks left between pieces of flooring allowing edges to chip and dirt to gather, for vinyl plank this reduces water tightness
- Not planning out rows so that pieces are both long enough and seams are staggered 12"

## After Work is Complete Quality Control Check

- Remove spacers
- Install baseboard and transition strips to protect edges of floating floor system
- Remind homeowners no wet mopping (for laminate)
- Are all seams of flooring tight?

## Flooring Underlayment

Flooring underlayment is installed over subfloor, before finished flooring to help provide a smooth surface or cover any gaps left from subfloor patches.

Clean area well before installing underlayment.

### Lauan Underlayment:

- Lauan is a ¼" plywood that comes in 4'x8' sheets
- Lauan should be installed perpendicular to the subfloor
- Seams of lauan should not line up with seams of the subflooring
- Seams of the lauan should be staggered by 2'
- Fasten lauan with drywall screws and a dimpler bit every 6" around the edges and every 12" in the field
- Seams should be tight and there should not be any gaps

### Foam Underlayment:

- Used as a moisture barrier and acoustical dampener and slight insulation barrier in some laminate installations
- Can come in rolls or fan fold
- Important to stick courses of underlayment together to provide moisture barrier
- Only use underlayments that are recommended by flooring manufacturers

## Vinyl Plank and Laminate Floor Covering

### Laminate Floor Covering - Basic Information

- Suitable for areas with little moisture (**not** kitchens/bathrooms)
- Subfloor surface must be very flat
- Must be allowed 48 hours to acclimate to the room temperature before installation
- Requires laminate installation kit for install
- Some products will have a foam underpad attached to the back of each piece. If this is not present, a separate foam underpad must be installed
  - Rolls of underpad typically have a designated tab for the overlap (otherwise pieces can be taped together)
  - Cover the entire area of the floor where laminate will be installed
- Pieces are cut with a laminate saw or miter saw with a finishing blade
- If installing flooring on a concrete subfloor, a 6mm moisture barrier should be laid (seams should be taped and barrier should be run 6" up the wall)

## Vinyl Plank Flooring Covering - Basic Information

- Water resistant flooring (good for kitchens/bathrooms/laundry)
- This material is flexible enough to be used on surfaces that are not completely flat
- Must be allowed 48 hours to acclimate to the room temperature before installation
- Pieces are cut by scoring with a utility knife and bending to break
- If there are any gaps in the subfloor greater than 1/4", they need to be filled with floor leveling compound before flooring is installed
- If installing flooring on a concrete subfloor, a 6mm moisture barrier should be laid (seams should be taped and barrier should be run 6" up the wall)
- Vacuum/sweep before and during installation, particles that get on the sticky tab will keep it from adhering well

## Laminate and Vinyl Plank Installation Instructions

- Determine the layout of the flooring in the room
  - Typically laminate and plank style flooring are installed parallel to the long wall of the room
  - The shortest piece that should be used is 12"
    - Make sure that each row is started with a size piece that will allow the last piece in the row to also meet the 12" minimum
    - *For example, if the pieces of laminate are 3' and the length of a room is 12' 6"...*
      - **Do:** *Cut at least 6" off of the first piece in the row so that the last piece will meet the 12" minimum*
      - **Do not:** *install four full length pieces and then one 6" piece*
      - *Be cautious of which edge you trim so that the pieces still have the correct locking edge*
  - Seams of each row will be staggered by at least 12" (See Diagram 28)
    - So long as it works with the 12" minimum length for pieces at the end of the row, start the first row with a full piece, the second row with 2/3 of a piece, and the third row with 1/3 of a piece and then repeat this pattern
    - If this pattern does not work with the length of the room, find a staggering pattern that does

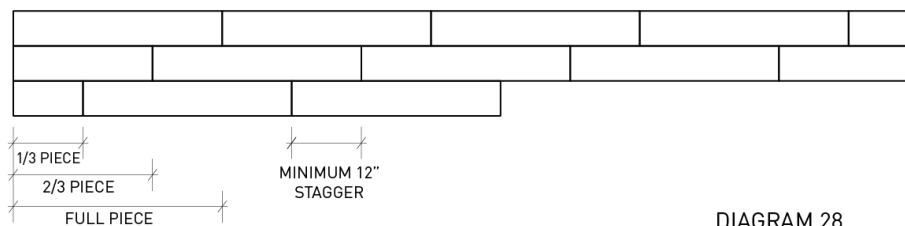

- The first row that is installed may need to be cut to a smaller width to avoid the last row in the room being very narrow
  - Measure the width of the room and divide by the width of a piece
  - *For example, if the width of the room is 10'2" and the pieces of flooring are 6"...*
    - **Do not:** install a full width piece on the first row and then end up with the last row being 2" wide
    - **Do:** Cut the width of the first row to 4" allowing the width of the last row to also be 4"
- Cut door jambs to allow flooring to slide underneath them
  - Lay a piece of flooring beside the door jamb and mark the height where the cut will need to be
  - Use a hand saw or a jamb saw to make this cut
- Use spacers where the flooring butts up to the wall to create a ¼" gap
  - These will be removed after the floor install is completed
  - This allows the whole floor to float and expand/contract over time
  - Spacers are usually included in laminate installation kits or scraps of flooring can be used
- See the following instructions for specifics on Laminate and Vinyl Plank

## Laminate

- For the first row:
  - The groove will be facing the room (See Diagram 29)
  - Work across the starting wall, interlocking pieces on the short edges
    - Pieces may slide together or need to be tapped together using the block and mallet from the laminate installation kit (See Diagram 30A)
    - Pieces at the end of the row can be tapped into place using the bar from the installation kit (See Diagram 30 B)
    - Another way to tap pieces into place is to use a scrap with the appropriate edge locked into place and to tap on that piece to avoid damage to pieces being installed (See Diagram 30C)



DIAGRAM 29

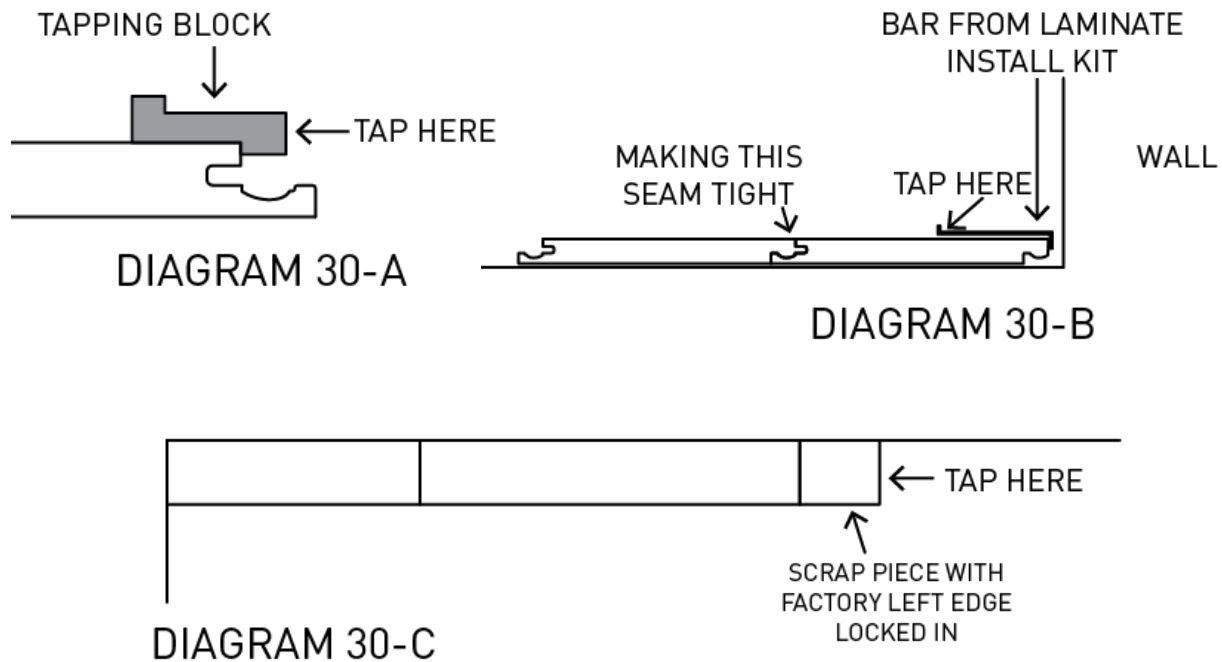

- Make sure that the finished surface of pieces line up on the short edges because being slightly off will make it difficult to install the next row
- Seams should be tight, you should not be able to tell where the seam is when running your finger over it
- The following rows:
  - Start with a piece that allows for the required 12" stagger
  - The tongue side of the next row of pieces will be installed to the groove of the previous row
  - Use scraps and tapping block/bar to make the seams tight
  - Continue down the row, installing full pieces until a full piece will no longer fit
  - When installing full pieces, (depending on the way the locking seam on the short edge works - manufacturers vary), try to get the long seam tight and then use a scrap to tap pieces into position to tighten the short seam
- Rather than measuring each piece at the end of each row when there is less than a full length remaining, you can rotate a full piece 180° and hold it into place, make a mark where this piece and the previous overlap, this will be the mark for the cut
- **Cut edges of laminate should always be towards the wall, never in the field**
  - Be cautious when working that all edges are interlocking appropriately
  - Be careful when cutting that cuts are being made off the correct side so that the necessary factory edge is remaining



## Vinyl Plank

- **Vacuum/sweep before and during installation, particles that get on the sticky tab will keep it from adhering well**
- For the first row:
  - The adhesive tab will be facing the room (See Diagram 31)
  - Work across the starting wall and overlap the adhesive tab of pieces on the short edges



DIAGRAM 31

- Seams
  - Seams should be tight, you should not be able to tell where the seam is when running your finger over it
  - If the seam is not tight, you can pull the pieces apart and try again, this may not be easy because of the adhesive seam
  - There is about a 15 minute window for working with these pieces before the adhesive material starts to cure
  - Lay a clean 2x4 over each seam and tap up and down the length of the seam to help seal the adhesive tabs
- Following rows:
  - Start with a piece that allows for the required 12" stagger
  - The non-tab side of the next row of pieces will be installed over the adhesive tab of the previous row (See Diagram 32)
  - Continue down the row and install full pieces until you reach the last piece in the row



DIAGRAM 32

- Rather than measuring each piece at the end of each row when there is less than a full length remaining, you can rotate a full piece 180° and hold it into place, make a mark where this piece and the previous overlap, cut here
- **Cut edges of vinyl should always be towards the wall, never in the field**
  - Be cautious when working that all edges are overlapping appropriately
  - Be careful when cutting that cuts are being made off the correct side and the necessary factory edge is remaining

# Baseboard

Additional information for baseboard/trim found on page 197

Baseboard can be either 3.25 MDF Baseboard or 1x4 material. Baseboard will be installed around the base of the wall to protect and cover the edge of flooring.

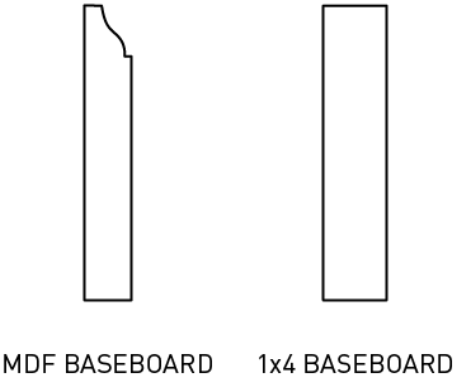

DIAGRAM 33

- Baseboard should be painted before it is installed and touched up after installation
- Baseboard should be attached with finishing nails into wall studs
  - Pre-drill holes before installing
  - Do not nail into the floor
- If using MDF Baseboard, corners should be mitered (See Diagram 34A)
- If using 1x4 Baseboard, corners can be butted together (See Diagram 34B)

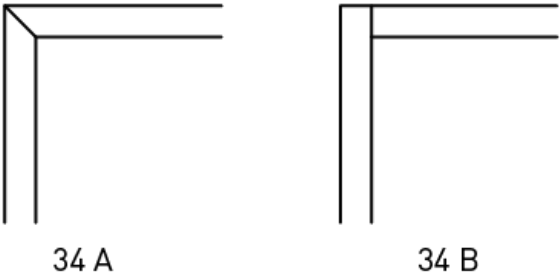

DIAGRAM 34

## Floor Covering (Laminate and Vinyl Plank) Materials

| <u>Quantity</u> | <u>Item</u>       | <u>Purpose/Notes</u>   |
|-----------------|-------------------|--|
| ___ SF          | Flooring          | Add 10% for waste<br><i>SF needed x 1.1 = Total Flooring to Order (SF)</i> |
| ___ SF          | Foam Underpad     | If needed for underneath laminate flooring                                 |
| ___ SF          | 6 mil plastic     | Vapor barrier, only if installation is over concrete subfloor              |
| ___             | Floor Registers   | Measure size for each one  |
| ___             | Transition Strips | Measure length for each doorway  |
| 1               | 2x4               | To tap seams of vinyl plank  |

### Underlayment:

#### **Lauan:**

|     |                |  |
|-----|----------------|--|
| ___ | Lauan          | <i>SF of room or area/32 SF(size of one piece) = # of Pieces</i> |
|     | Drywall Screws | To attach lauan  |

#### **Cement Board:**

|     |                     |   |
|-----|---------------------|---|
| ___ | Cement Board        | (if applicable) <i>SF of room or area/15(size of one piece) = # of Pieces</i> |
|     | Cement Board Screws | To attach cement board  |

**Baseboard materials list/recommended tools on page 204**

## Recommended Tools

### Safety:

Glasses  
Ear Plugs

### Power Tools:

(For Laminate and Underlayment)  
Laminate Saw or Miter Saw  
→ Finishing blade  
Table saw - to cut the length of pieces  
Jig saw - to cut notches around vents/etc.  
→ Wood Blade  
Circular Saw  
Drill/Impact Driver  
→ Phillips Driver  
→ Large bit to start holes for jig saw

### General Tools:

Basic Hand Tools (Tape measures, hammer, pencils, speed square, etc)  
Shop Vac or broom/dustpan - to clean floor before flooring install  
Hand saw or jamb saw - to cut the door jamb  
Laminate installation kit (For laminate only)  
Extension Cords  
Saw Horses  
Utility Knife  
Hack Saw - to cut transition strips





# Walls, Windows, & Doors

## Walls

**Why walls?** Walls support the roof and provide means for insulating the home.

### Safety

- If repair needs to be made to load bearing walls, make sure that kickers are used to support the weight of the roof (instructions for kickers are on page 35)
  - Load bearing walls are typically parallel to the ridge of the roof
- If cutting into siding/sheathing or drywall for wall repair, be cautious of wires that may run through the wall

### Wall Project Planning

- During repairs will any temporary support be needed?
- Is it an exterior wall/will it need to be insulated?
- Will there be a window or door?
- Is there room to build the wall then raise it into place?
- Will any permits/inspections be needed?
- Will band joist/floor system need repair as well?

### Measurements Needed

- Square footage of sheathing/siding/drywall to be repaired
- Size/spacing of studs to be repaired
- Measurements of windows/doors if applicable

## Quality Control

- Place a bead of caulk on floor before raising the wall into place
- Does the wall have/need a double top plate?
- Check spacing for studs (16" o.c.)
- Make sure necessary blocking is added for siding and drywall
- Make sure headers are supported by jack studs

## Common Mistakes

- Double top plate not overlapping intersecting walls
- Studs not spaced appropriately
- Blocking not added and siding/drywall not adequately secured
- Studs not plumb

## After Work is Complete Quality Control Check

- Are there nailers for drywall in the corners?
- Are double top plates connecting the walls?
- Will wall need to be insulated before drywall?

Headers are horizontal beams in walls that carry the roof load over window or door openings (See Diagram 3). The table below helps determine the size of material needed for headers in different applications.

| <b>Allowable Span for Double Headers</b> |                             |                        |                          |
|--|-----------------------------|------------------------|--------------------------|
| <b>Dimension of Lumber</b>               | <b>Supporting Roof Only</b> | <b>One Story Above</b> | <b>Two Stories Above</b> |
| 2x6                                      | 4'                          | 2'                     | N/A                      |
| 2x8                                      | 8'                          | 6'                     | 4'                       |
| 2x10                                     | 10'                         | 8'                     | 6'                       |

## Wall Components

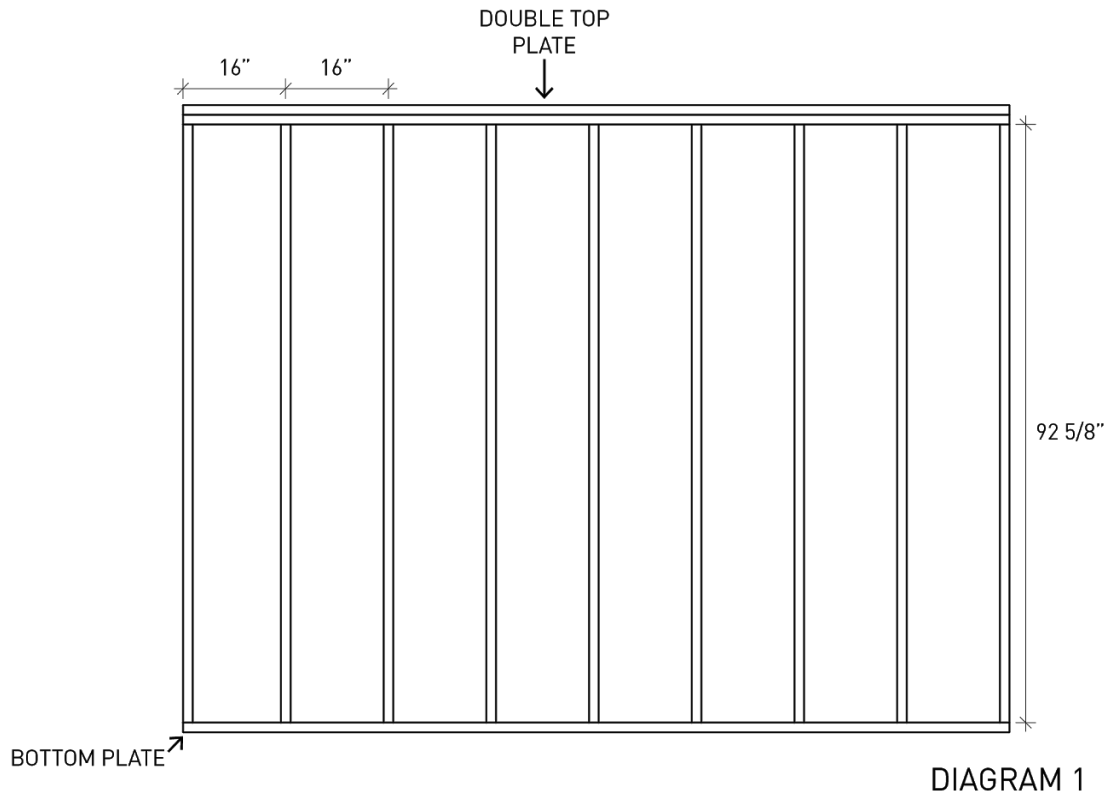

- Bottom Plate
  - Sits on subfloor
  - Bottom of studs rest on bottom plate
- Studs
  - Vertical members of a wall
  - Typical length of pre-cut studs is 92 5/8"
  - When combined with double top plate and bottom plate, finished wall height is just over 8'
  - Most commonly studs are placed 16" or 24" on center
  - Should be plumb
- Double Top Plate
  - The lower top plate holds the top of the studs
  - The upper top plate is added after the walls are constructed and is used to tie intersecting walls together
- 2x4s are the most common lumber size for wall framing

## **Building New Walls**

Ideally, it is best to build walls laying on flat ground then move them into place.

**Top and bottom plate:** (See Diagram 2)

- Top and bottom plate should be cut to the same length
- Line up one end of the top and bottom plate well and then tack them together temporarily with a screw or nail
- Measure and cut through both plates for a wall at the same time

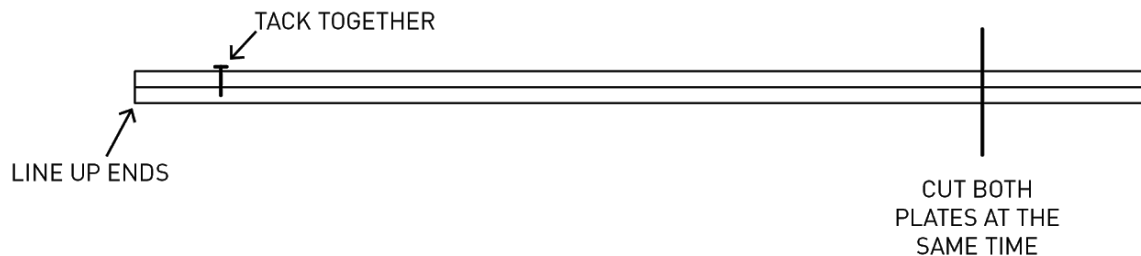

DIAGRAM 2

**Window openings:** (See Diagram 3)

- The rough opening for a window should be 1" taller and 1" wider than the actual window size
- The bottom of the window must be at least 18" off of the floor
- Determine what the height of the window will be and if possible line up the top of the windows and doors on a wall/in a room
- In bedrooms at least one window or door must meet egress requirements, allowing someone to get out of it in an emergency
  - Check with local inspector for these requirements



- Window framing:
  - King studs: run from top plate to bottom plate, beside jack studs
  - Jack studs: run from bottom plate to bottom of header
    - The spacing of jack studs should be the width of the rough opening inside to inside
  - Header: beam that sits on top of jack studs, between king studs, and supports the weight of the roof across the window opening (instructions for building below)
  - Sill: sits on top of cripples between jack studs and forms bottom of rough opening
  - Cripples: short studs that run from sill to bottom plate or header to top plate

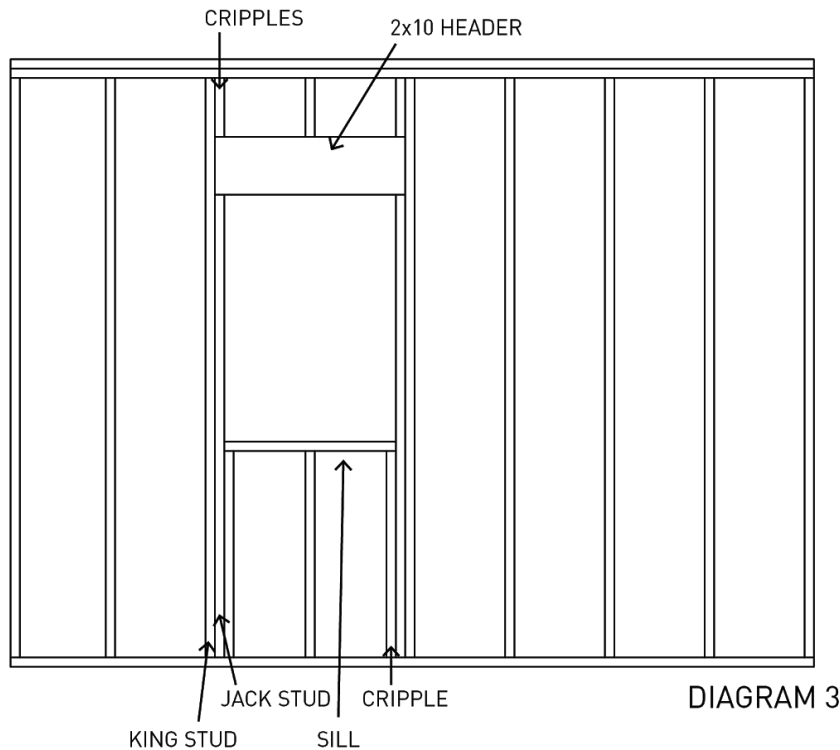

**Door openings:** (See Diagram 4)

- Door framing will vary depending on whether the door is in a load bearing wall, doors on non-load bearing walls can be framed differently
- The rough opening for a door should be 2" wider and 2" taller than the door:
  - The bottom plate of the wall should be left in place until the wall is stood and secured, then cut out using a reciprocating saw
  - Account for this 1 1/2" when making the rough opening (jack stud should only be cut 1/2" longer than the actual door size and the other 1 1/2" will come from the bottom plate being cut out)
- Think about which way the door will swing when determining the location of the door frame

**Framing for doors in load bearing walls: (See Diagram 4A)**

- King studs: run from top plate to bottom plate, beside jack studs
- Jack studs: run from bottom plate to bottom of header
  - The spacing of jack studs should be the width of the rough opening inside to inside
- Header: beam that sits on top of jack studs, between king studs and supports the weight of the roof across the door opening (instructions for building below)
- Cripples: short studs that run from header to top plate

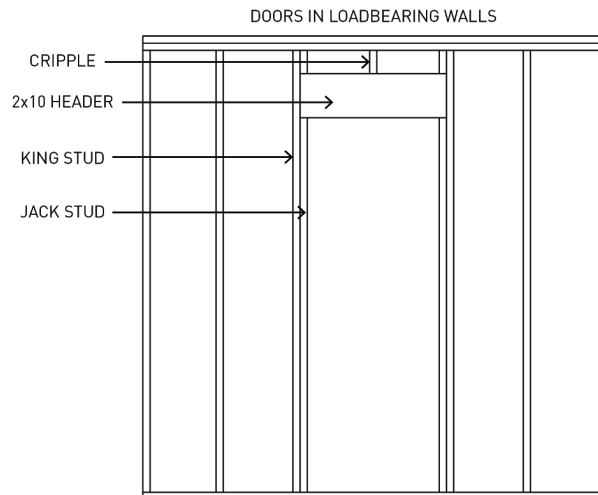

DIAGRAM 4-A

**Framing for doors in non-load bearing walls: (See Diagram 4B)**

- King studs: run from top plate to bottom plate, beside jack studs
- Jack studs: run from bottom plate to flat 2x4 at top of door opening
  - The spacing of the jack studs should be the width of the rough opening inside to inside
- Flat 2x4: sits on top of the jack studs, between king studs
- Cripples: short studs that run from the flat 2x4 to the top plate

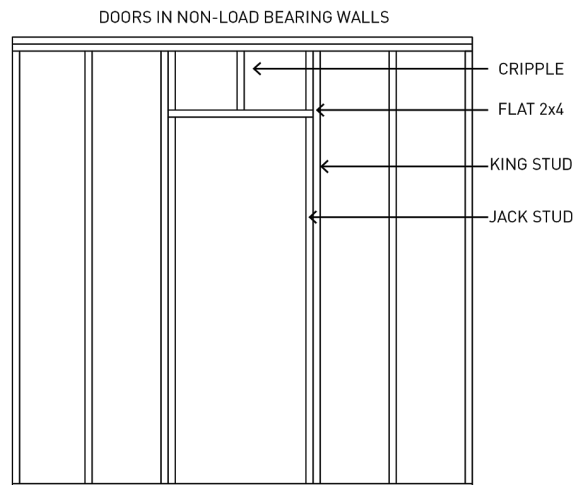

DIAGRAM 4-B

**Laying out plates:** See Diagram 6

- Mark on one plate for where studs will fall, marks can be transferred from one to the other
- It is important when laying out the studs to do it in a way that when sheathing and drywall are hung that their ends will fall on studs (8' from the corner should fall in the center of a stud)
- Hook the tape measure on the end of the plate and make marks  $\frac{3}{4}$ " before 16" spacing
  - $\frac{3}{4}$ " is half of the width of a stud
  - These marks are where the leading edge of the studs
  - Marks will be at  $15 \frac{1}{4}$ ",  $31 \frac{1}{4}$ ",  $47 \frac{1}{4}$ ",  $63 \frac{1}{4}$ ",  $79 \frac{1}{4}$ ",  $95 \frac{1}{4}$ " etc. (See Diagram 6A)
  - Transfer these marks all the way across the plate (See Diagram 6B)
  - Use a speed square to mark the other side of the stud (See Diagram 6C)
    - "Xs" indicate where studs will sit
- Determine where window/door openings will be
  - Make marks on the plate for the king/jack/cripple studs
  - If possible, a stud in the regular layout can double as a king stud
- Lay plates beside one another and transfer marks onto the blank plate using a speed square
  - Make sure ends are flush

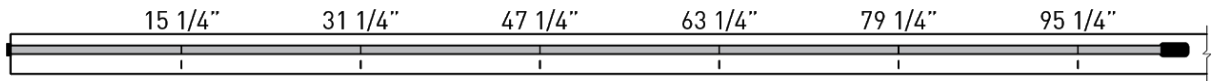

DIAGRAM 5-A

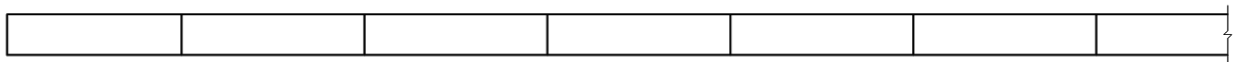

DIAGRAM 5-B

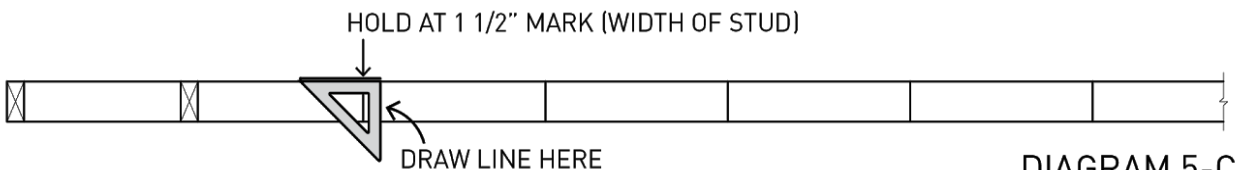

DIAGRAM 5-C

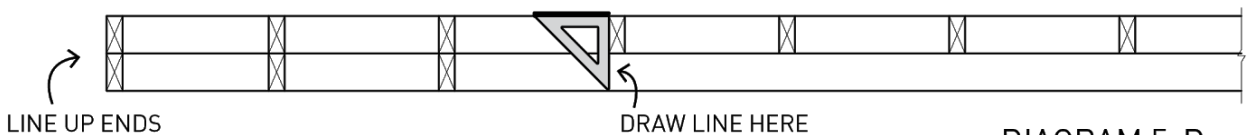

DIAGRAM 5-D

**Build headers:** (See Diagram 5)

- Headers should be a double 2x10 with a strip of 1/2" OSB or 1/2" blue board in between
- The length of the header should be the width of the rough opening plus 3"
- Pieces should be glued together with construction adhesive
- Fasten header together with 16d nails

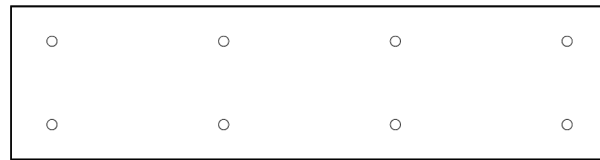
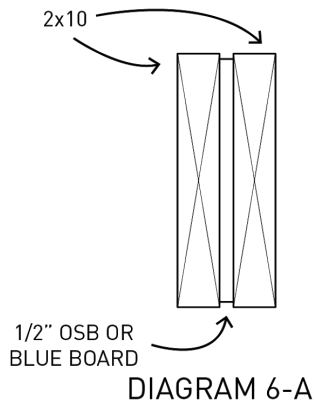

DIAGRAM 6-B

**Construct wall:**

- Cut the components (jacks/cripples/etc.) to length based on the rough opening
- Studs will be fastened into place using 16d nails, fastened through the face of the plate
  - Use 2 nails into each end of the stud
- Lay the top plate (second top plate will be added later), bottom plate, studs, and door/window components forming the wall shape on the ground
- Order of installation:
  - Place king studs first
  - Add header/flat 2x4 , fastening in through the king studs
  - Install jack studs, butting up underneath header/flat 2x4
  - Install sill and cripples at bottom of wall, fastening through sill into top of cripples
  - Install cripples over the header, toe-nail into header
  - Install regular studs at any time

**Ladder blocking:** (See Diagram 7)

- Ladder blocking will need to be installed anywhere an interior wall intersects an exterior wall
- Ladder blocking will be 2x4 blocks, spaced 24" on center, between studs that interior wall will intersect with

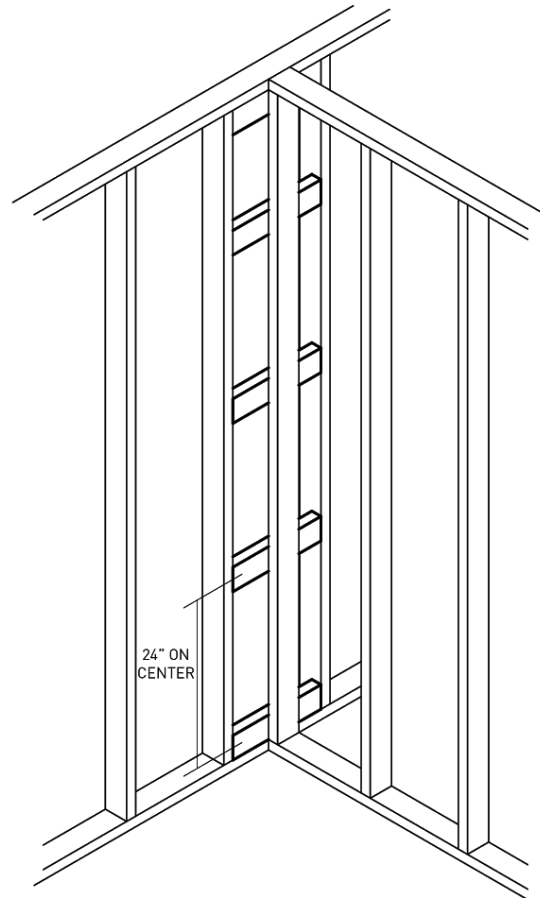

DIAGRAM 7

**Stand the wall:**

- For exterior walls, add a bead of caulk on the subfloor where the bottom plate will sit
- Raise walls into place
  - Attach to ladder blocking and/or other walls where they intersect using 16d nails
  - Attach to the subfloor, fastening into joists where possible
  - Add temporary bracing if needed to help support the wall until the double top plate is installed

**Corners:** (See Diagram 8)

- California corners can be used to create a nailer for drywall where walls intersect

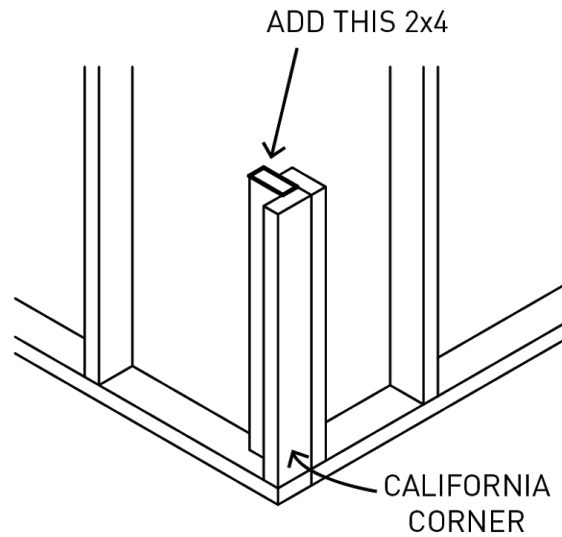

DIAGRAM 8

**Double top plate:** (See Diagram 9)

- Double top plate sits directly on top of top plate and is fastened with 16d nails
- This plate is used to tie walls together and hold them in place

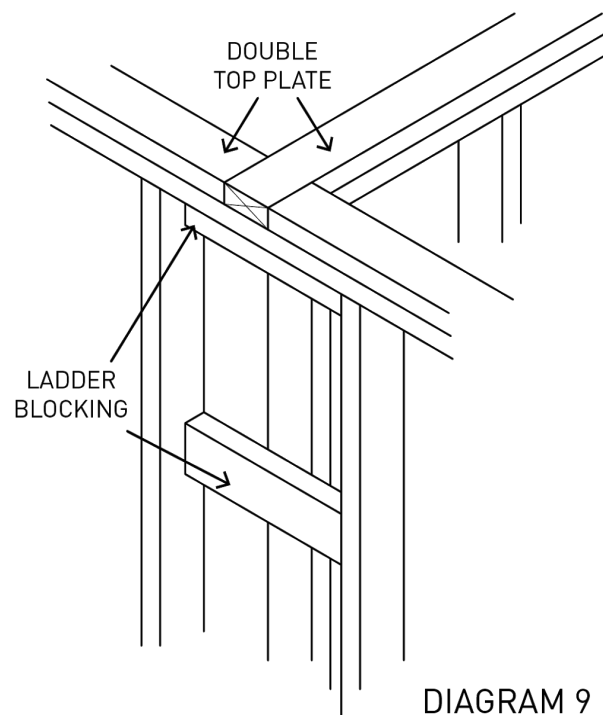

DIAGRAM 9

## Sheathing Walls

- Exterior walls should be sheathed with 7/16" OSB
- The sheathing provides lateral support and air sealing
- Plan layout of OSB
  - OSB will run horizontally, perpendicular to the studs
  - Rows of OSB should run from the bottom of the floor system to the top of the wall
  - Each sheet should cover at least 2 bays and 3 studs
  - It is best to avoid using small pieces of OSB if possible because there is greater strength with fewer seams
  - Seams should be staggered by at least 2 stud widths
- Install OSB
  - Start at the bottom of the floor system, installing lower courses first and working up the wall
  - Each 4' edge of the OSB should always land on a stud
  - Attach the OSB with 2" screws or 8d ring shank nails every 6" on the edges and 12" in the field
  - Cut out holes for vents/etc. using a jigsaw, start holes using a wide drill bit as needed
  - Continue installing OSB in rows; following the same process until a full row will no longer fit
    - For the last row, cut the OSB to width with the upper edge falling even with the top of the double top plate
- Seal all seams of OSB with tape or caulk to prevent unwanted air flow

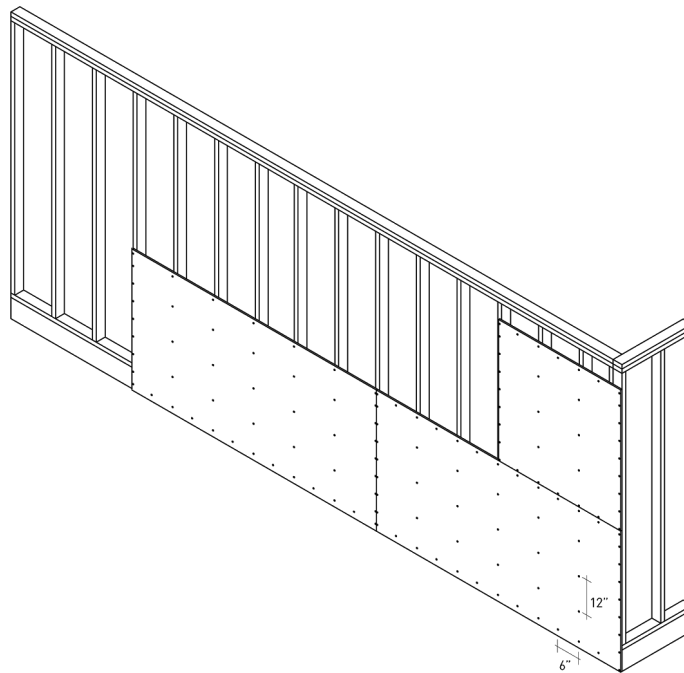

DIAGRAM 10

## Repairing Existing Walls

- If the bottom plate of the wall/or studs are to be removed to be repaired, temporary bracing must be added
  - If there is extensive damage to the bottom plate, there will likely also be issues with the floor system, see band joist repair (pg. 35) and floor repair (pg. 32)
  - Kickers can be installed (see page 37)
  - An interior temporary wall could be installed instead of kickers
    - Set back far enough from working area to still have access to repairs
    - Mount flat 2x4 on both ceiling and floor and wedge studs in between to hold the weight of the roof
    - This method should be used if replacing entire studs because kickers are fastened into wall studs
- Bottom plate repair (See Diagram 11)
  - Cut out damaged bottom plate and cut fasteners holding studs into bottom plate using a reciprocating saw
  - Only remove bottom plate in 8' sections at a time
  - When replacing bottom plate, make sure that ends of a new piece will fall under a stud, or add a block from the old plate to the new between studs
  - Attach to floor with 16d nails or 3" screws

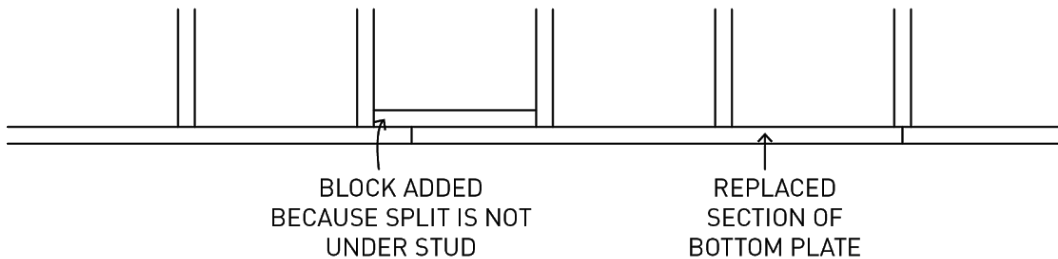

DIAGRAM 11

- Damaged studs can be cut and scabbed or replaced completely
  - Stud replacement
    - Remove existing stud, cutting or pulling fasteners in both top and bottom plate
    - Cut a new stud to length to fit between the top and bottom plate
    - Toe-nail stud into the top plate and bottom plate using 12d nails or 3" screws
  - Scabbing studs (See Diagram 12)
    - Remove the bad piece of stud
    - Replace the damaged piece with a new section
    - Add scabs on either side of the stud to brace the repaired stud
    - Scabs should extend 2' past the damaged area



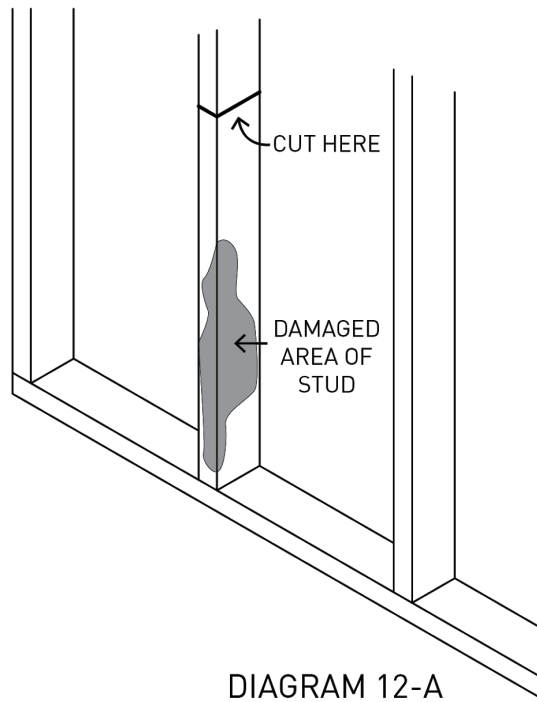

DIAGRAM 12-A

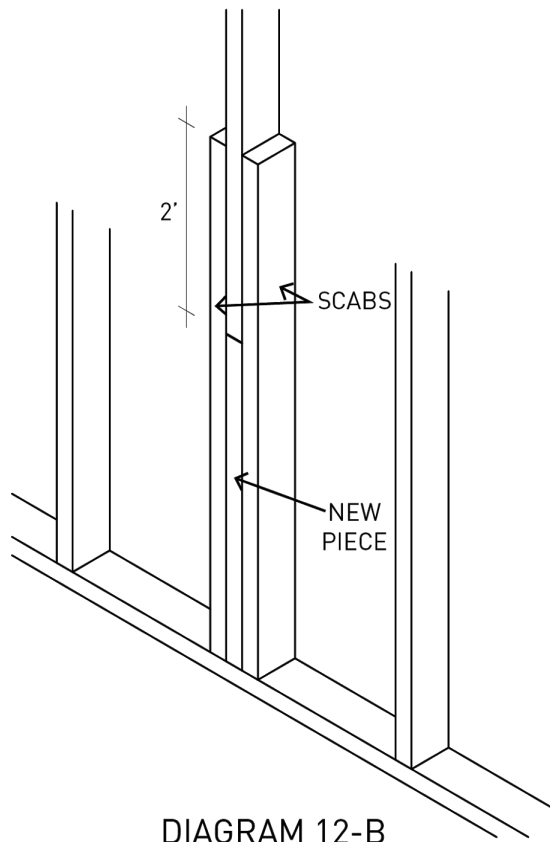

DIAGRAM 12-B

- Once all damaged components have been repaired, remove kickers/temporary support wall

## **Wall Material List**

| <u>Quantity</u> | <u>Item</u>           | <u>Purpose/Notes</u>   |
|-----------------|-----------------------|--|
| ___             | Studs                 |  |
| ___             | 2x4x___ WW            | Double Top/Bottom Plate  |
| ___             | 2x10x___ WW           | Header for Windows/Doors   |
| ___             | 7/16" OSB             | Wall Sheathing and Middle of Header<br><i>SF of wall/32 (SF in one piece) # of pieces needed</i> |
|                 | 16d Nails             | For attaching framing  |
|                 | 8d Nails              | For sheathing  |
|                 | Construction Adhesive | Under bottom plate of wall   |

## **Recommended Tools**

### **Safety:**

Glasses  
Gloves  
Earplugs

### **General:**

Basic Hand Tools (Tape measures, hammers, pencils, speed square, etc)  
Saw Horses  
Extension Cords/Splitters  
Caulk Gun  
Level  
Chalk Line  
Prybars  
Ladders

### **Power Tools:**

Miter Saw  
Circular Saw  
Reciprocating Saw  
→ Metal Cutting Blade - cutting nails while removing damaged areas  
→ Wood Cutting Blade

# Windows

**Why windows?** Windows allow sunlight, reducing energy demand and are a means of egress in case of emergencies.

## Safety

- Wear gloves if working with broken glass
- Be cautious while transporting and installing windows

## Window Project Planning

- Rough opening for window should be 1" wider and 1" taller than actual window
- Does window need to be an egress window?

## Measurements Needed

- Rough opening for window size

## Quality Control

- Make sure caulk is used on back side of window flange
- Use flashing tape to seal sides and top of window flange
- If shims are needed for a window without a flange install on sides and bottom but not top
- Make sure to seal space between window and framing (spray foam for windows and doors or fiberglass insulation)

## Common Mistakes

- Flashing tape installation done out of order
- Shims installed on all sides
- Regular spray foam used (Window/door spray foam should be used)

## After Work is Complete Quality Control Check

- Is window sealed/insulated well?
- Is install trim/casing on the inside and outside of the window?
- Does inside of window stay dry during rain?
- Does window open/shut properly?

# Installing Windows

## Windows with flanges

- 6" flashing tape should be used across the bottom and both sides of the window opening (See Diagram 13)
  - Piece across the bottom should be installed first
  - 3" of the tape should be folded into the window frame and the other 3" should be on the outside of the wall
  - Tabs should be cut in the tape and 6" of tape should extend past the window opening on the wall
  - Cut two bowtie shapes and add them to the bottom corners after the bottom and side strips of tape have been installed
  - Top pieces will be installed after window is installed

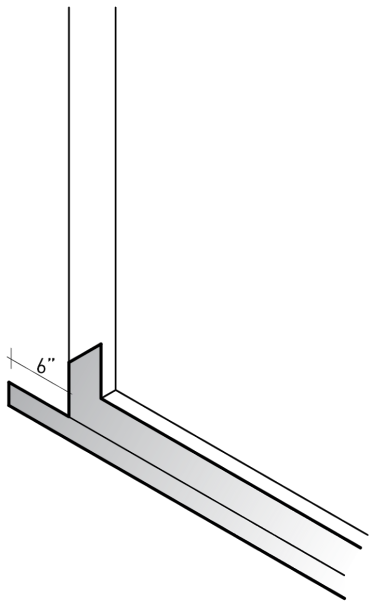

DIAGRAM 13-A

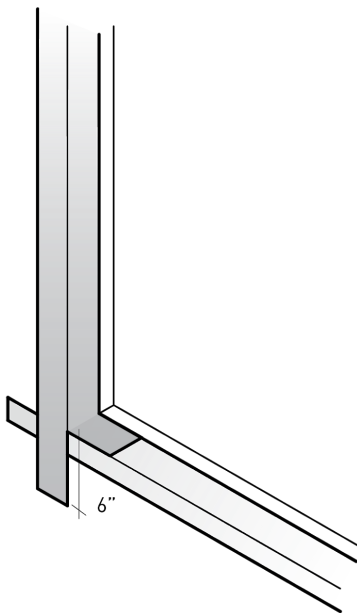

DIAGRAM 13-B

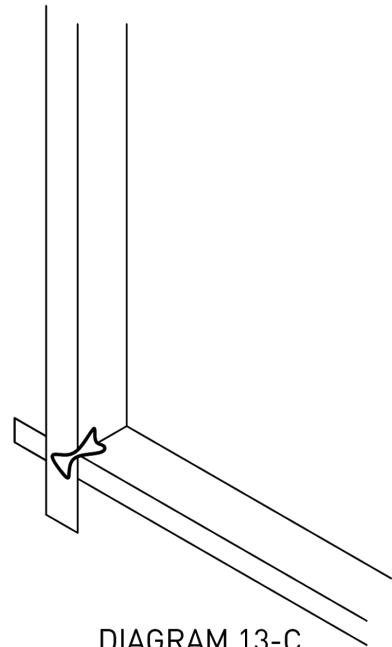

DIAGRAM 13-C

- Place the window into the opening
  - Tack in top corners and one bottom corner using 2 ½" exterior screws
  - Adjust to level and plumb using the three screws
- When the window is level and plumb, back the screws out enough to stick a caulk gun behind the window flange, without removing the screws all the way
- Run a bead of window caulk behind the top and sides of the window flange
  - Do not caulk along the bottom
- Fasten the screws back in and fill in every other hole around the flange with a screw
- Add a strip of flashing tape across the top of the window flange, extending 6" past the opening on either side

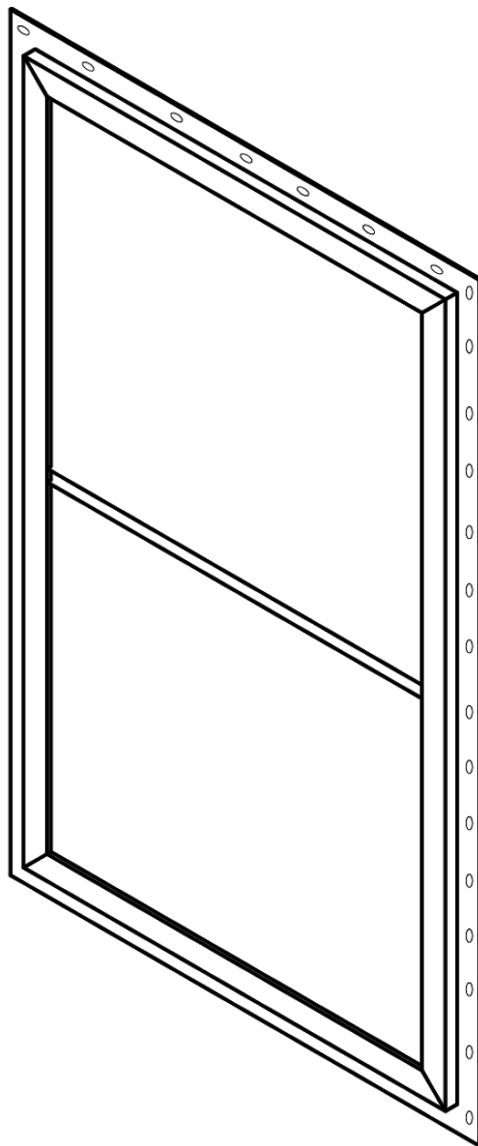

DIAGRAM 14

## Windows Without Flanges

- Windows that don't have flanges typically have brick molding on the outside
- Test fit the window into the space
- Add a bead of window caulk to the sides and top of the window where the brick molding will sit
- Place the window into the opening
- From the inside, add shims to the bottom and sides (none across the top)
  - Shim window to level and plumb
  - Trim shims so that they do not extend past the studs into the room
  - There should be at least three shims on both sides and on the bottom
- Attach the window to the rough opening of the frame through the sides, top and bottom of the window using 12d finish nails
  - Put at least three nails into each side/top/bottom
- From the inside, use window/door spray foam (not regular spray foam) to fill voids between the window and the framing

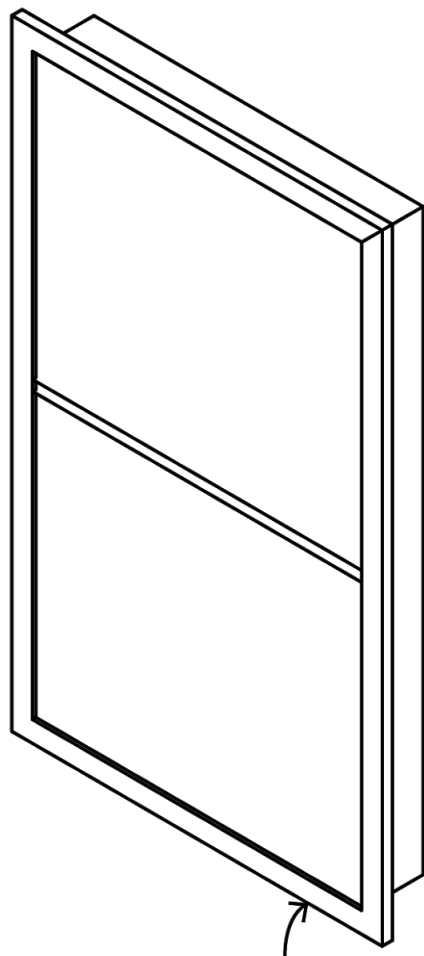

DIAGRAM 15

## **Window Material List**

| <u>Quantity</u> | <u>Item</u> | <u>Purpose/Notes</u> |
|-----------------|-------------|----------------------|
|-----------------|-------------|----------------------|

### **Flange Windows**

Window  
Flashing Tape  
2 ½" Deck Screws  
Window Caulk

### **Windows Without Flanges**

Window  
Shims  
Window Caulk  
12d Galvanized Finish Nails  
Spray Window/Door Foam

**See Trim section on page 204 for materials list and recommended tools**

## **Recommended Tools**

### **Safety:**

Glasses  
Gloves

### **General:**

Basic Hand Tools (Tape measures, hammers, pencils, speed square, etc)  
Caulk Gun  
Level  
Utility Knife  
Ladders

### **Power Tools:**

Drill  
→ T-25 Driver to match screws for installing window (For flange windows)  
→ Small drill bit to pre-drill for finish nails (For non-flange windows)

# Doors

**Why doors?** Exterior doors allow access in and out of the home and interior doors allow for privacy in the living space.

## Safety

- Communicate with homeowners and workers when a door is being removed
- Be careful of pinch points when moving a door that is attached to frame

## Door Project Planning

- Rough opening should be 2" wider and 2" taller than the door
- Does the door need to be replaced or could it be repaired?
- At what phase of the project will this be done?
  - Should be before siding and before porches (especially if any repair needs to be done to the frame)
- Doors for accessibility should be 36" wide

## Measurements Needed

- Size of rough opening
- What swing will the door be?

## Quality Control

- Is there caulk under the sill?
- Make sure the door is shimmed to plumb
- For exterior doors make sure that shims are behind hinges
- Make sure to insulate between the door jamb and frame (use window/door specific spray foam)

## Common Mistakes

- Door slightly sloped and not opening/closing properly
- Shims anywhere between the frame and rough opening (not behind hinges)
- Regular spray foam insulation used

## After Work is Complete Quality Control Check

- Does the door open and close well?
- Is the lock/knob working correctly?
- Are there any gaps around the door that need to be insulated?



## Hanging Doors

### Door Swing

- Door swing is which way the door will swing when it opens
- To determine swing:
  - Stand with your back to where the hinges will be
  - Move whichever arm is on the “door side” the direction that the door will swing
  - If your right arm was used, then the door is a right hand swing (and vice versa for left)

### Exterior Doors

- Exterior doors installed should be pre-hung doors
- Most common exterior doors are 36” wide, 6’8” tall, and 1 ¾” thick
- Installation
  - Test fit the door into the opening
  - Add a generous bead of caulk under the sill and on the wall on the sides/top where it will be covered by the brick molding around the door
  - Move the door into place
  - Add shims behind the hinges until the door is plumb
  - When door is plumb, remove one screws from each hinge and replace with a 3” screw that attaches into stud
  - Close the door and look at the gap/reveal
    - This gap should be the same all the way around the door
    - Add shims on the side opposite the hinges until the gap is the same all the way around the door
  - On the side opposite the hinges, pull back the weather stripping
    - Attach with 3” screws behind the weather stripping
    - 3 screws should be installed (roughly same heights as the hinges)
- Add window/door spray foam (not regular spray foam) to fill the gap between the door and framing
- Install exterior lockset according to manufacturer's instructions

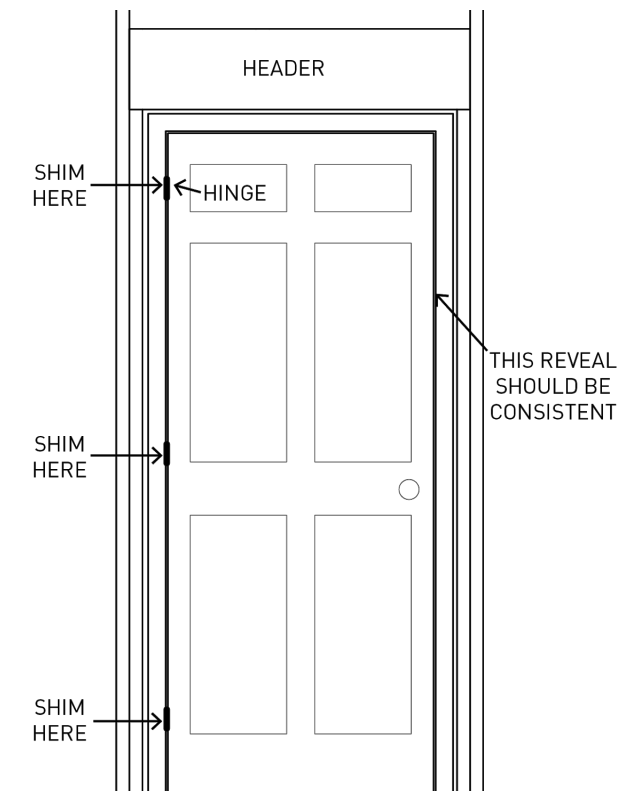

DIAGRAM 16

## Interior Doors

- Interior doors should be pre-hung
- Standard size interior doors are 36" or 32" wide, 6'8" tall, and 1  $\frac{3}{8}$ " thick
- There should be a minimum  $\frac{3}{4}$ " clearance underneath interior doors
- Installation
  - Move the door into place
  - Sit the bottom of the door on top of a couple shims to lift it off the frame
    - This is a greater concern if finished flooring will be installed after the door is hung, this creates space for it
  - Add shims behind the hinges until the door is plumb
  - When door is plumb, remove one screw from each hinge and replace with a 3" screw that attaches into stud
  - Close the door and look at the gap/reveal around the door
    - This gap should be the same all the way around the door
    - Adjust this gap by adding/removing shims underneath the jamb opposite the hinge side
    - Adjust until the gap is consistent
  - Attach door frame into stud with 12d finishing nails
    - Attach into side that will be covered by door when it is closed
    - Pre-drill holes so that the wood does not split
    - Use a nail punch to sink the nails just below the surface
    - Cover nail holes with putty
- Install interior lockset according to manufacturer's instructions

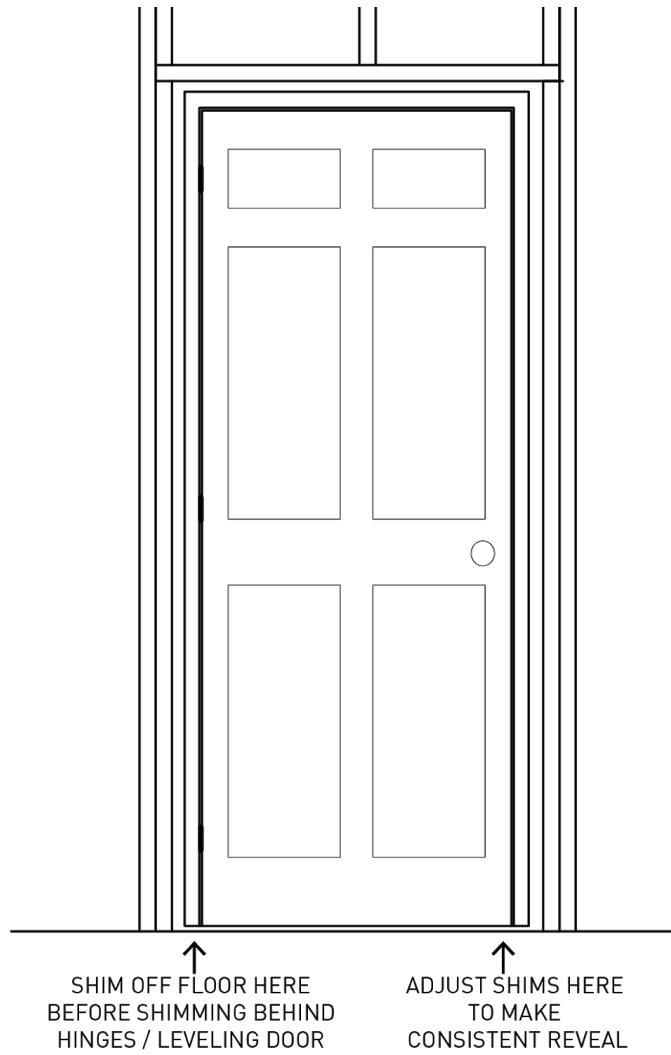

DIAGRAM 17

## **Door Material List**

| <u>Quantity</u> | <u>Item</u>            | <u>Purpose/Notes</u> |
|-----------------|------------------------|----------------------|
|                 | Door                   |                      |
|                 | Shims                  |                      |
|                 | 3" Screws              | (for exterior doors) |
|                 | Door Caulk             | (for exterior doors) |
|                 | 12d Finish Nails       | (for interior doors) |
|                 | Window/Door Spray Foam |                      |
|                 | Door Lockset           |                      |

## **Recommended Tools**

### **Safety:**

Glasses  
Gloves

### **General:**

Basic Hand Tools (Tape measures, hammers, pencils, speed square, etc)  
Phillips Head Screwdriver - for installing lockset  
Caulk Gun  
Level  
Utility Knife  
Ladders

### **Power Tools:**

Drill  
→ Phillips Driver - for removing existing door  
→ T-25 Driver - for deck screws (exterior doors only)  
→ Small Drill Bit - to pre-drill for finish nails (interior doors only)





# Roofs

**Why Roofs?** Roof repair and covering keep the living area dry. Moisture from roof leaks can lead to structural damage and allow mold to grow and compromise air quality in the living space.

## Section Contents:

|                |     |
|----------------|-----|
| Roof Structure |     |
| Roof Framing   | 90  |
| Roof Decking   | 94  |
| Roof Venting   | 96  |
| Roof Covering  |     |
| Tin Roofing    | 99  |
| SBS Roofing    | 114 |

## Safety

- ASP does not work on roofs of 2 story homes
- Any roof with a peak more than 20' high, eaves more than 12' high, or with a pitch greater than 4:12 should not be worked on without approval from a construction consultant or the HRC
- Roof jacks should be installed while working on roof
  - Nail into rafters with 16d nails (do not pound all the way down or they will be difficult to remove)
  - 2x6s fit into the "j" portion to stop falls
- Bats, bees, etc. can live in attic spaces
  - Have wasp spray on hand if opening up decking into attic space
- Before adding/changing to roof structure significantly, check the floor system (band joist) and foundation to ensure that the new weight can be adequately supported



- Wet roofs are extremely slick - do not work on roofs if they are wet
  - Allow dew to dry before working in the mornings
- Sawdust, shingle debris, mud or any other matter can make the roof surface slick
  - Use a push broom to clean off roof surface if it gets slippery
- Mark weak areas with bright spray paint so they can be avoided
- Ladders
  - Extension ladders should extend 3' above the roofline
  - Set up the ladder so that both feet are firmly on the ground, dig out one side with shovel or hammer claws if needed
  - Hold the ladder while someone is on it
  - Set up ladder so when your feet are at the base and you hold your arms straight out, they just touch the sides of the ladder
- Roof work is hot, ensure appropriate measures are being taken to prevent heat injuries

# Roof Structure

## Roof Framing

Plans for any roof structure repair or re-pitch should be made with Construction Consultant or HRC.

### Gable/Rake/Eave

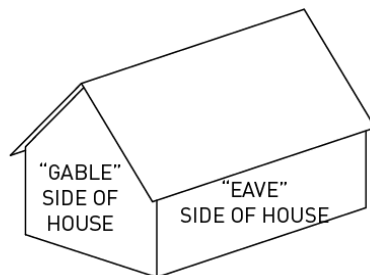

DIAGRAM 1

**Ceiling Joists** (See Diagram 2)

- Size of lumber required is listed in the span chart below
- Rest on top of load bearing walls
- Run perpendicular to the ridge of the roof
- Depending on the size of the rafters, the ceiling joists may be angled so that they do not interfere with the slope of the roof
- Spacing for ceiling joists is typically 16" or 24" on center
- Ceiling joists may be spliced over interior load bearing walls

| <b>Ceiling Joist Span Chart</b> |                     |                           |                  |
|---------------------------------|---------------------|---------------------------|------------------|
|                                 |                     | Span for Southern Pine #2 |                  |
| Joist Size                      | Spacing (On Center) | Limited Attic Storage     | No Attic Storage |
| 2x4                             | 16"                 | 8'                        | 10'9"            |
|                                 | 24"                 | 6'7"                      | 9'3"             |
| 2x6                             | 16"                 | 12'                       | 16'11"           |
|                                 | 24"                 | 9'10"                     | 13'11"           |
| 2x8                             | 16"                 | 15'3"                     | 21'7"            |
|                                 | 24"                 | 12'6"                     | 17'7"            |
| 2x10                            | 16"                 | 18'1"                     | 25'7"            |
|                                 | 24"                 | 14'9"                     | 20'11"           |

**Rafter** (See Diagrams 2 and 3)

- Size of lumber required is listed in the span chart below
- Run from ridge to eave and rest on the top plate of exterior walls
- Rafters may have a birdsmouth cut where they rest on top of the wall (See Diagram 2) or they may be attached with hurricane ties
- Spacing for rafters is typically 16" or 24" on center
- Where the rafter meets the ridge and the tail of the rafter that overhangs the wall should both be cut plumb

| <b>Rafter Span Chart</b>   |                     |                       |
|--|---------------------|-----------------------|
| (Ceiling attached to rafters, ground snow load 30 psf. Southern Pine #2) |                     |                       |
| Rafter Size  | Spacing (On Center) | Span for Souther Pine |
| 2x6  | 16"                 | 10'0"                 |
|  | 24"                 | 8'2"                  |
| 2x8  | 16"                 | 12'8"                 |
|  | 24"                 | 10'4"                 |
| 2x10   | 16"                 | 15'1"                 |
|  | 24"                 | 12'3"                 |

**Ridge Beam** (See Diagrams 2 and 3)

- Should be one dimensional lumber size larger than rafters
- May extend past exterior walls on gable sides of home to support fly rafters

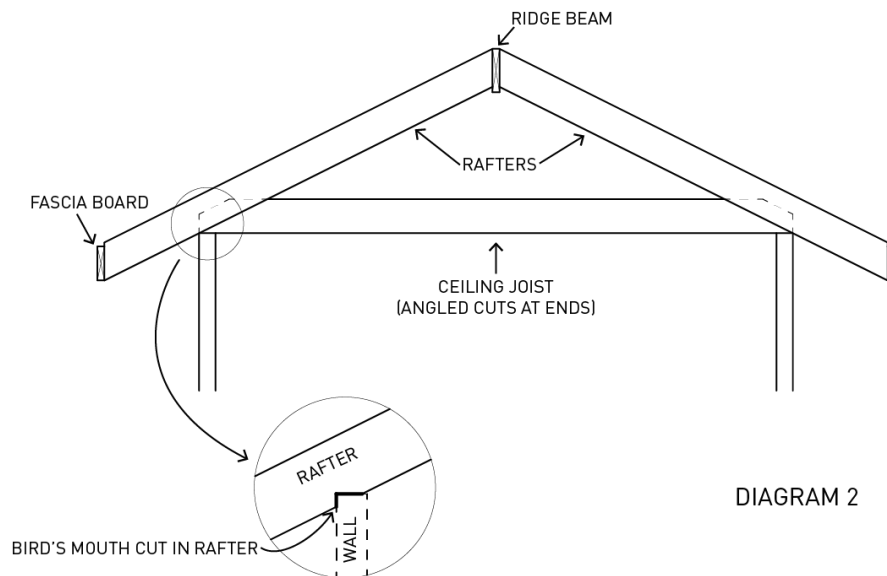



## Fly Rafter (See Diagram 3)

- Furthest outside rafter on the gable ends of a roof that creates overhang
- Can be supported by “lookouts” which are notched into the tops of previous rafters to support this fly rafter or may be supported by blocking between this and the previous rafter

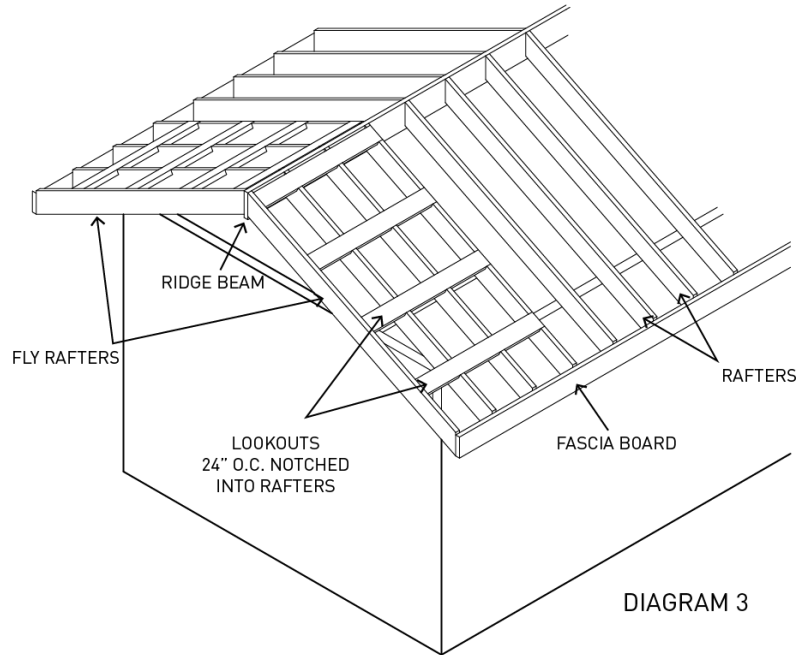

## Fascia Board

(See Diagram 2s and 3)

- On the gable ends the fly rafter is the fascia board/sub-fascia
- On the eave ends a fascia board covers the ends of the rafters
- This is what soffit is attached to
- The material may be 2x or 1x
- White wood should be used and painted or covered with soffit and metal fascia

## Pitch

- The pitch of the roof is the measurement of its slope (rise/run)
- For roofs, the pitch is typically referred to by how many feet the roof drops over a 12' span, so a roof that drops 3' over a 12' distance would have a 3:12 pitch
- A pitch can be determined by holding a level with one end touching the roof and then measuring down to the roof (See Diagram 4)
  - Convert the fraction so that the denominator is 12'
  - For example, if the level used is a 4' level and the distance between the bottom of the level and the roof is 1' the rise/run is 1'/4'. Multiply both the rise and run by 3 (this makes the denominator 12') and the result is 3'/12' meaning the the rise of the roof is 3' for every 12' of length. The pitch is a 3:12.

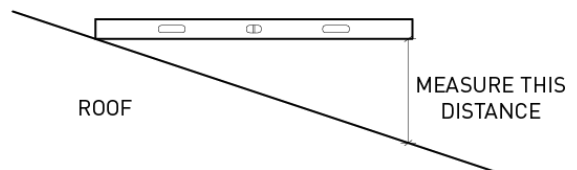

DIAGRAM 4

# Roof Decking

Roof decking is the solid surface of the roof that sits on the rafters. Typically new roof decking installed will be 4'x8' sheets of 1/2" OSB. Older roofs may have decking that is a 1x material that will be 3/4" thick rather than 1/2" thick.

## New Decking Installation

(See Diagram 5)

- Plan layout of OSB
  - Each sheet should cover at least 2 bays and 3 rafters
  - Avoid using small pieces of OSB because there is greater strength when there are less seams
  - Seams should be staggered by at least 2 rafter widths
- Install OSB
  - Measure 48" up from the outside of the fascia board on each gable end of the roof and snap a chalk line across the rafters
    - This mark indicates the top of the first row of decking
  - OSB will run perpendicular to the rafters
  - Each 4' edge of the OSB should land on a rafter
  - Attach the OSB with 2" screws or 8d ring shank nails every 8"
  - Place H-clips on upper edge of OSB in every bay before installing the second row of OSB (See Diagram 6)
    - H-clips add stability by providing edge support to decking and allow for expansion of OSB
  - For the second row of OSB:
    - Stagger the short seams by at least 2 joist widths
    - Slide pieces into the H-clips
  - Cut out holes for vents/etc., start the hole with a wide drill bit and cut to shape with jigsaw or a hole saw
  - Continue installing OSB in rows and following the same process until a full row will no longer fit
    - For the last row, cut the OSB to width with the upper edge falling 2" short of the true ridge, this will allow for venting

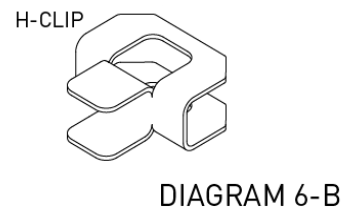
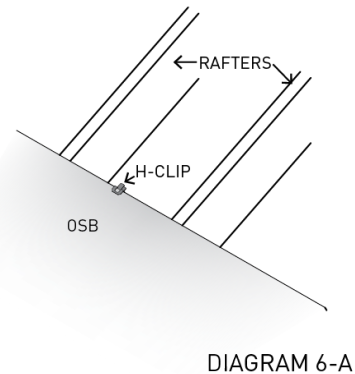
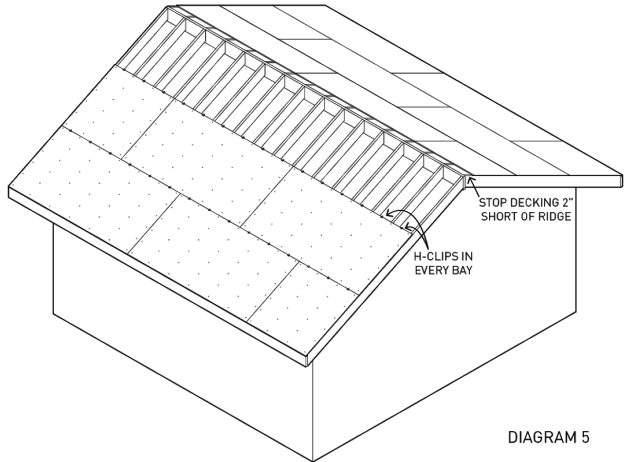

## **Decking Repair** (See Diagram 7)

In an effort to create solid patches with fewer seams, the minimum area that should be replaced at any time is a half sheet of OSB.

The material being used to patch should be the same thickness as the material on the roof

- Mark the area to be removed
  - Look at the fasteners through the existing decking to locate the rafters
  - Use a framing square to make the marks square and a chalk line to transfer the lines
  - Plan the replacement piece so that two edges will fall on top of rafters
- Set the depth of a circular saw to the thickness of the decking material and plunge cut into the decking to cut out the damaged piece
  - Before cutting, pull nails that will interfere with the cut to preserve the saw blade
- If needed, add nailers or blocking to the rafters that will support the edges of the piece
  - Nailers/blocking should be installed with 3" screws
- Cut the replacement piece of OSB to size
  - Dry-fit the new piece to make sure it fits in the space well
  - Attach the piece of OSB with 2" screws or 8d ring shank nails every 12"

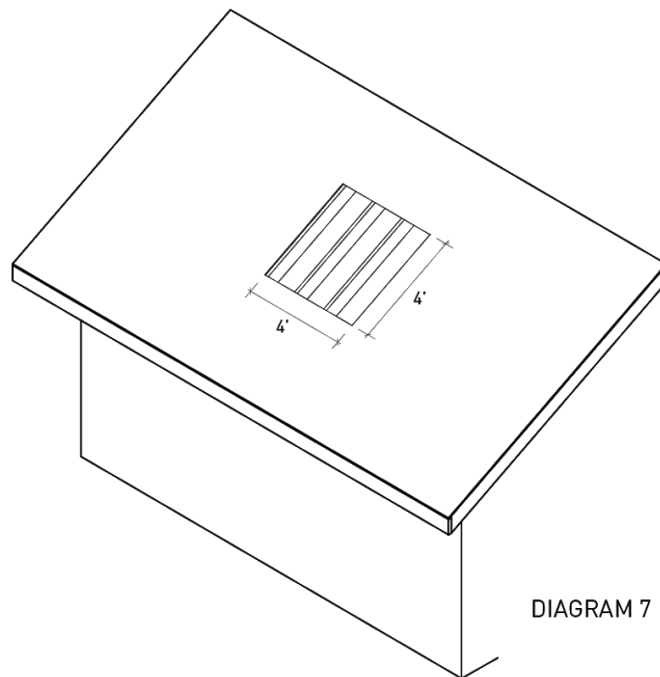

# Roof Venting

Adequate venting of a roof is important because it allows hot air to escape, cooling the house in the summer and reduces moisture build up in the attic that leads to issues with air quality and mold.

There is venting that allows air to flow into the attic space (Intake Vents) and venting that allows air to flow out (Exhaust Vents), both of which need to be incorporated into a roof system.

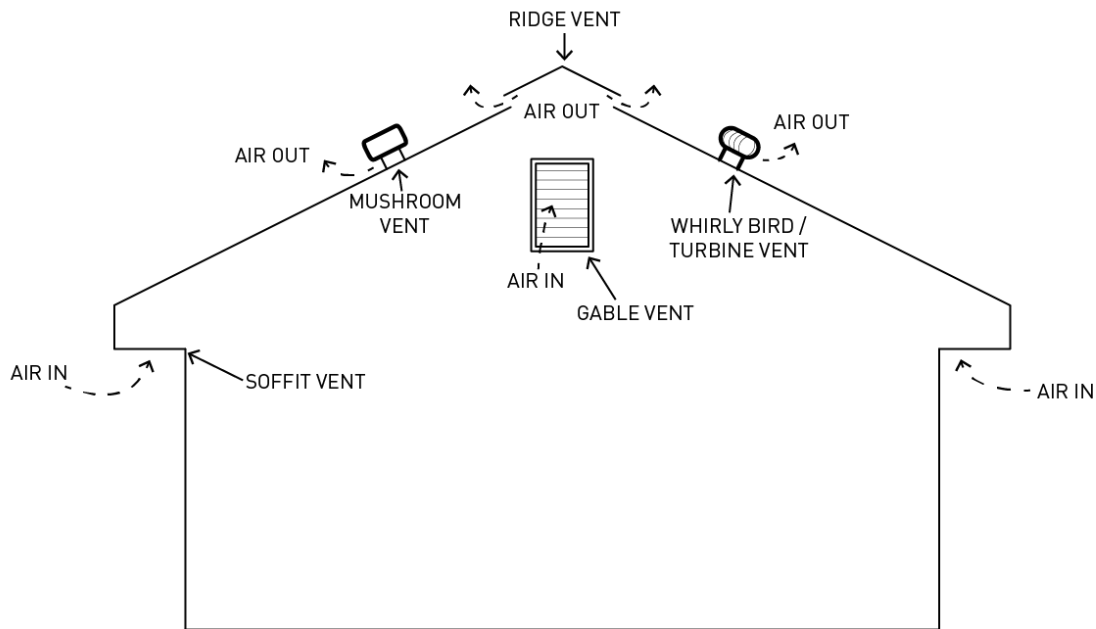

DIAGRAM 8

## Intake Vents

Ideally a home will have both soffit and gable vents.

- Soffit Vents
  - The soffit of a home is underneath the overhang of the roof
  - Soffit is only vented at the eave of the home and is unvented on gable sides (See Diagram 8)
  - Soffit venting is only effective if there is open space over the top of the wall into the attic, sometimes this space has been closed off (in which case, gable vents should be considered) (V is cut off in diagram (9A))

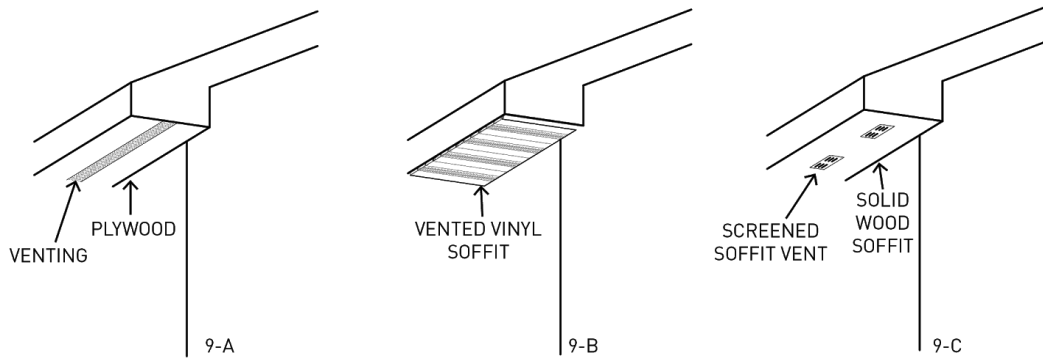
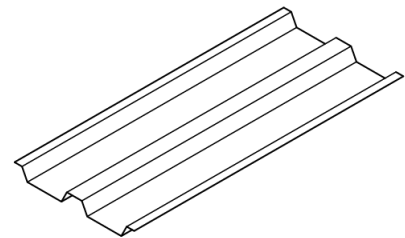

DIAGRAM 9

- There are a variety of different types of soffit vents (See Diagram 9)
- Installation instructions for vinyl soffit are on page 146 of the manual
- If solid wood soffit is installed, venting can be added to it
  - Screened soffit vents come in many sizes, the most readily available among suppliers are rectangle “screened soffit vents” usually 4”x16”
  - Cut holes in the soffit using a circular saw or jigsaw
    - Be careful and use safety glasses when cutting overhead
  - Add a bead of caulk around the hole before placing the soffit vent
  - Install the soffit vents with short exterior screws
  - There are also some small, round, screened soffit vents that can be installed by drilling holes with a hole saw and inserting the vents, these may be difficult to find



- Baffles (See Diagram 10)
  - Baffles are styrofoam channels, attached to the bottom of the roof decking over the exterior wall that allow air to move from the soffit area to the attic
  - Baffles should be installed if insulation interferes with the flow of air from soffit to attic
  - Baffles should extend from soffit about 3’ into the attic
  - Attach baffles with staples
  - Install a baffle in every bay between rafters
  - Baffles can be used with any type of soffit

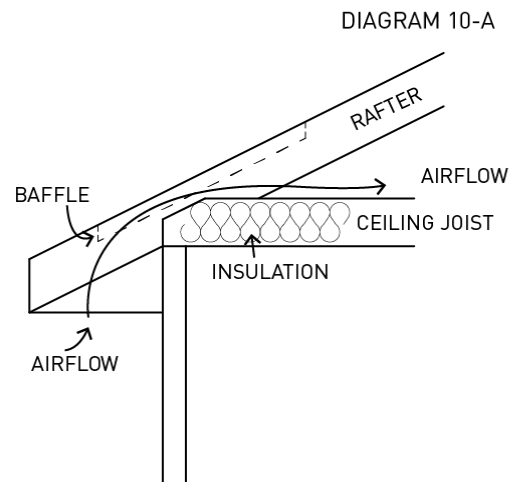

DIAGRAM 10-B

- Gable Vents (See Diagram 8)
  - Placed on gable walls at a height that they open into the attic space
  - There should be a gable vent on both sides of the home, directly across from one another
  - There are many different types of gable vents. The type of siding may dictate which gable vent should be used.
  - To install gable vents:
    - Plan how big of a gable vent you need. Typically a 12"-18" rectangular vent is adequate
    - If you will be installing vinyl siding on the home there are gable vents framed with j-channel that should be used
    - Cut holes for the vent in the siding/sheathing
    - Caulk around the edge of the opening to create a seal when the vent is installed
    - Screw the vent into place with exterior wood screws

## **Exhaust Vents** (See Diagram 8)

- Ridge Vents
  - Ridge venting is typically a part of roof covering (metal roofing ridge allows for venting and a ridge vent can be installed with shingles, but not all shingle roofs have ridge venting)
  - Decking should be cut back 2" from the true ridge to allow for air movement (See Diagram 5)
  - If ridge is adequately vented and new roofing is being installed, whirlybird/turbine and mushroom vents may be removed from the roof
- Whirlybird/Turbine Vents
  - These vents spin as hot air flows out of the attic
  - These vents should not be installed new, but they may be found on older homes
  - If ridge venting is installed along with new roofing, decking should be patched and these vents can be removed
  - These vents are generally more expensive
- Mushroom Vents
  - Allow air to flow from the attic, while capped to keep moisture out
  - These vents can be installed if ridge venting is not available
    - A hole should be cut in the decking the size of the hole in the vent
    - Install the vent with the flange over the lower course of roofing and under the upper course to allow water to shed
    - Apply roofing tar on the bottom of the flange and tack the vent into place with roofing nails, cover nail heads with tar

# Tin Roofing

## Safety

- Wear gloves when working with or moving metal, edges are extremely sharp
- If cutting metal with a saw or grinder wear eye protection, hearing protection, and gloves
- Use caution when passing panels of metal up to the roof, make sure there are enough hands to pass and receive
- Sunglasses/hat can help reduce glare from tin on a bright day and increase visibility
- Wear shoes with a good grip, tennis shoes may be a better choice than boots
- If the ground is muddy, avoid shoes getting muddy or bring a pair to swap into because mud on the roof can make the working surface slippery
- If the roof surface gets gritty or shingle debris makes the roof slippery, sweep it off well with a push broom
- Do not walk on materials (tin or synthetic underlayment) that are not fastened down, they can slip easily
- Use caution when working on the ground below roof work, wear hard hats if working in these areas for an extended period of time
- Use ladder safety from page 9

## Tin Roof Project Planning

- What is the pitch of the roof/gable height of the roof (do not work on roof greater pitch than 4:12 or gable height 20' without approval)
- Order tin well in advance and include trim pieces and screws in the order
- Most tin manufacturers will cut tin to right dimension if adequate drawing is provided
- Can the tin overlay the existing roof covering? Will purlins and/or underlayment be needed?
- How many ladders will be needed on site?
- Where is the safest place to get on and off the roof?
- How many vents/obstacles will you have to work around?
- Where will tin be stored? Should be kept out of sight so that it is not stolen
- Can the tin be delivered directly to the jobsite?

## Measurements Needed

- Panels of tin should sit 2" below the true ridge and overhang 2" at the eave
- Length of each surface of roof, panels are 3' wide
- Are there any vents in the roof where tin will cannot be slid over the top of the vent?
  - If so a piece will be measured from 2" below the eave to 12" past the pipe and another piece that runs from 2" below the ridge to 12" below the pipe
- Length needed for any trim piece (valley, transition, rake, ridge, etc.)
- Square footage of roof for synthetic underlayment

## **Quality Control**

- Installation order
  - Drip edge
  - Ice and water shield (in valley, if applicable)
  - Underlayment (if roof is decked solid) or purlins
  - Valley pieces
  - Sheets of tin
  - Rake trim
  - Ridge cap
- Make sure that neoprene screw heads are properly driven
- Check screw pattern:
  - Screws should only be placed into the flat sections of the roof
- Is the overlap of the tin correct?
  - The edge with the smaller rib should be towards the starting gable side with the edge that has the larger rib and tab should be towards the field
  - Small rib overlaps large rib
- Make sure tin is set 2" below the ridge and there is a 2" overhang at the eave
- Make sure that the first piece of tin is square to ridge/string set 2" below ridge
- Make sure all screws are going into wood below the tin
- Make sure that where rake and valley trim need to overlap that the bottom section is installed first

## **Common Mistakes**

- Screws installed incorrectly (overdriven, underdriven, or at an angle)
- Screw pattern for eave and ridge used in all of field
- Small rib facing the wrong way and previous pieces are having to be lifted to slide the next piece into place
- Purlins not adequately secured into rafters
- Top of tin starting at true ridge, leaving no overhang over the drip edge
- First piece made square to the rake/edge of roof, not ridge
- Screws missing purlins, and not left in place and caulked

## **After Work is Complete Quality Control Check**

- Are all trim pieces installed and overlapped correctly?
- Double check over screws to make sure none are over or under driven
- Make sure that any screws that missed wood are sealed well



# Tin Roof Installation Instructions

## Roof Preparation

Metal roofing can be installed either over purlins or directly onto decking. If the original roofing material is not going to be removed, purlins should be installed over that original layer so that tin can fasten to the purlins. If purlins are being installed over a solid surface (like an old shingle roof) a synthetic underlayment should be installed before the purlins. If tin is being installed onto purlins that cross rafters and there is no solid surface, synthetic underlayment will not be installed.

- Ice and Water Shield (Only applicable if installing metal directly to decking)
  - Ice and Water Shield should be installed in all valleys before synthetic underlayment
  - This is an adhesive material that comes in a roll
  - Run from the eave to the peak
  - Do not step on this material until backing is removed and it is stuck into place
  - Remove backing and stick piece down, trim excess even with eave and ridge
- Synthetic Underlayment (See Diagram 11)
  - Start at the lower end of the roof
  - Roll out and fasten with staples or roofing nails
  - Start the next row and overlap at least 2", there should be a designated overlap line on the material
  - Work up to the peak of the roof and trim just short of the peak, this will be left open for venting
    - Extra can be left over the ridge temporarily to help keep the roof watertight
  - Valleys
    - Run an additional piece of underlayment in the valley that runs from the eave to the peak (over ice and water shield, if used)
    - When the regular courses intersect with the valley, overlap the valley at least 6"
    - Do not fasten the synthetic underlayment within 6" of the valley on either side
  - **Do not step on the rolled out material until it is fastened down** , it is incredibly slick
  - Be careful moving around and setting tools down on the synthetic underlayment
  - If synthetic underlayment is not available, 30lb felt paper can be used (15lb felt paper should not be used)

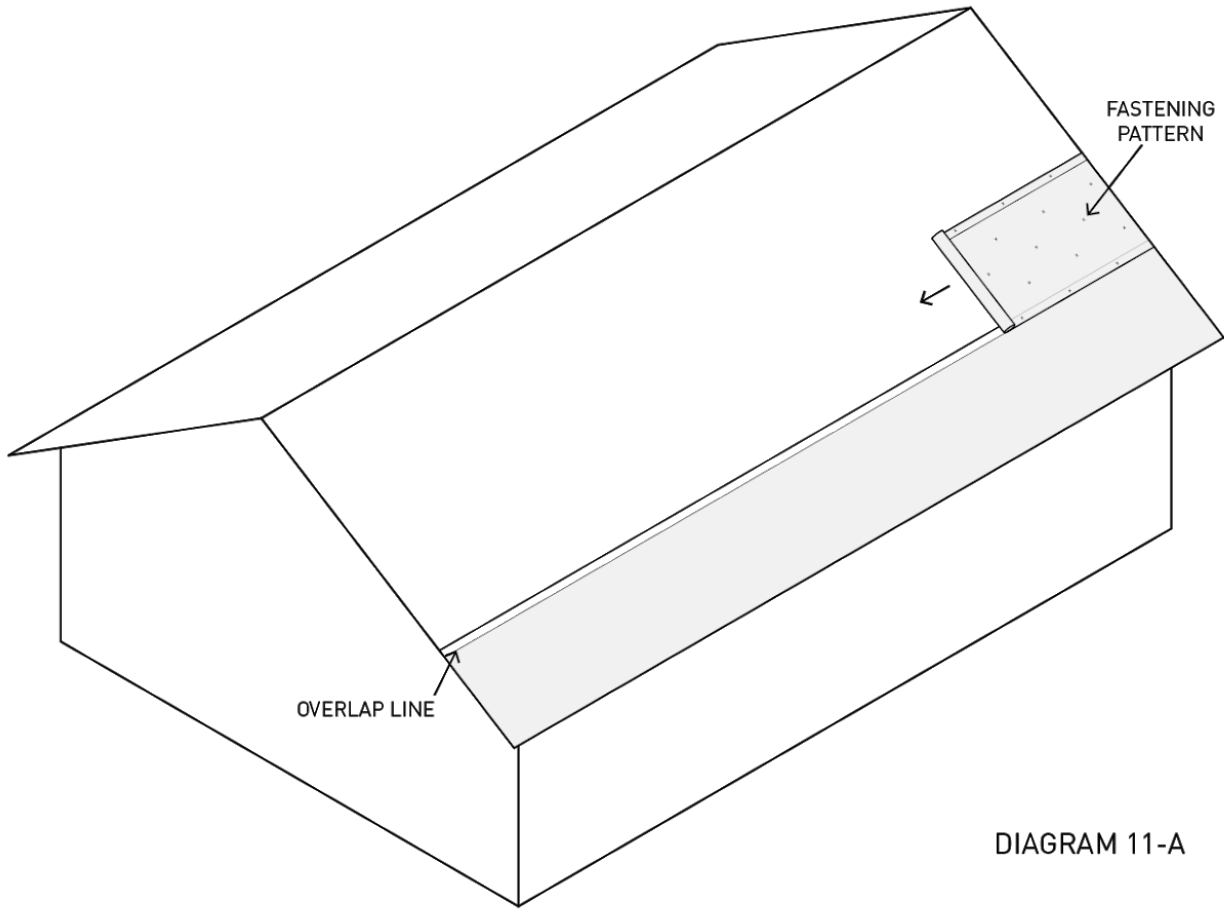

DIAGRAM 11-A

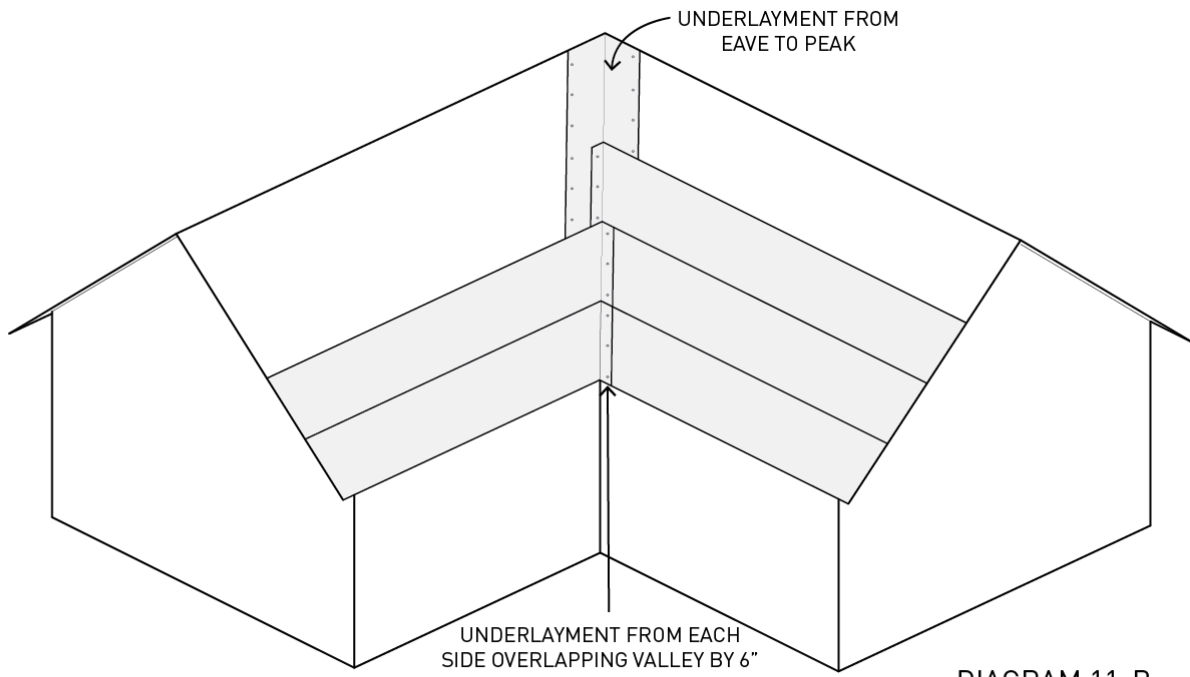
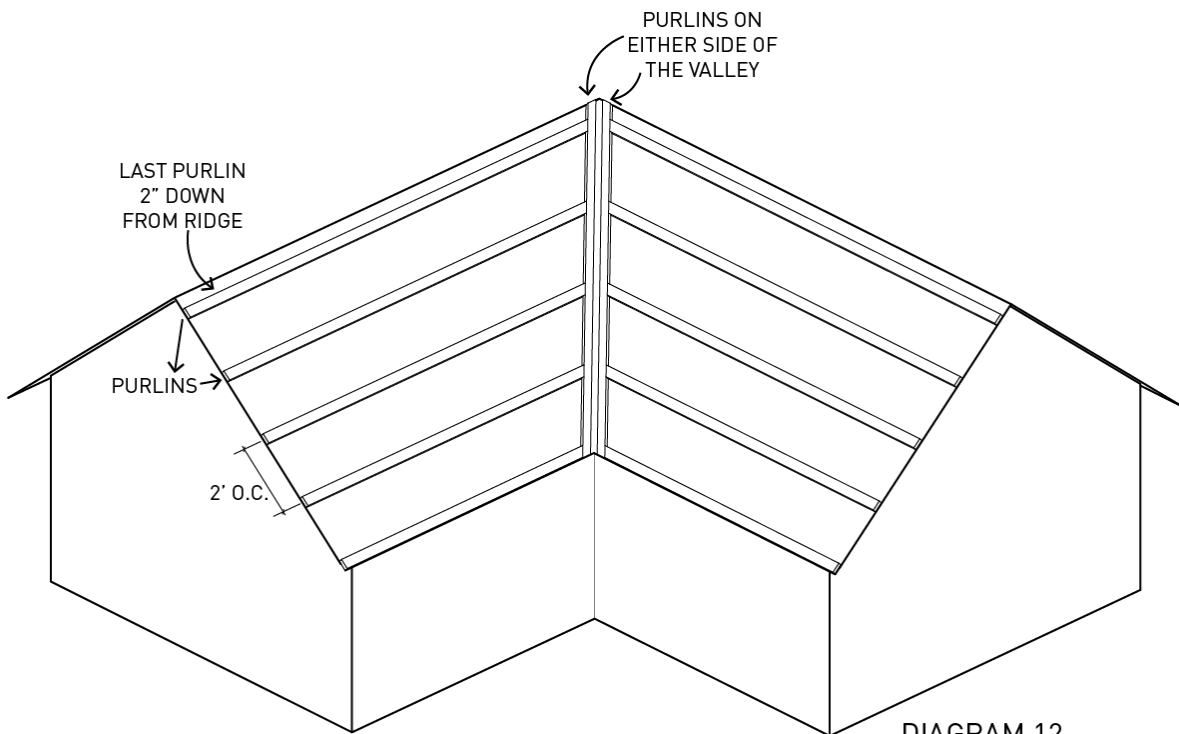

DIAGRAM 11-B

- Purlins (See Diagram 12)
  - Purlins are typically 1x4 material that run perpendicular to the rafters/trusses and act as an attachment surface for metal roofing
  - Whether purlins are installed over bare rafters or over existing roofing, they are installed the same way
    - If installing over existing roofing, **make sure that purlins are being fastened into the rafters**
  - Start at the eave of the roof
  - Fasten purlin into rafter with 3" screws or 16d nails, 2 into each rafter
  - Make sure that ends of purlins land on a rafter, even for an overlay
  - Install the next rows of purlins at 2' on center, working up the roof
    - Rows of purlins should be parallel to one another
  - Install the last row of purlins 2" down from the true ridge of the roof
  - Valleys
    - Install a purlin up either side of the valley, the valley piece of metal will attach directly to these purlins
    - Determine the distance from the valley based on the valley flashing piece (varys among suppliers)
  - Transitions (See Diagram 13)
    - If there is a change of pitch in the roof, install purlins at both sides of that transition
    - There should be two purlins at the bottom of the upper section of roof
      - These will receive the transition flashing when tin is being installed



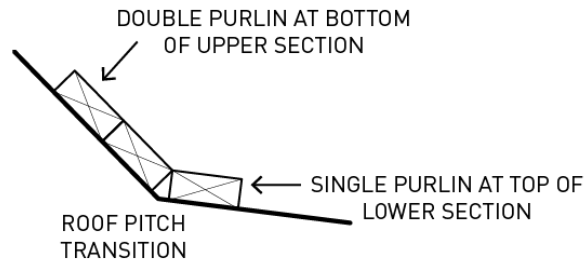

DIAGRAM 13

## Order of operations for metal installation is:

- Drip edge
- Valley pieces
- Sheets of tin
  - Lower courses of tin
  - Transition flashing
  - Rake trim for lower courses
  - Upper courses of tin
- Rake trim
- Ridge cap

### **Drip Edge** (Sometimes called gutter flashing or gutter apron)

- Drip edge will only be installed only on eave edges for metal roofing
- If there are no purlins, drip edge should be tucked underneath synthetic underlayment (See Diagram 14A)
- If there are purlins, drip edge should be installed on top of the purlins that run along the eave (See Diagram 14B)
- Fasten drip edge with roofing nails every 12"
- Overlap pieces by 2"-4"

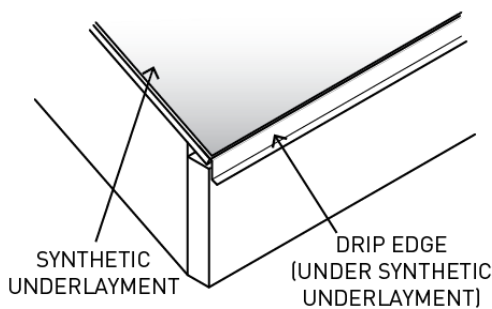

DIAGRAM 14-A

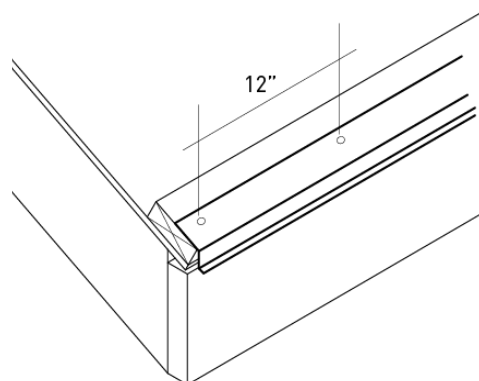

DIAGRAM 14-B

## Valley Flashing (See Diagram 15)

- Run pieces from eave to ridge
  - Lower pieces will be under higher pieces
- Use tin snips to trim the bottom of the piece to match the edge of the eave, and trim the top to match the ridge
- Allow valley to overhang the drip edge by 1"
- If overlap is needed, overlap by minimum of 6"
- Attach every 12" at the very edge of the valley using roofing nails

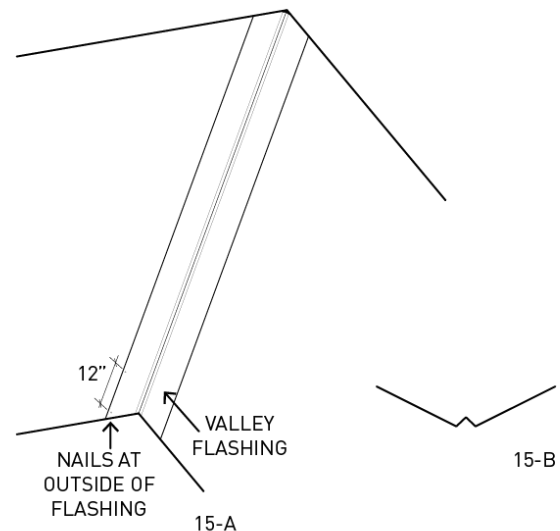
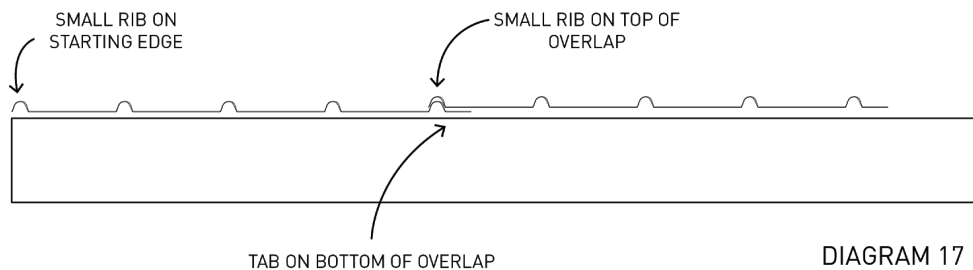
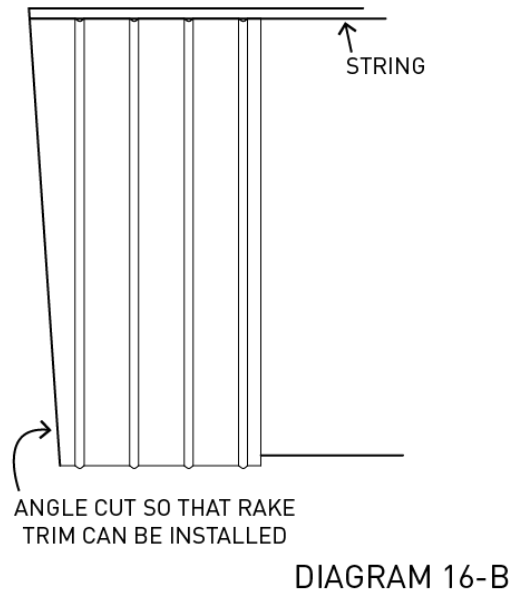
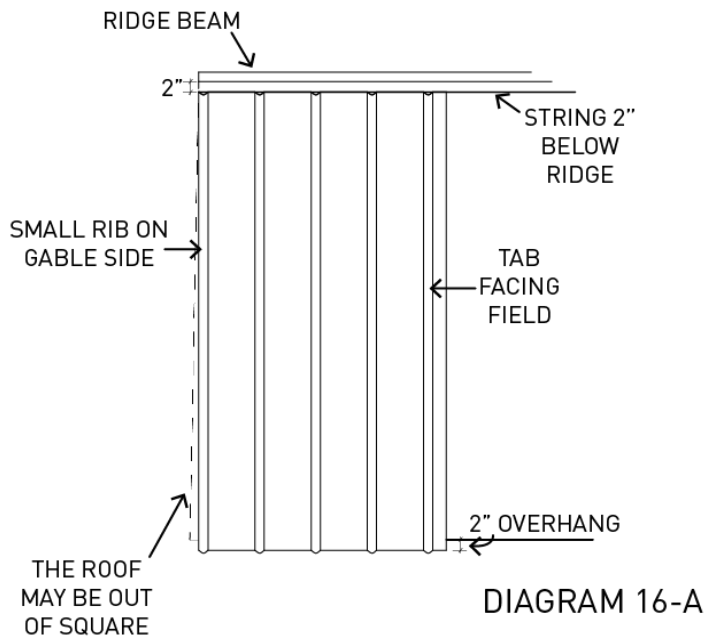

DIAGRAM 15

## Metal Panel Installation

- Cutting pieces of tin
  - Metal can be cut with tin snips, electric tin snips, or a grinder with a metal cutting blade
    - When cutting metal make sure that leather gloves, safety glasses, and ear protection are all worn
    - Edges will be extremely sharp and metal will be hot
  - Notches that need to be cut in tin can be cut with tin snips or with a jigsaw with a metal cutting blade
  - Most of the tin should come already cut to length, however in some cases pieces will have to be cut
    - The last piece will likely have to be cut to a narrower width
    - Pieces of tin in valleys will have to be cut
    - Pieces around vents will have to be cut
  - If possible, cut pieces so that the cut edge will be hidden by ridge cap/transition pieces/etc. because the cut edges rust more easily
- Run a string along the top of the roof
  - The string will run 2" below and parallel to the ridge
  - Tie off to temporary nails/screws at each end
  - Make the string tight
  - This marks where the top of the sheets of tin will line up
- Put the first piece of tin in place (See Diagram 16A)
  - The smaller rib will go on the gable side and the larger rib with the tab will face the field (See Diagram 17)
  - Line the top of the piece up with the string, making it square to the ridge

- If the roof is not square:
  - See dashed line in Diagram 16A that shows potential out of square roof
  - Test the rake trim to see if it will cover the first rib of the piece, despite how the roof is out of square
  - If the rake trim fits over the first rib, despite the discrepancy, install the tin where it is
  - If the roof is extremely out of square, this first piece may need to be trimmed at an angle, so that the rake trim can still be installed later (See Diagram 16B)
- Tin should be set 2" below the ridge and overhang the drip edge by 2" (See Diagram 16A)
- Overlap (See Diagram 17)
  - The following pieces of tin will be installed with their smaller rib overlapping the tabbed rib of the previous piece



- Fastening sheets (See Diagram 18 and 19)
  - Holes should be pre-drilled with a  $\frac{1}{8}$ " drill bit
  - Neoprene screws are used to fasten tin (See Diagram 18)
    - **Do not overdrive the screws**, screws are overdriven if the neoprene gasket squishes out from under the screw head and splits, this will cause the gasket to fail and leak
    - **Do not underdrive the screws**, screws are underdriven if there is no change in the shape of the gasket at all
    - Make sure screws go in straight, if they go in at an angle the gasket won't seal properly
    - Neoprene gasket should expand slightly past its original shape

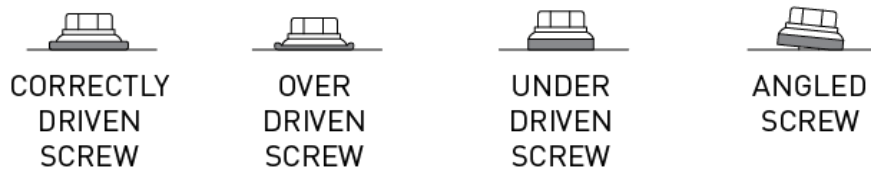

DIAGRAM 18

- Screws will be on the flat surface, about  $\frac{1}{2}$ " from the edge of the rib
- The row of screws along the eave and the row along the ridge will have a different fastening pattern than those in the field
  - For ridge and eave, there will be a screw beside each rib
- The rows of screws in the field:
  - Spacing for rows will be 24", landing on each purlin
  - There will be a screw beside the small rib and the third rib
- The next piece will overlap the first, with the small rib of the second piece over the larger tabbed rib of the first piece

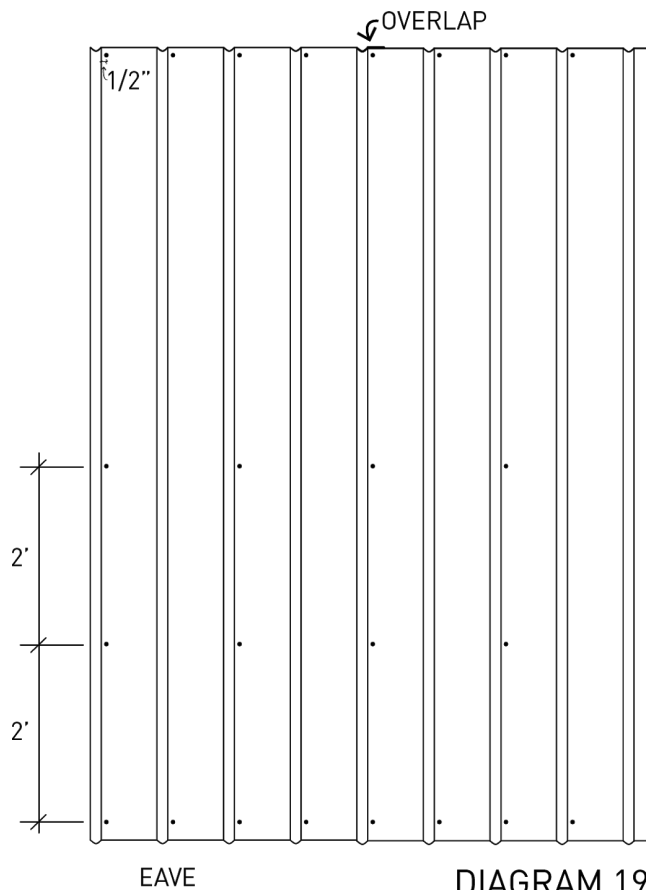

DIAGRAM 19

- Square and fasten pieces in the same manner, working across the roof
- If a screw misses the purlin or if a screw is overdriven and spins in place, leave the screw in place and apply silicone caulk around the screw head
- The last piece of tin on each surface of the roof will have to be cut to the remaining width
  - Measure the piece at both the top and bottom, in case the roof is not square
  - Cut piece to fit on the ground then test for fit
  - Install any fasteners that fit within the regular fastening pattern
  - The edge of this piece will be fastened when the rake trim is installed over top of the metal
- Tin in valleys (See Diagram 20)
  - Pieces of tin that are installed at valleys will have to be cut at an angle
  - Measure from 2" below the ridge (the string line) to 3" from the center of the valley, measure over in the field 3' (width of a piece of tin) and make the measurement again from 2" below the ridge to 3" from the center of the ridge
  - Transfer these measurements onto the piece of tin and cut the angle
  - Fastening along the angle, use the same pattern as is used for the eaves or ridge
    - Screws will go through both the sheet of tin and the valley flashing
    - **Make sure that the screw is going into wood**

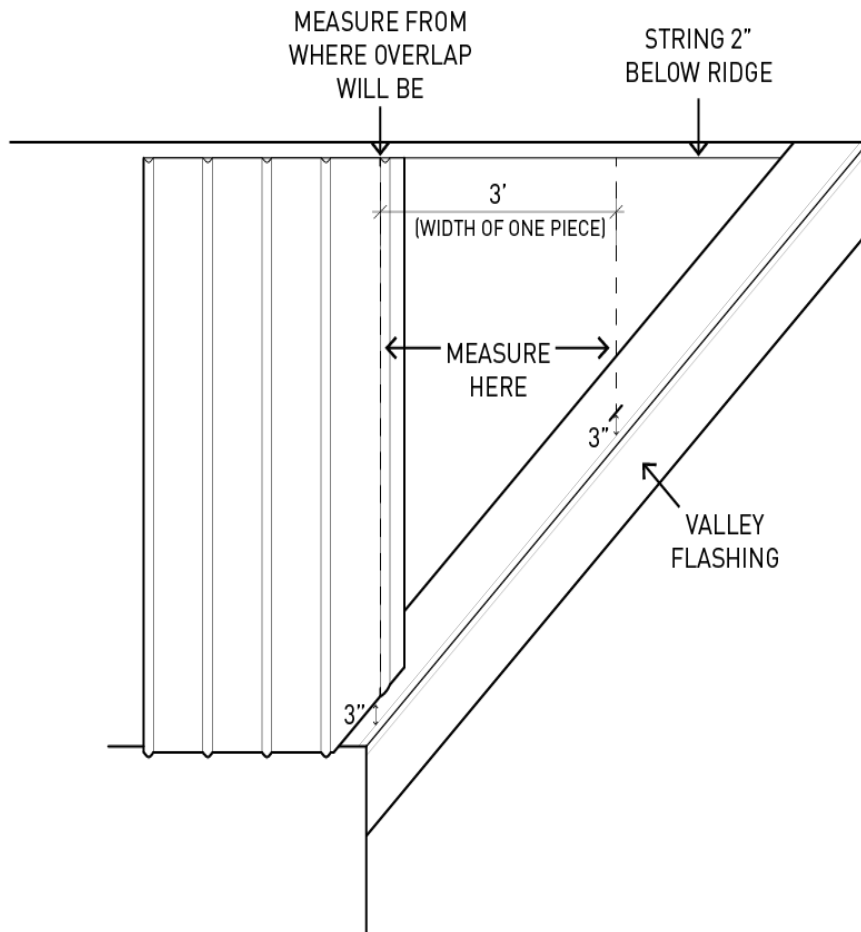

DIAGRAM 20



- Transitions (See Diagram 21)

- If there is a change in the pitch of the roof, install the lower course first
  - Rake trim should also be installed on this lower section before the transition flashing is installed (See instructions below)
- Install the transition flashing piece
  - Along the top of the piece, attach with roofing nails every 12" to purlins
  - Along the bottom put a neoprene screw through the transition piece into each rib of the tin
  - Overlap pieces by 6"
- Install the course of tin above the transition, letting pieces terminate 1" above the bend in the transition piece

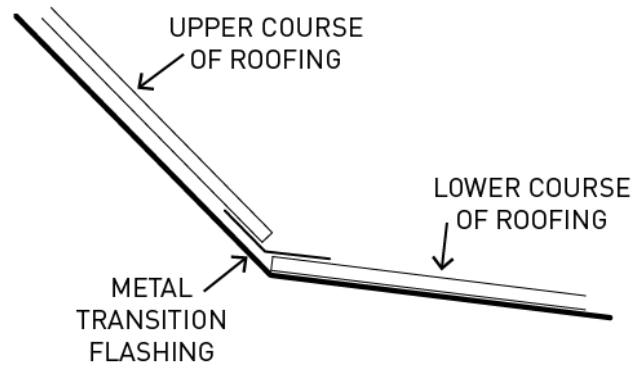

DIAGRAM 21

- Vent Pipes

- If possible, cut a hole in tin so that the piece can be installed over the pipe (See Diagram 22A)
  - Allow, for about 1/2" of space around the pipe
  - Measure and mark where the hole will be in the tin
  - Drill a starting hole and then cut to size with a jigsaw with a metal cutting blade or use a metal cutting hole saw
  - Install boot
    - Make sure the boot is flexible, not rigid so that it can be worked to match the profile of the roofing
    - Apply a generous bead of roof sealant to bottom of boot
    - Install the boot over the pipe and fasten every 2" around the base with neoprene screws
      - Don't work in a circle around the boot, but alternate sides as you install
- If the tin is not able to be lifted over the vent, a two piece system will be used around the pipe (See Diagram 22B)
  - There are boots designed to wrap around a pipe when it cannot be slid over (See Diagram 22C)
  - Cut a "U" the width of the pipe out of the top of the lower piece, allowing the center of the pipe to be 12" into the piece
  - Add purlin support
    - Add a 3' section where the top of the lower piece will land and where the bottom of the upper piece will land
    - This ensures that the lower piece will have something to rest on and that there will be something to fasten the bottom of the upper piece to

- Install the lower piece (leave screws out of the top 2' of this piece as they would interfere with the overlap)
- Install pipe boot
  - Apply a generous bead of roof sealant to the bottom of the boot
  - Attach with a screw in each lower corner for now
- Cut an upside down "U" out of the bottom of the upper piece, allowing the center of the pipe to be 12" into the piece
  - This "U" will be bigger as it is fitting overtop of and around the boot
- Install the upper piece
  - Fasten with the normal fastening pattern
  - Add additional screws at the bottom of the upper piece as you would at the eave
- Fasten around the remainder of the boot with neoprene screws every 2", alternating sides

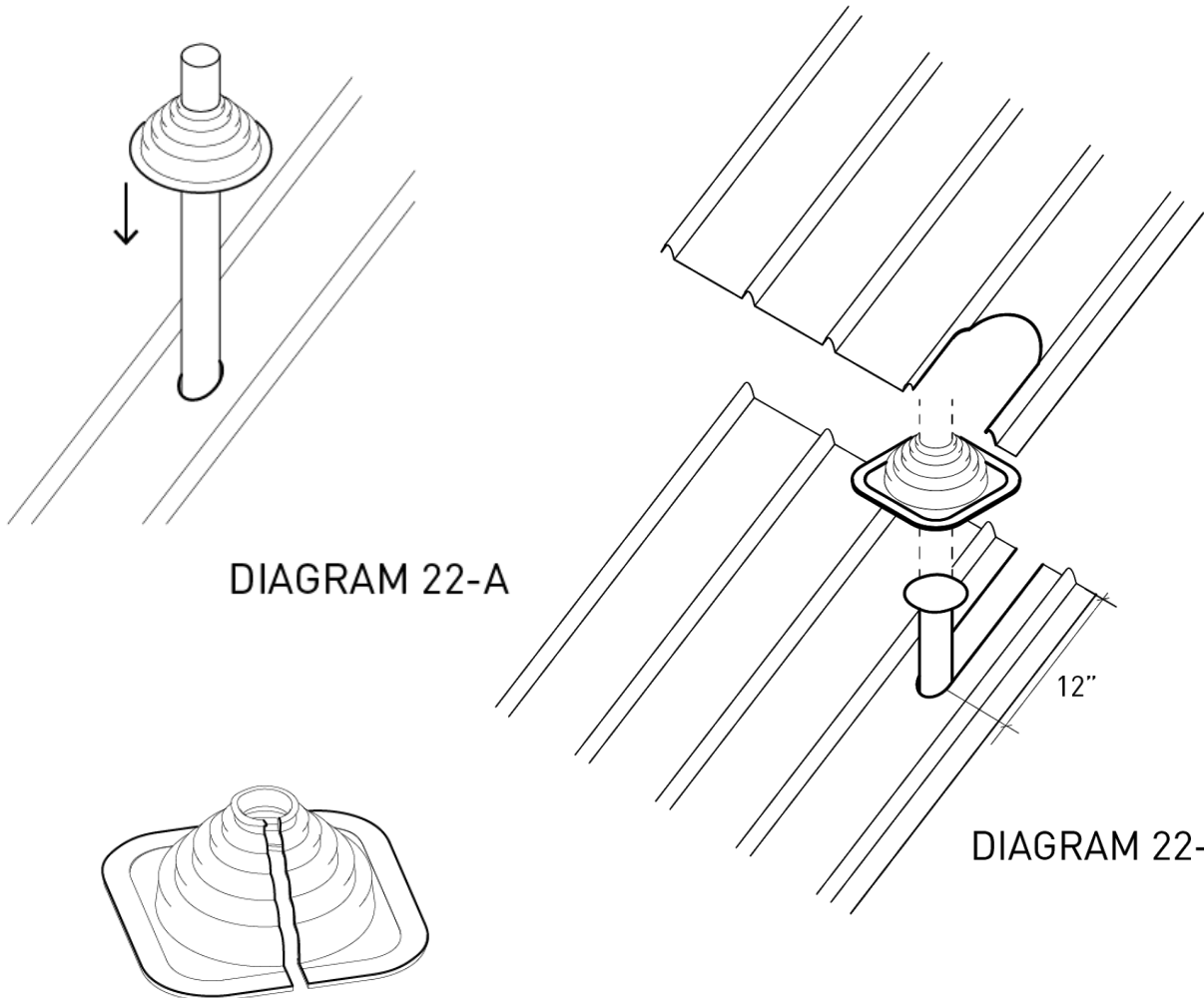

DIAGRAM 22-A

DIAGRAM 22-B

DIAGRAM 22-C

## **Rake Trim** (See Diagram 23)

- Rake trim is installed on the gable sides of the roof and cover the long edges of the tin
- If multiple pieces are needed, start at the eave and work towards the ridge and overlap pieces by 6"
- If rake trim does not overlap a rib in the tin, add a bead of roof sealant on the bottom tab that will rest on the roof before installing
- Fasten through tab with neoprene screws every 24", making sure that screws go into purlins
- Cut pieces plumb at the ridge
- Also fasten into the fascia board through the tab every 24" with neoprene screws

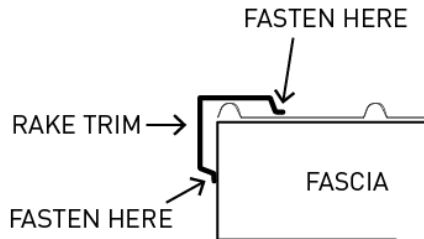

DIAGRAM 23-A

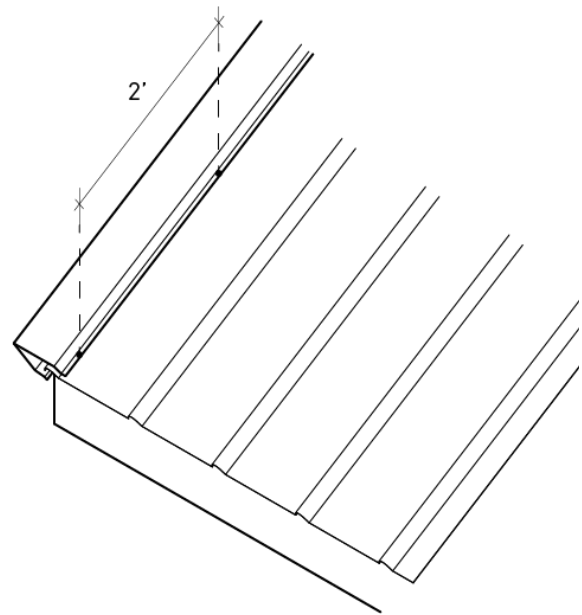

DIAGRAM 23-B

## **Ridge Cap** (See Diagram 24)

- Ridge Cap will be installed to cover ridge of the roof and allow venting
- Fasten with neoprene screws through the tab and into the rib of the sheets of tin
  - Screw into every 3rd rib
- Overlap pieces by 12"
- If the decking runs all the way up to the ridge, it can be cut back 2" on either side to allow air to move

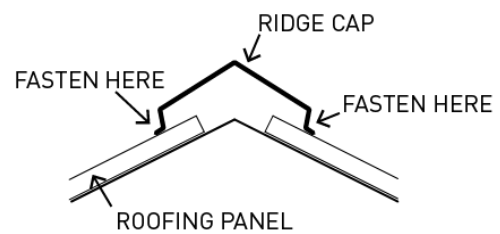

DIAGRAM 24-A

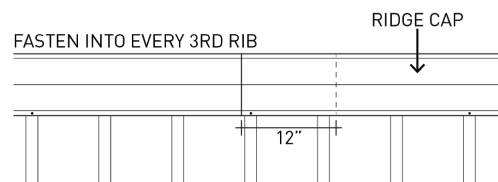
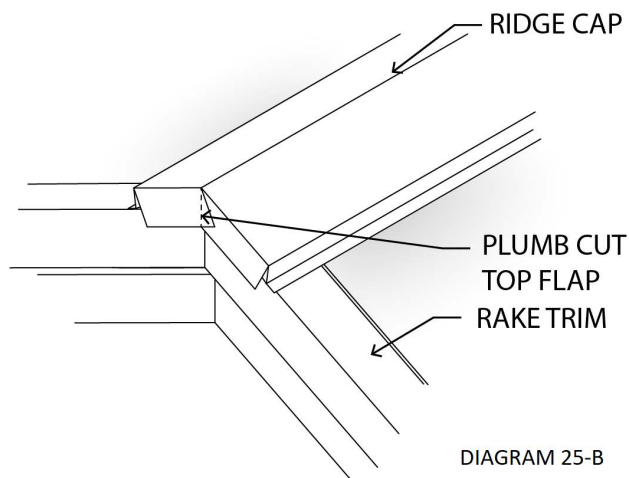
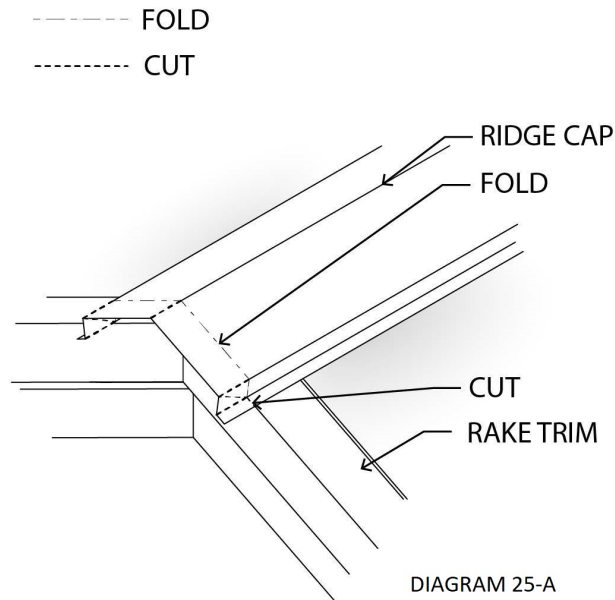

DIAGRAM 24-B

## **Ridge Cap Continued:** (See Diagram 25)

- It is best practice to cut and bend the ridge cap down so that the gap between the ridge cap and rake trim is closed off from weather and critters.
- To do this cut away 2 1/2" of the screw flange and the adjacent corner
- Cut a 2 1/2" slit at the peak of the ridge cap
- This will allow the top of the ridge cap to be bent down and close off the roof nicely.
- Cutting a plumb cut in the outside tab will provide a nice and finished look. (See Diagram 25-B)



## Tin Roofing Material List

| <u>Quantity</u> | <u>Item</u>            | <u>Purpose/Notes</u>                               |
|-----------------|------------------------|--|
|                 | <b>Metal:</b>          |  |
| ___             | -Metal Panels          |  |
| ___             | -Valley Flashing       | If applicable                                      |
| ___             | -Rake Trim             |  |
| ___             | -Ridge Cap             |  |
| ___             | -Transition Flashing   | If applicable                                      |
| ___             | -Drip Edge             |  |
| ___             | Ice and Water Shield   | If applicable                                      |
| ___             | Purlins                | If applicable                                      |
| ___             | Synthetic Underlayment | If applicable, typically sold in 1000 SF rolls     |
|                 | Neoprene Screws        | For fastening metal panels and trim                |
|                 | Roofing Boots          | For all penetrations through the roof              |
|                 | Roofing Nails          | For valley flashing and top of transition flashing |
|                 | Silicone Caulk         | For caulking any screws that miss purlins, etc.    |
|                 | 3" Screws or 16d Nails | For attaching purlins into rafters                 |
|                 | Staples/Roofing Nails  | To attach synthetic underlayment                   |
|                 | 2x6x12 White Wood      | Bearing surface for roof jacks                     |

## Recommended Tools

### Safety:

Glasses  
Gloves  
Ear Plugs  
Hard Hats  
Wasp Spray  
Roof Jacks

### General Tools:

Basic Hand Tools (Tape measures, hammer, pencils, speed square, etc)  
Ladders  
Saw Horses  
Extension Cords/Splitters  
Caulk Gun  
String  
Tin Snips

### Power Tools:

Electric Metal Shears  
Grinder  
→ Metal Blade  
Miter Saw  
Drills/Impact Drivers  
→ T-25 Driver to match deck screws  
→ 1/8" Metal Drill Bits to pre-drill tin  
→ Hex Driver for Neoprenes (typically 1/4" or 5/16")

# SBS Roofing

## Safety

- When working on a mobile home roof, use scraps of ½” OSB to distribute weight and do not stand directly on the mobile home roof
- Use ladder safety from page 9

## SBS Roof Project Planning

- Is the roof safe for volunteers to be working on?
- Will you use a one piece or two piece system?
- Does the home have gutters? Will they need to be removed or can you work with them there?
- Are there any changes in the profile of the roof that will require a change in the layout?
- Is the product being installed on decking or a mobile home roof? (Instructions are different for each)
- For decked roofs
  - Will a synthetic underlayment be needed (required over existing decking, not required on new decking)
  - Is drip edge needed?

## Measurements Needed

- Surface area of the roof (for primer, SBS, synthetic underlayment)
- Perimeter of the roof for the termination bar

## **Quality Control**

- Clean roof of any debris
- Make sure rollers are being used to get rid of any bumps
- Are additional squares of SBS being installed over roof vents with the slit running down the slope of the roof?
- Make sure termination bar is installed with the correct profile – drip edge out
- Make sure that neoprene screws holding termination bar in place are hitting wood/top plate of wall

## **Common Mistakes**

- Roof not swept well before priming
- Nail heads or other obstructions penetrating SBS
- SBS not rolled adequately, material not adhered to roof
- Circle around vent not cut tight enough, large gap left
- Termination bar installed backwards
- Screws holding termination bar not hitting anything solid, just spinning

## **After Work is Complete Quality Control Check**

- Do all vents have an extra square of SBS on them?
- Are all overlaps correct?
- Are termination bars installed correctly?
- Is SBS flat to the surface and adhered well?
- Check that all overlaps of pieces are flat, no bubbles or buckles

# SBS Installation Instructions

SBS is a rubberized, self adhering rolled roofing product designed for flat and low sloping roofs.

## Working with SBS

- There are two different systems for SBS installation on mobile home roofs, the One Piece System and the Two Piece System
  - The one piece system can be slightly more difficult because the size of the pieces
  - Which system is used depends mostly on the comfort level of the volunteers working with the SBS product
- Do not to fold or bend SBS material, that can cause damage to it and make it susceptible to leaking
- When the weather is particularly hot
  - SBS can be difficult to work with as it gets very sticky
  - Do not step on SBS or set things on the SBS while working, this will cause damage to SBS
- Avoid walking on SBS after it is installed
- Be careful when working with and placing SBS, once it is in place it cannot be adjusted
- SBS will only adhere to clean surfaces such as new OSB or a primed metal mobile home roof, SBS will not adhere to any dirty or granulated surfaces such as old decking or tar paper

## SBS on Mobile Homes

Avoid standing directly on the mobile home roof. Pieces of ½" OSB can be used to sit on the roof and work from to distribute the weight. Make sure these pieces span at least 2 of the mobile home trusses. Limit the number of people working on the roof to 2 on each side.

## Preparation

- Sweep the roof clean
- Prime the roof with an oil based primer
  - This creates a clean surface for the SBS to adhere to
  - Most of this painting can be done with rollers from ladders
  - Be cautious not to let primer run down walls of the home
  - Allow to dry overnight before starting SBS installation



## **Build Overhang** (If applicable)

- The purpose of the built out overhang is to prevent water from running down the wall and over windows
- Remove gutters if necessary
  - If these are rigid and hard to remove, they can be cut flush with the wall using a reciprocating saw with a metal cutting blade
- Install a 2x4 around the top edge of the wall (See Diagram 25)
  - Before installing, cut the top of the 2x4 at an angle that will match the line of the roof using a table saw
  - Fasten with 3 1/2" screws into the top plate of the wall or ends of trusses
  - Fasten every 12"-18"
- Install a 1x6 on the outside of the 2x4 (See Diagram 25)
  - Like the 2x4, cut the top of the board at an angle that will match the roof
  - Install with 4" screws into the 2x4
  - Fasten every 12"-18" with one screw over the other
- Short ends of the mobile home:
  - If the roof is flat, continue the 2x4 and 1x6 all the way around the roof
  - If the roof is sloped with a defined ridge, install the 2x4 and 1x6 at those angles
  - If the roof is rounded, cut 2x4 and 1x6 at multiple angles to match as closely as possible to the profile of the roof (See Diagram 26)
  - If there is a built in overhang on the short ends of the mobile home, the 2x4/1x6 do not need to be installed on that side (See Diagram 27)

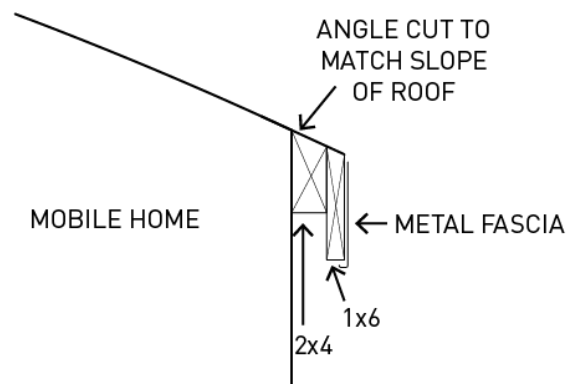

DIAGRAM 25

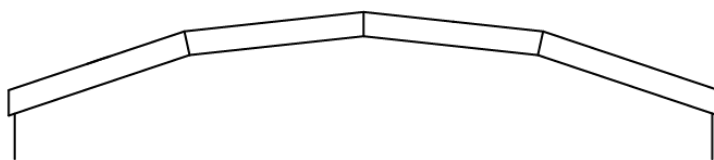

DIAGRAM 26

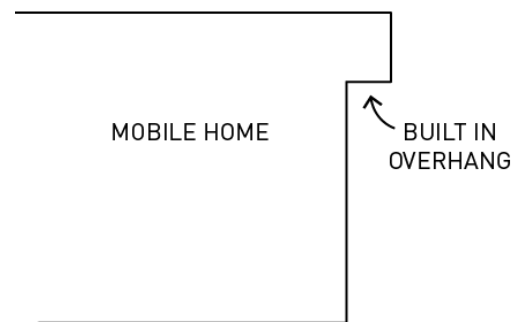

DIAGRAM 27

- Install metal fascia covering over the 1x6 (See Diagram 25)
  - Attach with white aluminum trim nails every 18"-24" one over the other
  - On eaves, start at one side and work towards the other, overlapping pieces 4"
  - **Make tabs and fold around corners to keep water out**

# One Piece System:

## Cut Pieces

- Measure the needed length, pieces will run down the wall 3"-4"
- Pieces can be cut a little long and then trimmed after installation
- Pieces should be cut on the ground using a hook blade
- Pieces can be rolled up and easily carried up to the roof

## Install Pieces (See Diagram 28)

- Position the first piece with the sticky tab facing the field
- Allow 6"-8" to overhang the short side of the mobile home
- Make sure that there is even overhang on each end

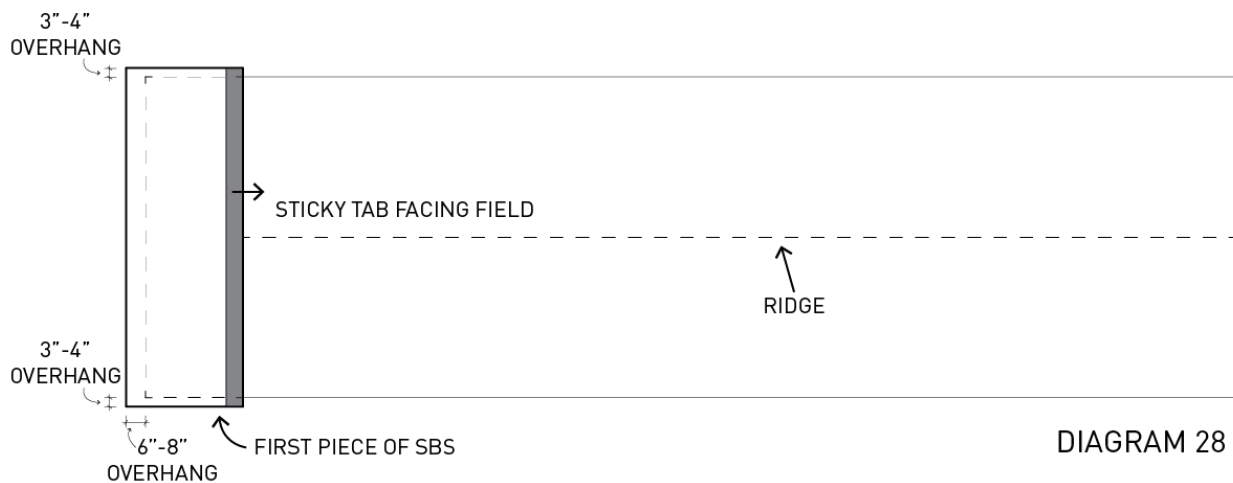

- Stick the first piece down (See Diagram 29)
  - Hold the piece in place on one side of the roof
  - Fold the other half of the piece back, exposing the backing
  - Remove the backing on this half, while still holding the other half in place
  - Let the piece down, working from the peak of the roof towards the eave of the mobile home
  - Then, fold the other half back, remove the backing, and let it down to the roof, working from the peak to the eave
- Using a roller, go over the entire piece applying pressure to help the SBS adhere to the roof
  - Work from the overlap side towards the field
- Get the next piece into position
  - The next piece should cover the sticky tab of the previous piece (See Diagram 30)
  - Do not remove the plastic from the overlap tab on the first piece yet

- Repeat the same process of holding half of the piece, folding back the other half, and removing the backing (See Diagram 29)
- At this point, also remove the plastic from the overlap tab on this half of the roof
- Let the piece down, working from the peak of the roof towards the eave of the mobile home
- Repeat this process on the other side of the roof
- Repeat this process down the length of the roof
- Roll all pieces with roller applying pressure to help pieces adhere
- Follow instructions for vents and termination bar installation listed below

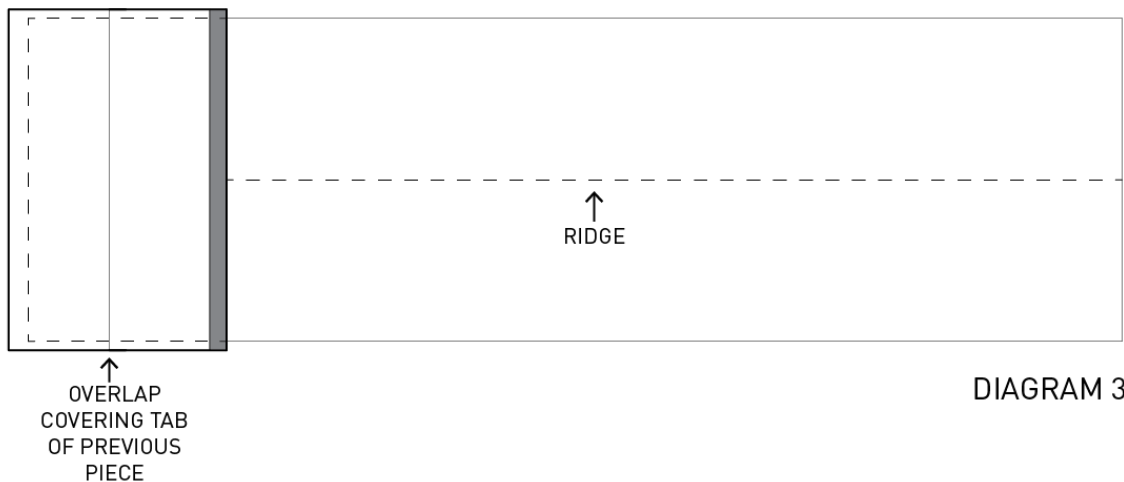
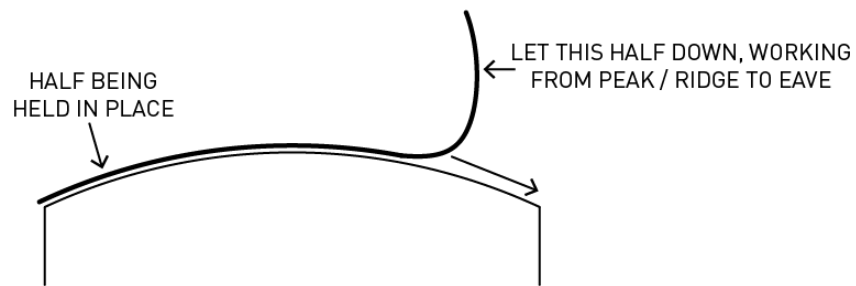
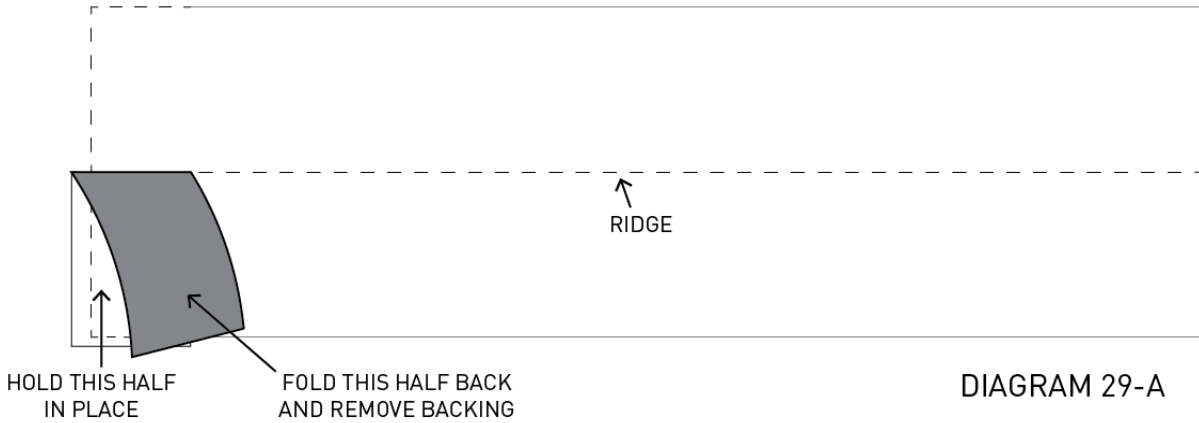

## Two Piece System:

### Cut Pieces

- Pieces will run 3"-4" down the wall and over the ridge 6"
- A chalk line can be snapped to show the ridge
  - This is helpful on rounded roofs where the ridge is not easy to determine
- Pieces can be cut a little long and then trimmed after installation
- Pieces should be cut on the ground using a hook blade
- Pieces can be rolled up and easily carried up to the roof

### Install Pieces (See Diagram 31)

- All pieces on one side of the roof will be on the bottom of the overlap, and should be installed first
- Position the first piece with the sticky tab facing the field
- Allow 6"-8" to overhang the short side of the mobile home
- Make sure that there is 3"-4" of overhang at the eave and that the piece overlaps the ridge 6"

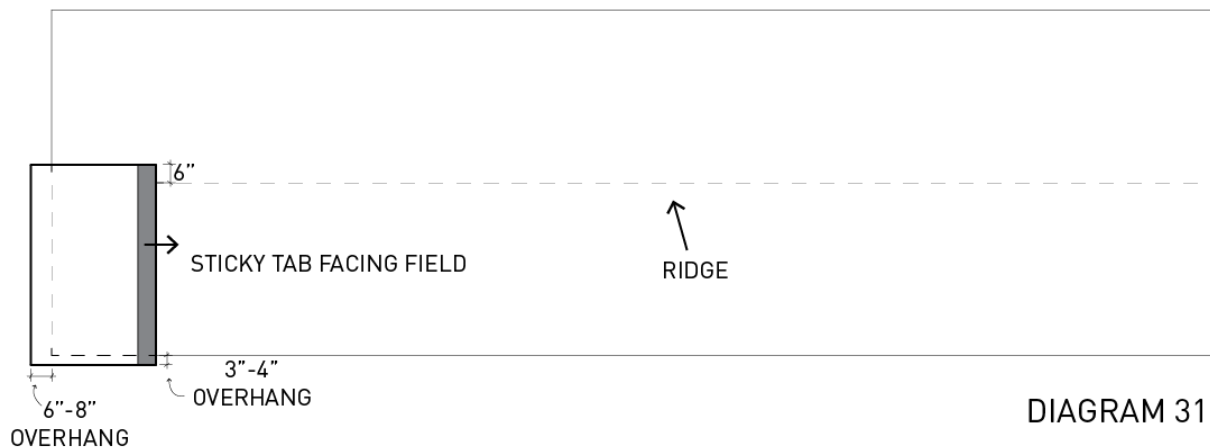

- Stick the first piece down (See Diagram 32)
  - Hold the piece in place on one half (lengthwise)
  - Fold the other half of the piece back, exposing the backing
  - Remove the backing on this half, while still holding the other half in place
  - Let the piece down, working from the middle of the piece to the edge of the piece
  - Then, fold the other half back, remove the backing, and let it down to the roof, working from the middle to the edge

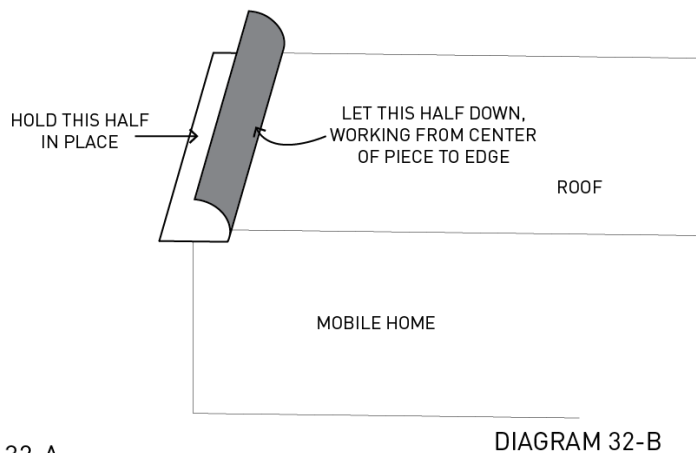
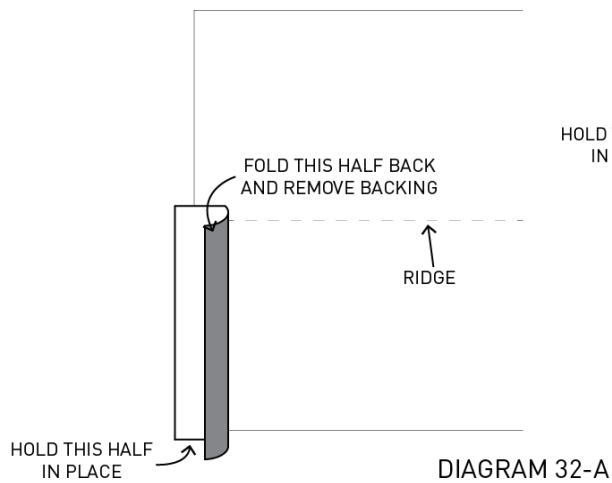

- Using a roller, go over the entire piece applying pressure to help the SBS adhere to the roof, working from overlap side to the field
- Get the next piece into position (on the same side of the roof)
  - The next piece should cover the sticky tab of the previous piece (See Diagram 33)
  - Do not remove the plastic from the overlap tab on the first piece yet
  - Repeat the same process of holding half of the piece, folding back the other half, and removing the backing (See Diagram 32)
  - At this point, also remove the plastic from the overlap tab
  - Let the piece down, working from the middle of the piece to the edge
  - Repeat this process on the other half of the piece

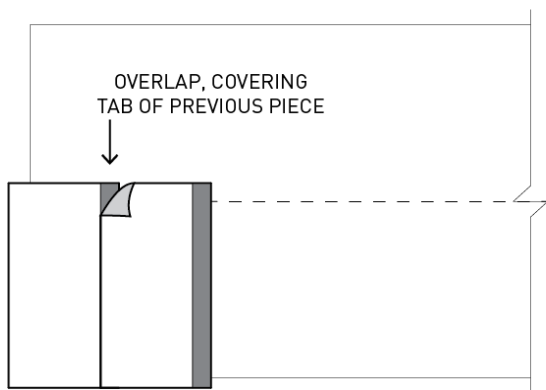

DIAGRAM 33

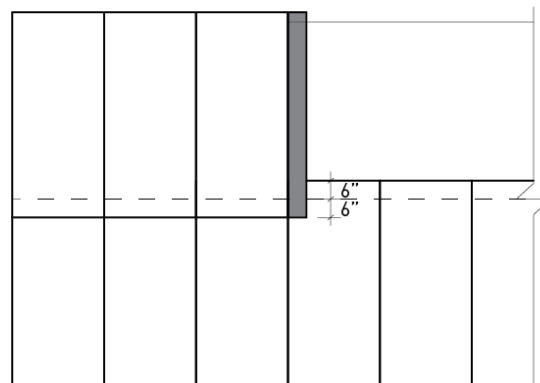

DIAGRAM 34

- Repeat this process down the length of the roof
- Roll all pieces with roller applying pressure to help seal pieces adhere
- The same process will be followed on the other half of the roof (See Diagram 34)
  - Once 3-4 pieces are installed on the first side of the roof, installation can begin on the second side of the roof
- Follow instructions for vents and termination bar installation listed below

## Vent Pipes

- If possible, cut a hole in the SBS so that it can slide down over the vent pipe
  - Add roof tar around the bottom of the vent
  - Install a roofing boot over the vent
    - Apply a generous bead of roofing tar to around the bottom of the vent
    - Install the boot over the pipe and fasten every 2" around the base with neoprene screws
      - Don't work in a circle around the boot, but alternate sides as you install
      - Cover screw heads with roofing tar

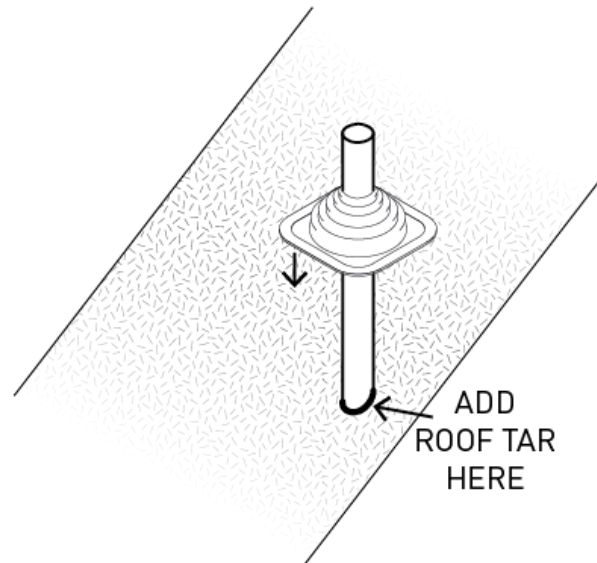
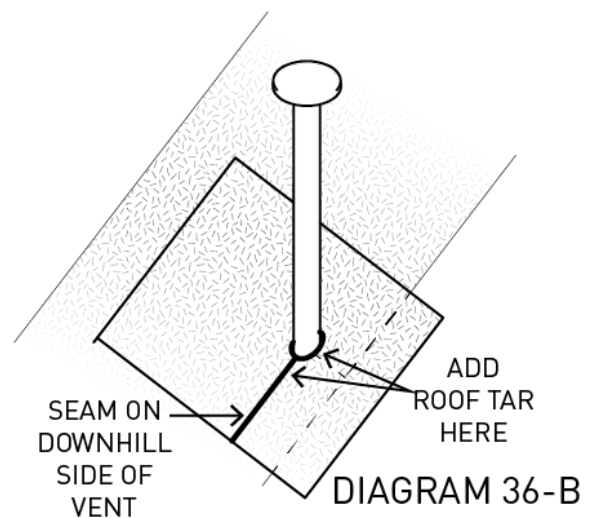
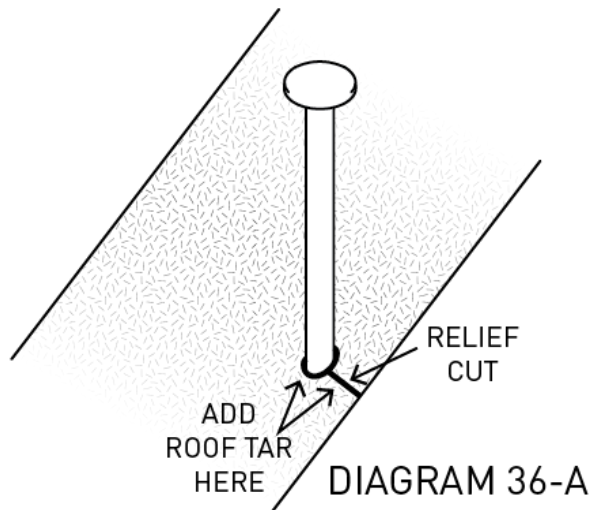

DIAGRAM 35

- If boot cannot slide over the top of the vent pipe, cut the hole in the appropriate place and then cut a relief cut to the closest of the long edges (See Diagram 36)
  - The piece can then be worked around the vent pipe
  - Make sure that the hole is tight (within  $\frac{1}{4}$ " ) around the pipe
  - Dry fit pieces before installing
  - Use scraps or cardboard to make a template if needed
  - After this piece is installed, apply generous bead of roof tar around the vent and along the relief cut
  - If a relief cut was used:
    - Cut a square of SBS that extends past the vent 12" on each side
    - Cut a hole for the vent in the middle of this piece and a relief cut to one edge
    - Dry fit this piece before installing
    - Remove backing and apply a generous bead of roof tar to the perimeter of the sticky side of the patch
    - Put the patch in place around the vent pipe with the relief cut on the downhill side of the pipe
    - Use roller to help piece adhere
    - Apply roof tar around the pipe on top of this square and down the relief cut seam



## Termination Bar

- Termination bar is installed around the top of the mobile home walls to hold down the edges of the SBS
- Mobile home gutters
  - If possible, let SBS terminate into the gutter
  - If not, gutters can be removed or pounded down
- If termination bar comes with a drip edge it should be installed facing out
- Placement of termination bar:
  - If an overhang has been built, the termination bar will be fastened directly into that
  - If no overhang has been built, place termination bar so that screws are going into the top plate of the wall
- Apply a bead of roofing sealant to the back of the termination bar before putting it into place
- Fill every hole with a neoprene screw
  - Be careful not to overdrive screws and strip the wood
- Termination bar can be cut to length using a metal hacksaw
- On the short ends of rounded roof mobile homes, cut smaller sections to match profile (See Diagram 37C)
- Trim the SBS that remains below the termination bar. This should be done soon after the termination bar is installed

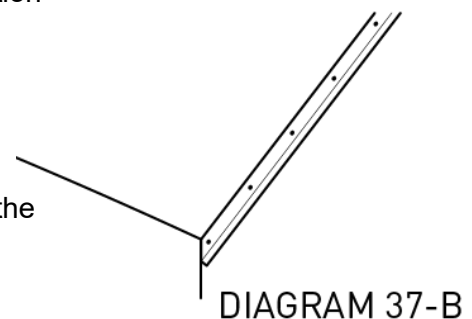
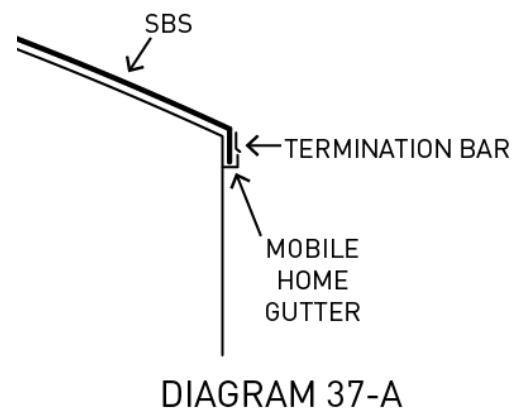

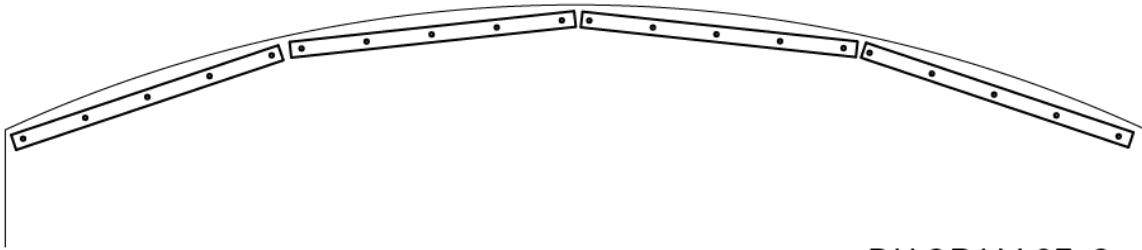

DIAGRAM 37-C

## SBS on Flat or Low Pitched Roofs

SBS can be installed directly over new OSB decking. If SBS is to be installed over old decking, a synthetic underlayment must be installed so that the SBS will adhere to the surface well.

### Synthetic Underlayment (if applicable) (See Diagram 11)

- Drip edge should be installed across the low eave(s) before synthetic underlayment, see instructions below
- If there are valleys in the roof, ice and water shield and a strip of synthetic underlayment should be installed in the valley before synthetic underlayment on the rest of the roof, instructions below in “Valley” section (pg. 125)
- Sweep the roof well before installing synthetic underlayment
- Start at the lower end of the roof
- Roll out and fasten with roofing nails (staples or button caps should not be used because they can damage the SBS material)
  - Fasten with the pattern designated on the material
  - Additionally, fasten every 4”-6” around the perimeter of the underlayment
  - The SBS will adhere to the synthetic underlayment so it is important for that to be fastened well
- Start the next row and overlap at least 2”, there should be a designated overlap line on the material
- Work up to the peak of the roof and trim
- **Do not step on the rolled out material until it is fastened down**, it is incredibly slick
- Be careful moving around and setting tools down on the synthetic underlayment



## Cutting Pieces of SBS

- Pieces will run from one gable edge to the other, even with the drip edge
- Pieces should be cut on the ground using a hook blade
- Pieces can be rolled up and easily carried up to the roof

## Installing Pieces

- Position the first piece with the sticky tab facing up the roof and the other edge even with the drip edge along the eave (See Diagram 38A)
- Install the first piece down (See Diagram 38B)
  - Hold the piece in place along its top half
  - Fold the bottom half of the piece up, exposing the backing
  - Remove the backing on this half, while still holding the upper half in place
  - Let the piece down, working from the middle of the piece towards the eave
  - Then, fold the upper half back, remove the backing, and let it down to the roof, working from the middle of the piece towards the ridge/peak

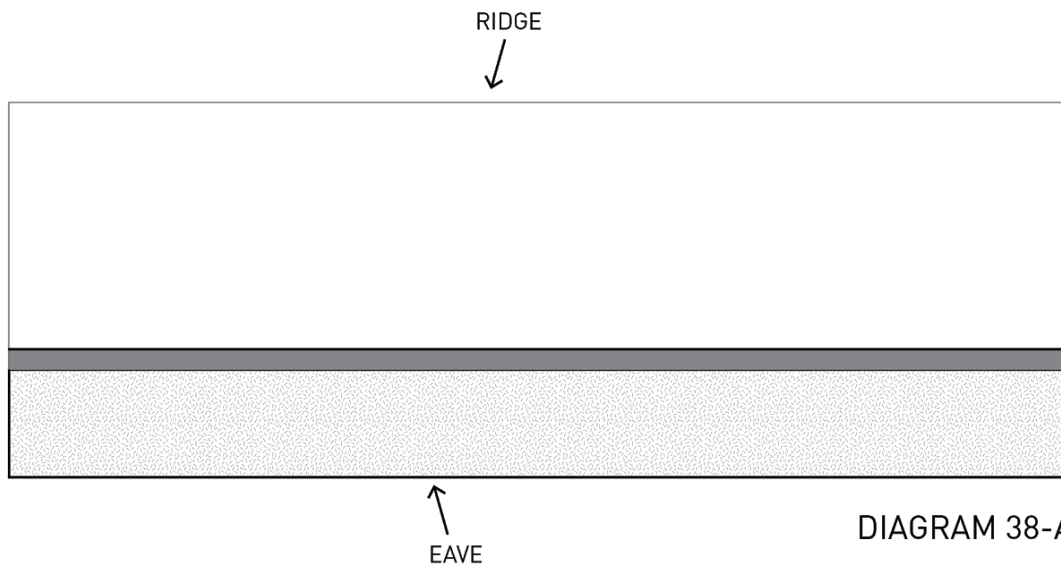

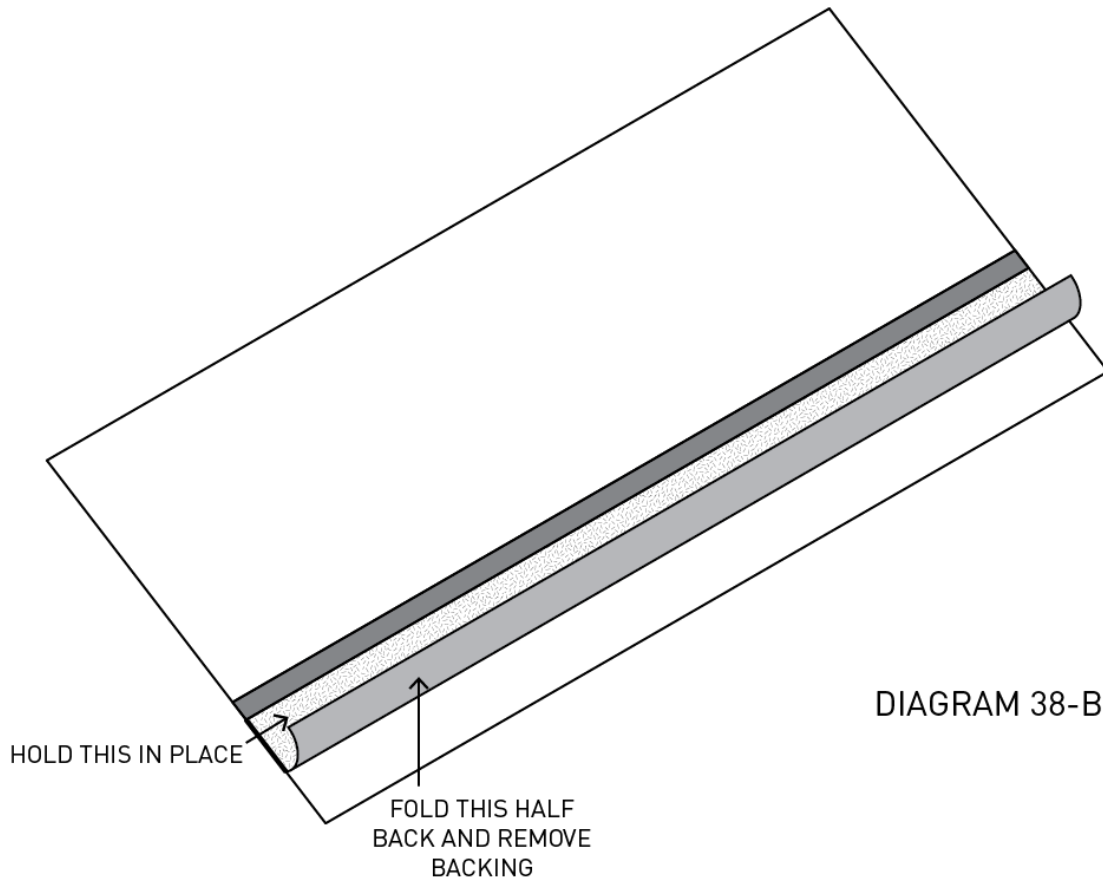

- Using a roller, go over the entire piece applying pressure to help the SBS adhere to the roof, working from eave to ridge
- Get the next piece into position (See Diagram 39)
  - The next piece should cover the sticky tab of the previous piece
  - Do not remove the plastic from the overlap tab on the first piece yet
  - Repeat the same process of holding the upper half of the piece, folding back the lower half, and removing the backing
  - At this point, also remove the plastic from the overlap tab on the lower piece
  - Let the piece down, working from the middle of the piece towards the eave
  - Then, fold the upper half back, remove the backing, and let it down to the roof, working from the middle of the piece towards the ridge/peak

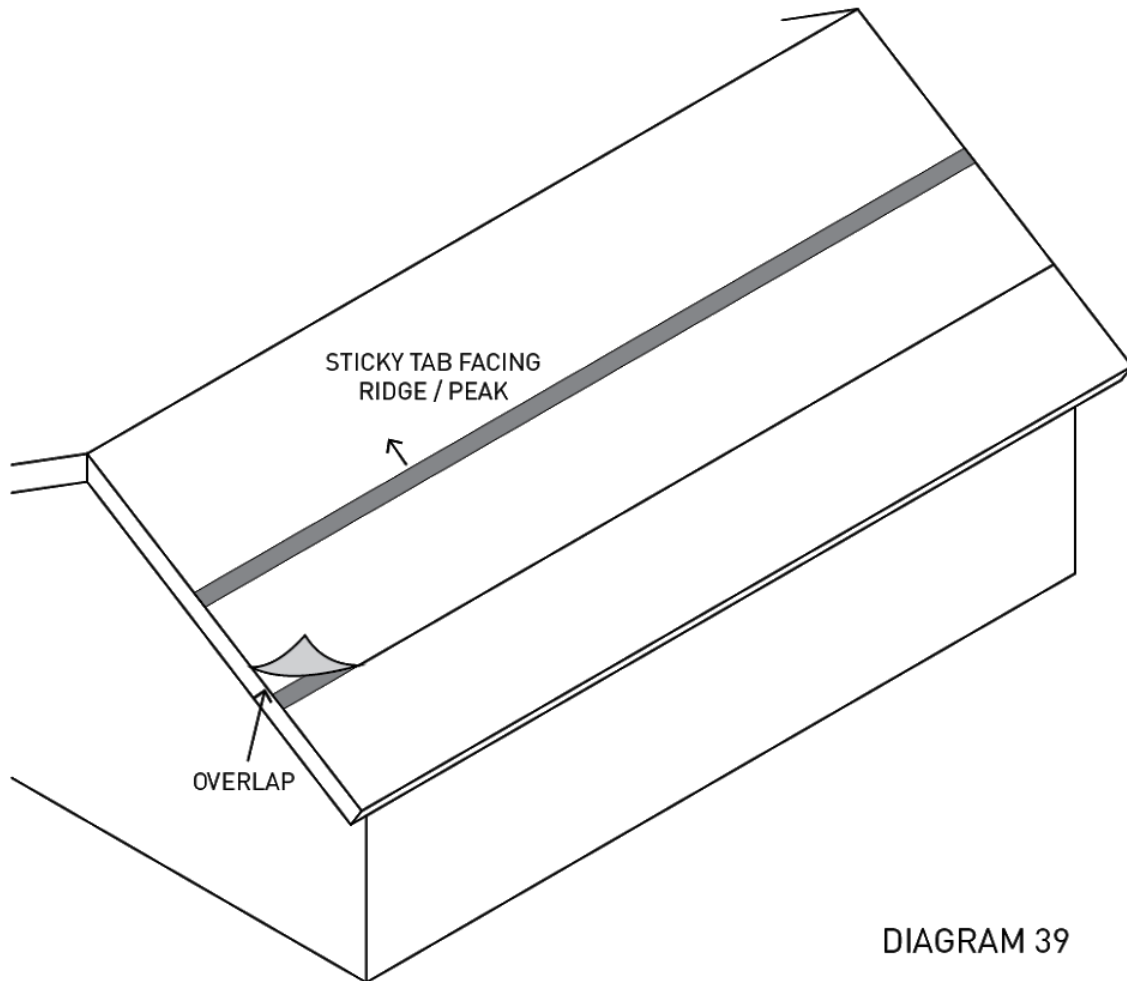
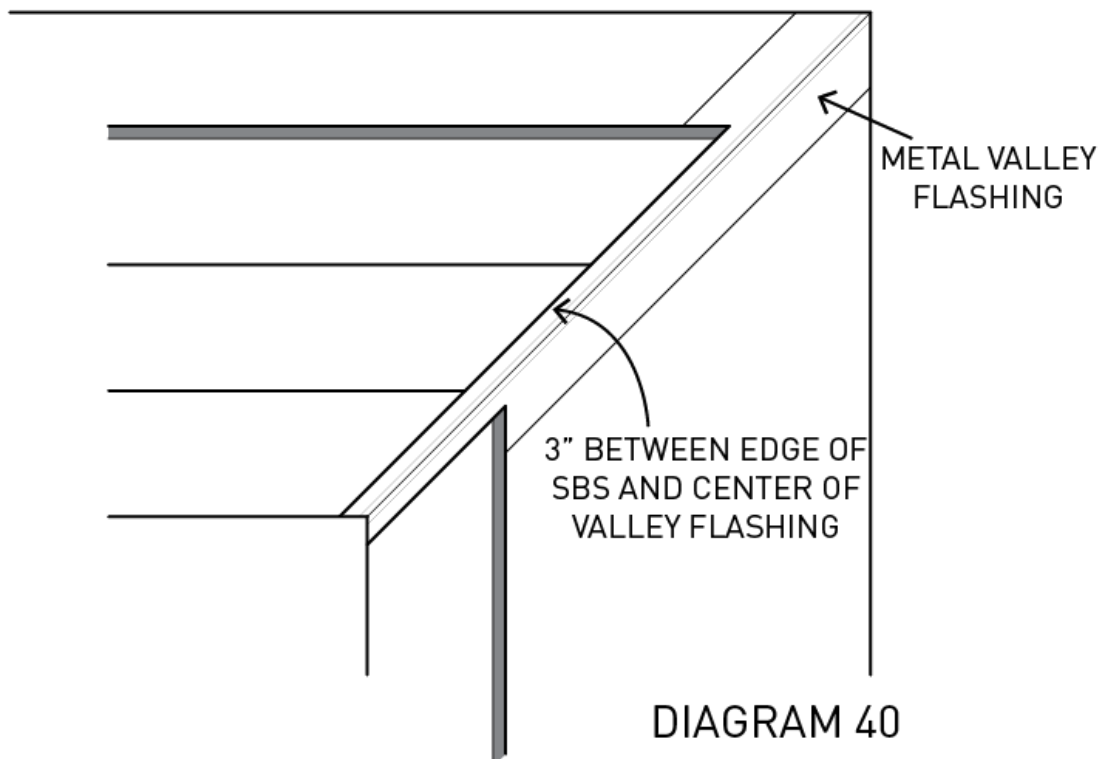

DIAGRAM 39

- Repeat this process until the peak or ridge is reached
- Roll all pieces with roller applying pressure to help pieces adhere, working from eave to ridge
- If the roof is a shed roof, cut the last piece to the remaining width of the roof
- If the roof has a ridge, trim the last piece so that 6" overlaps the ridge and repeat this process for the opposite side of the roof
- Use full length pieces from gable to gable if possible
  - If overlaps must be made, overlap pieces by 12"
  - Add roof tar where edges of top piece will rest on bottom piece

## Valleys

- Install Ice and Water Shield
  - Ice and Water Shield should be installed in all valleys before synthetic underlayment
  - This is an adhesive material that comes in a roll
  - Run from the eave to the peak
  - Do not step on this material until backing is removed and it is stuck into place
  - Remove backing and stick piece down, trim excess even with eave and ridge
- Lay a strip of synthetic underlayment from eave to ridge, fastening only along the long edges using roofing nails (See Diagram 11)
- Synthetic underlayment from each surface of the roof creating the valley should overlap the valley at least 6", do not fasten any closer than 6" from the center of the valley
- Install metal valley flashing (See page 105/Diagram 15)
  - Run pieces from eave to ridge
  - Use tin snips to trim the bottom of the piece to match the edge of the eave, and trim the top to match the ridge
  - Allow valley to overhang the drip edge by 1"
  - If overlap is needed, overlap by minimum of 6"
  - Attach every 12" at the very edge of the valley flashing using roofing nails
- Pieces of SBS terminating in the valley should be trimmed 3" short of the middle of the valley and rolled down well to adhere to the valley flashing (See Diagram 40)



## Vent Pipes

- If possible, cut a hole in the SBS so that it can slide down over the vent pipe (See Diagram 35)
  - Add roofing tar around the vent pipe
  - Install a roofing boot over the vent pipe
    - Apply a generous bead of caulk all the way around the bottom of the boot
    - Install the boot over the pipe and fasten every 2" around the base with neoprene screws
      - Don't work in a circle around the boot, but alternate sides as you install
      - Apply roof tar to each screw head
- If piece cannot slide over the top of the vent pipe, cut the hole in the appropriate place and then cut a relief cut towards the long edge on the upper side of the roof (See Diagram 41)
  - The piece can then be worked around the vent pipe
- Make sure that the hole is tight (within ¼") around the pipe
- Dry fit pieces before installing
- Use scraps or cardboard to make a template if needed
- After this piece is installed, apply generous bead of roof tar around the vent and along the relief cut
- If a relief cut was used:
  - Cut a square of SBS that extends past the vent at least 12" on each side and will cover the entire relief cut
  - Cut a hole for the vent in this piece and a relief cut that will be below the pipe
  - Dry fit this piece before installing
  - Remove backing and apply a generous bead of roof tar to the perimeter of the sticky side of the patch
  - Put the patch in place around the vent pipe with the relief cut below the pipe
  - Roll piece with roller to help it adhere
  - Apply roof tar around the vent on top of this square and down the cut seam

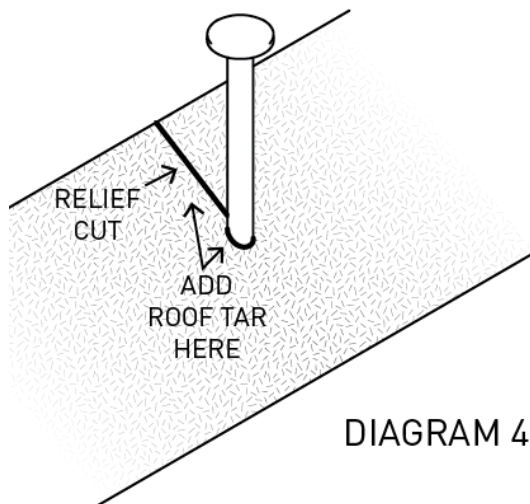

DIAGRAM 41-A

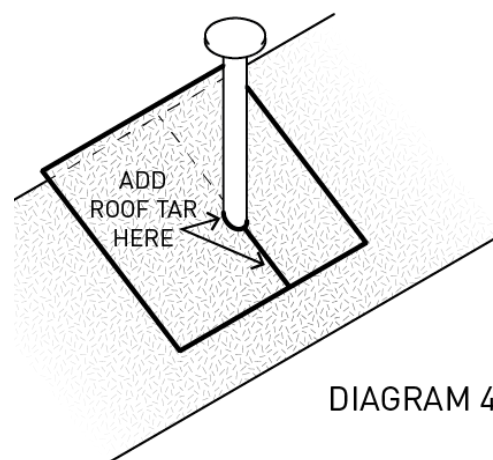

DIAGRAM 41-B

## **SBS Roofing Material List**

| <u>Quantity</u>                            | <u>Item</u>               | <u>Purpose/Notes</u>   |
|--|---------------------------|--|
| <b>Built Out Overhang:</b> (if applicable) |                           |  |
| ___  | 1x6x ___                  | Added overhang around mobile home eave                           |
| ___  | 2x4x ___                  | Added overhang around mobile home eave                           |
| ___  | 3 1/2" or 4" Screws       | To attach overhang   |
| ___  | Metal or Vinyl Fascia     | To go over 1x6   |
| ___  | White Aluminum Trim Nails | To attach fascia   |
| <b>SBS on Mobile Homes:</b>                |                           |  |
| ___  | SBS Roofing               |  |
| ___  | Termination Bar           | To secure edges of mobile home roof                              |
| ___  | Oil Based Primer          | for coating mobile home roofs before SBS is Installed            |
| ___  | Neoprene Screws           | To attach termination bar  |
| ___  | Roofing Tar               |  |
| <b>SBS on Flat or Low Pitched Roof:</b>    |                           |  |
| ___  | SBS Roofing               |  |
| ___  | Ice and Water Shield      | if applicable  |
| ___  | Synthetic Underlayment    | if applicable, typically comes in 1000 SF                        |
| ___  | Valley Flashing           | if applicable  |
| ___  | Roofing Nails             | To attach drip edge, synthetic underlayment, and valley flashing |
| ___  | Roofing Boots             |  |
| ___  | Roofing Sealant           |  |
| ___  | Scrap OSB                 | To work from while on the roof (to distribute weight)            |

## **Recommended Tools**

### **Safety:**

Gloves

### **Painting (mobile home roofs only):**

Rollers

Roller Covers

Roller extension poles

Paint trays

Paint tray liners

Rags

Mineral Spirits - to clean up oil based paint

### **Power Tools:**

Drills/Impact Drivers

→ Hex Drivers for Neoprene Screws (1/4" or 5/16", typically)

→ T-25 Drivers to match deck screws (for building overhang)

Circular Saw (for building overhang)

Table Saw (for building overhang)

### **General Tools:**

Basic Hand Tools (Tape measures, hammer, pencils, speed square, etc)

Ladders

Saw Horses

Caulk Gun

Hack Saw (to cut termination bar)

Utility knives with hook blades





# Soffit and Siding

**Why Siding?** Siding acts as a skin on the outside of the house that helps protect it from water and helps to insulate the home.

**Section Contents:**

|              |     |
|--------------|-----|
| Housewrap    | 136 |
| Vinyl Soffit | 136 |
| Vinyl Siding | 141 |

**Hazardous Siding:**

**Painted** - Any siding painted before 1978 likely contains lead. Do not work on a house containing lead based paint without consulting your construction consultant or Home Repair Coordinator. Lead based paint should not be scraped or sanded under any circumstances.

**Asbestos** - Working with siding containing asbestos can be dangerous. Asbestos siding is most dangerous when cut with a saw or broken into small pieces. Do not do any work on a house with asbestos siding without consulting your construction consultant or Home Repair Coordinator. Vinyl siding cannot be placed over asbestos siding with volunteers.

**Types of Siding:**

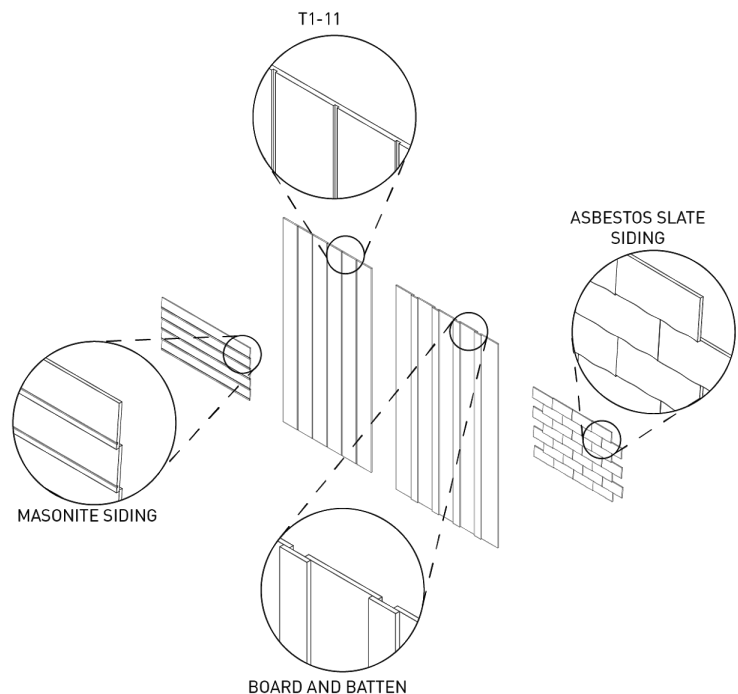

## **Safety**

- Be cautious when removing existing siding (bees/bats/etc. may live behind siding)
- Edges of vinyl can be very sharp, make sure gloves are available
- Make sure ladders are sturdy and secure
- All vinyl should be cut with snips, no power saws should be used

## **Siding Project Planning**

- How many ladders will be needed at a time?
- Is the site safe/friendly for volunteers using ladders?
- How will the siding work with the soffit/how will it finish at the top?
  - If there is not soffit installed on the home, there should be and it should be installed before the vinyl siding
- Is the bottom/starting point for the siding level?
- Will the bottom line of j-channel need to be stepped up or down at all?
- What kind of obstacles will you be working around? Service panel, cable boxes, etc.?
  - Will you need mounting blocks for them?

## **Quality Control**

- Make sure there is house wrap up before siding/soffit
- Make sure the j-channel along the bottom level
- Make sure corner posts installed correctly
- Make sure the overlaps in the siding done correctly with factory edge on the outside
- Make sure seams are overlapped by 1 ½"
- Are the nails too tight/ does the siding have room to expand/contract?
- Make sure pieces of siding are locking together
- Make sure that pieces are fitting into the j-channel/trim
- Make sure seams are staggered

## **Common Mistakes**

- Fastening at j-channel at both ends and working towards the middle, creating waves
- Starting at both sides and working toward the middle, making overlaps not all in the same direction
- Siding just butted together, not overlapping
- Nails too tight or at the edges of nail slots, preventing expansion/contraction
- Not testing that pieces interlock and continuing to install pieces (all above will have to be removed to correct)
- Gaps too big around corners of windows/doors
- Working up instead of across the wall

## Measurements Needed

- Measure perimeter of house and heights of walls (surface area to be sided)
- Measure the width of the overhang (for soffit)
- How many inside/outside corners?
- How many doors/windows? How much j-channel will be needed for each one?

## After Work is Complete Quality Control Check

- Are overlaps done correctly?
- Is siding terminated well at top?
- Are there a few pieces of siding left for homeowners in case of any damage later on?

## Group Leader Tips

- There are a lot of things to remember while working on vinyl siding. Consider copying these reminders and keeping someone in charge of quality control.
  - **Work from one side of the house to the other**
  - **Minimum 1 ½" overlap**
  - **Attach every 12"-18" with roofing nails or lathe screws**
    - **Do not pound nails tight, leave a nickle's width behind them for expansion contraction**
    - **Make sure that nails are in the middle of the nailing slots**
  - **Make sure that pieces are interlocking by tugging out on the bottom of them**
  - **Stagger the seams by a minimum of 2'**
  - **No pieces shorter than 2' should be used (unless the space is smaller than that)**
- Work as an assembly line around the house
  - Once housewrap is installed on one side, volunteers can start cutting and taping, then starting to install vinyl trim (while others continue housewrap)
  - Once all the trim is installed on one wall, the siding can start on that wall and the trim crew can move on to the next wall
- When installing siding or soffit, designate who is cutting and who is installing
  - Have the person installing measure ahead so that whoever is cutting can have the next piece ready
- To cut vinyl, you can kneel on the right side of the cut line with the right knee, as you cut lift up the left side of the cut, this allows more working space for the snips

# House Wrap Instructions

Housewrap is a weather barrier layer installed before siding, intended to protect the walls from moisture.

- Housewrap should be installed with the words facing out, it is designed to weep water out
- Install with staples or button cap nails, attach every 18" - 24"
- Depending on the working area housewrap can be installed two ways
  - Hold the roll up vertically and unroll it along the wall, attaching it as you go
  - Measuring and cutting pieces and then attaching them
    - This sometimes works better when the area is high off the ground and work is being done from ladders
- Make housewrap as flat to the wall as possible, pulling it tight to avoid bubbles
- If multiple courses are needed, install the course on the bottom first, so that when the top piece is installed, water would be flowing to to the outside of the housewrap
- Wherever there is a seam, overlap pieces by 1'-2'
  - All seams should be taped with housewrap tape
  - Lower courses should always be behind upper courses
- Cut house wrap back from windows/doors/etc. 1"-2"
  - Tape around these edges, installing the tape on the bottom first, then the sides, and then across the top
  - Let all pieces of tape extend several inches past the corner of the window
- House wrap can hang down lower than necessary and then can be trimmed after siding is installed

# Vinyl Soffit Instructions

## Bird Boxes/Corners (See Diagram 1)

- The corners of the house may require extra framing before vinyl soffit can be installed
- Determine the slope of the roof. This angle will be transferred onto 2x8 or 2x10 material, depending on the slope of the roof
  - Measure how long this piece will need to be (matching the overhang) and cut it accordingly
- This angled piece will make a corner with a 2x4 or 2x6, (depending on the available space) that will extend to the wall and be attached directly to the wall
- Assemble these two pieces before installing
- Pre-drill through the skinny section of the angle before screwing it up into the fascia board so that it doesn't split
- Install the bird box

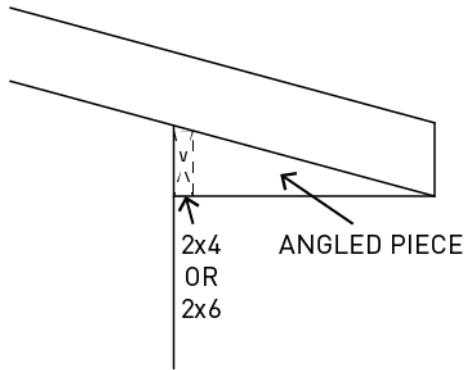

DIAGRAM 1-A

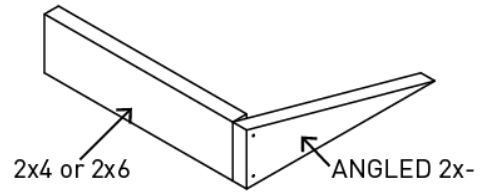

DIAGRAM 1-B

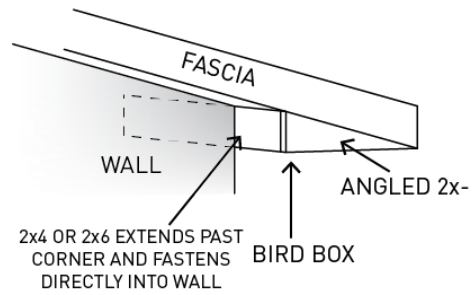

DIAGRAM 1-C

**F-Channel** (Or J-Channel, see second bullet to determine)

- Install f-channel along the wall of the house, with nailing tab down (See Diagram 2A and 2B)
  - The first piece will start at the corner of the house
  - Make sure that the opening of the f-channel is level with the bottom of the fascia board
  - Attach with roofing nails (1 1/4"-2") every 12"
  - Follow the same process for both eave and gable sides of the home (See Diagram 3)
- **If soffit were being installed without vinyl siding, this piece of f-channel should either be installed upside down or replaced with j-channel (attached through the back with short exterior screws) so that the nailing flange does not show after soffit is installed (See Diagram 2C and 2D)**

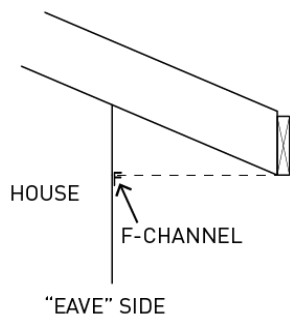

DIAGRAM 2-A

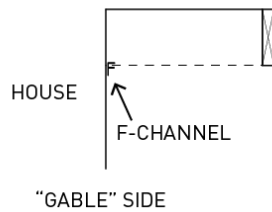

DIAGRAM 2-B

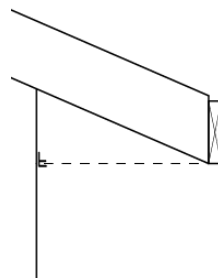

DIAGRAM 2-C

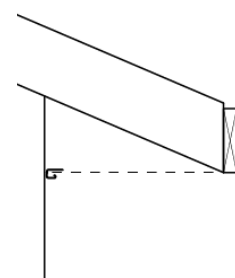

DIAGRAM 2-D

## Install Soffit Pieces

- Determine vented or solid pieces
  - Solid soffit should be used where there is no venting to the attic, generally the gable (angled) sides of the roof
  - Vented soffit should be used where there is venting to the attic, generally the eave (flat) sides of the roof
- Measure from the inside of the f-channel to the outside of the fascia board and subtract ¼" from this measurement
- **Measure each piece individually**, expect fluctuation in measurements of older houses
  - Do not mass produce soffit pieces without measuring first, they may not fit
- Make sure pieces are marked square and cut pieces to length using tin snips (See Diagram 4)
- **Pieces will be cut off of 12' sections of soffit and run perpendicular to the wall, interlocking with one another** (See Diagram 4 and 5)

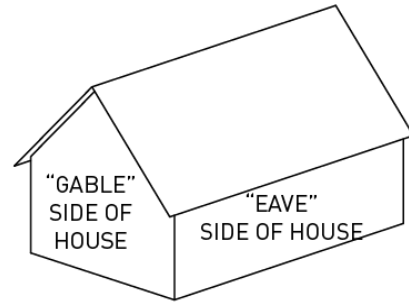

DIAGRAM 3

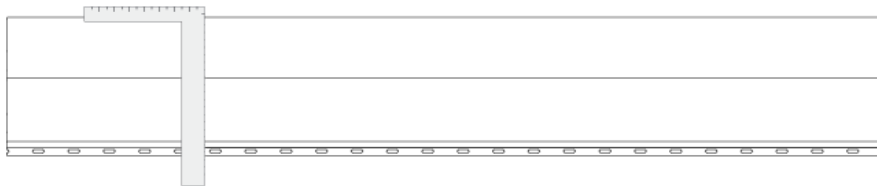

DIAGRAM 4

- The first piece(s): (See Diagram 5)
  - The first piece in a run should be installed with the non-flange side on the starting edge and the nailing flange towards the field
  - On the eave sides the first piece(s) that are below the birdbox will be tacked in with white trim nails in each corner (See Diagram 5A)
  - The first piece on the gable side will require a piece of j-channel to catch the edge that intersects the bird box (See Diagram 5B)

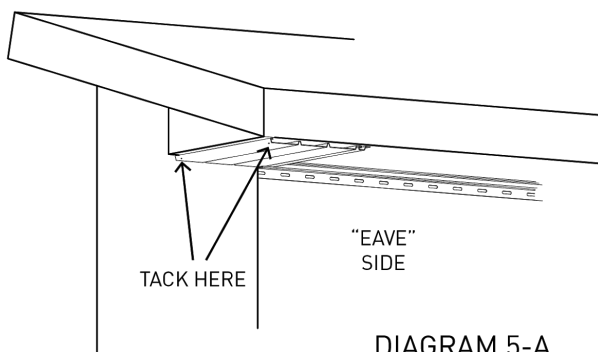

DIAGRAM 5-A

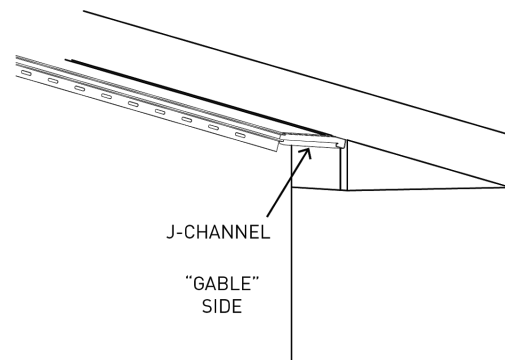
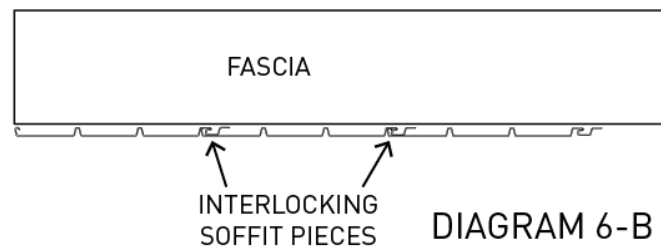
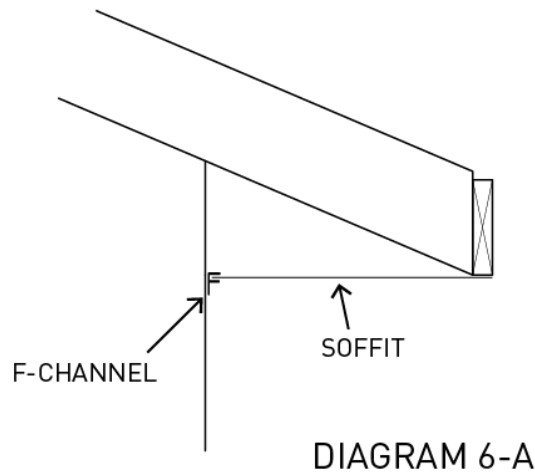
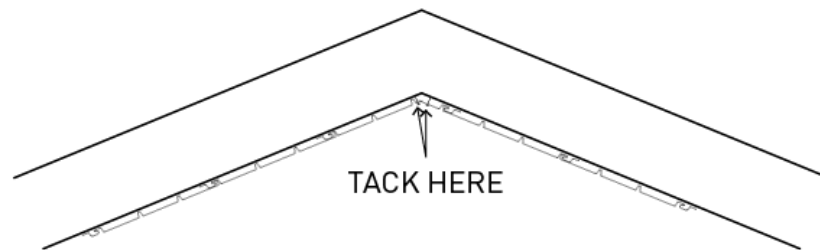

DIAGRAM 5-B

- For the next pieces, insert one end into the f-channel and attach the other (through the nailing flange) with a roofing nail to the bottom of the fascia board (See Diagram 6)
- Snap the next piece of soffit to the first (See Diagram 6B)
  - Fully insert pieces into the f-channel and pull taugth before attaching to the fascia
  - Pieces should not stick out beyond the fascia board



- For gable sides, start at one side and work up to the ridge, at the ridge bend the piece so that it will fit into the f-channel and tack into the fascia board with white trim nails on both sides of the ridge to help hold its shape, continue working down the other side and have the last piece terminate into a piece of j-channel (See Diagram 7)



## Metal Fascia

- Metal fascia should fit snug underneath the soffit pieces to hold them in place and slide underneath the drip edge (See Diagram 8A)
- Attach with white aluminum trim nails every 18"-24" one over the other
  - Make sure lower nails are high enough to go into wood
- On eaves, start at one side and work towards the other, overlapping pieces about 4"
- On gables, start at the bottom on both sides and work towards the ridge, overlapping pieces at the ridge
  - The piece on the top of the ridge overlap should be cut plumb
- Make tabs for corners to keep water out (See Diagram 8B)

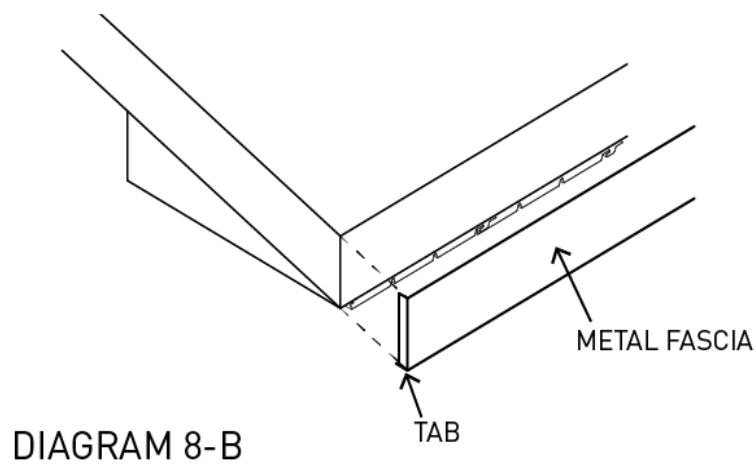
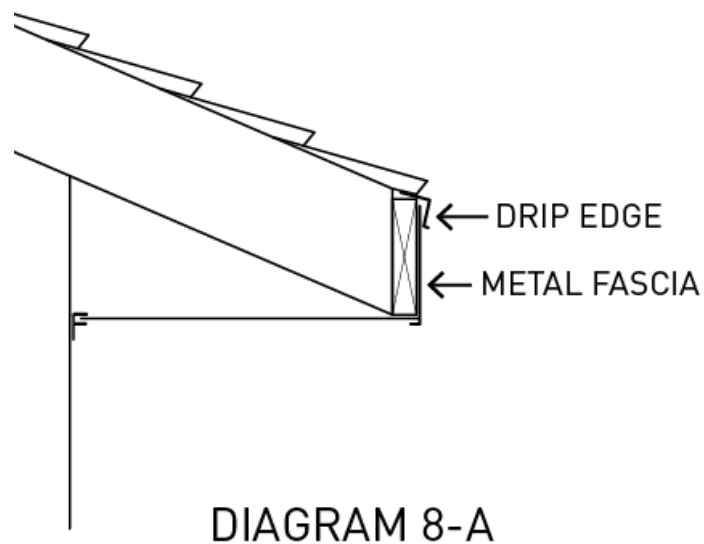



# Vinyl Siding Instructions

- Housewrap and vinyl soffit should both be installed before vinyl siding
- Corner posts and J-channel trim will be installed before siding to hold the edges of the siding

## Vinyl Trim

- It is good practice to install all trim in one area before starting to install siding
- Corner posts should be installed before J-channel at the base/top of the wall
- Corner Posts
  - There are specific pieces for outside corners (See Diagram 9) and inside corners (See Diagram 10)
    - Butt corner piece up to soffit and allow to run down 3" below the starting line for the siding
  - Attach corner piece with roofing nails or lathe screws (1 ¼" - 2") through the nailing flange every 12"-18"

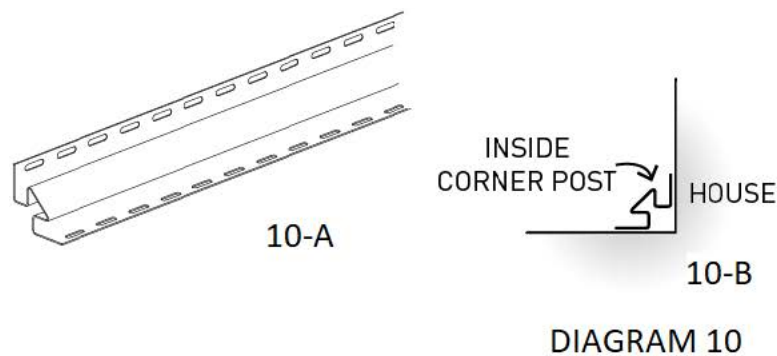
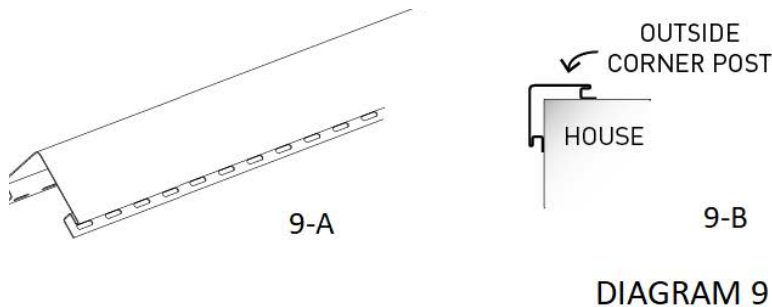

## J-channel Basics:

- To cut J-channel, snip the front and back using tin snips, bend the piece in order to be able to cut the middle (See Diagram 11)
- All J-channel should be installed with roofing nails or lathe screws every 8"-12"
- **Butt Joint** (See Diagram 12), is used to join pieces of J-Channel together for long runs. A tab on the front face of the J-Channel is slid behind the front of the adjacent piece of J-channel.

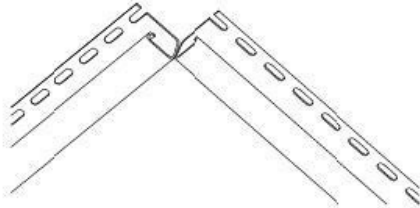

DIAGRAM 11

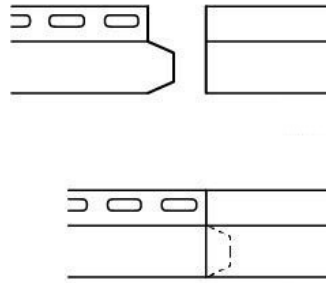

DIAGRAM 12

**Top Outside Corner** (See Diagram 13), are used at the top corner of doors, windows, and other obstacles on the wall.

- **For the top piece of J-channel**
  - Cut a piece of J-channel the width of the window frame + twice the width of the front of J-channel that is being used. This can vary depending on J-channel. Typically your cut will be 1 1/2" to 2" wider than the window frame.
  - Mark and cut a line at 45° from the top outside corners. This cut will create the false miter. (See Diagram 13-A)
  - Cut a slit in the bottom of the J-channel adjacent to the back. Bend the tab created down 90°. This tab will tuck into side J-Channel (See Diagram 13-B and 13-C)
  - Install piece loosely until all pieces are installed

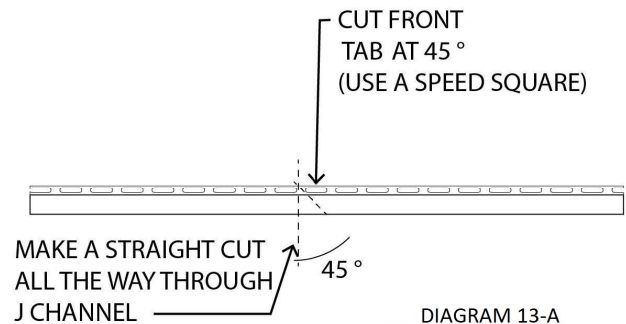

DIAGRAM 13-A

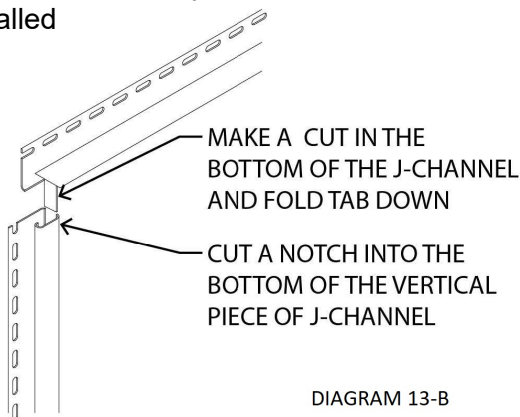

DIAGRAM 13-B

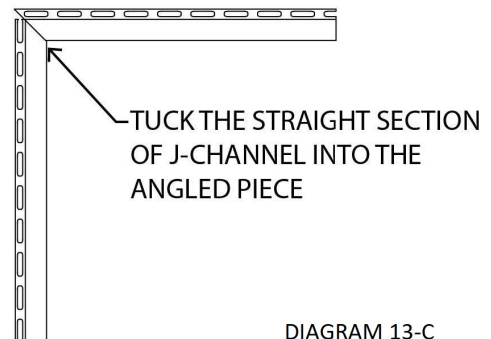

DIAGRAM 13-C

- **For the side piece of J-channel**

- Cut a piece of J-channel the height of the window frame + twice the width of the front of J-channel that is being used. Typically your cut will be 1 1/2" to 2" wider than the height of the window frame.
- At the top cut a notch out of the bottom of the piece of J-channel (See Diagram 13-B)
- At the bottom cut a tab in the bottom and bend it up 90° (See Diagram 14-B)
- Tuck the tab from the top piece (already installed) into the opening created by the notch at the top of the side piece. Be sure the face of the J-channel is tucked behind the miter cut.
- Do this for both sides and install pieces loosely until all pieces are installed

- **Bottom Outside Corner (See Diagram 14)** Used at bottom corners of windows, doors, etc.

- **For the bottom piece of J-channel**

- Cut a piece of J-channel the width of the window frame + twice the width of the front of J-channel that is being used.
- Mark and cut a 45° line from the bottom outside corners to create the false miter on the bottom of the window. Cut all the way through J-channel. (See Diagram 14-A)
- The tabs from both side pieces should tuck into the notches on each side, again be sure the the front tab of the side piece is tucked behind the mitered cut on the bottom piece. (See Diagram 14-C)

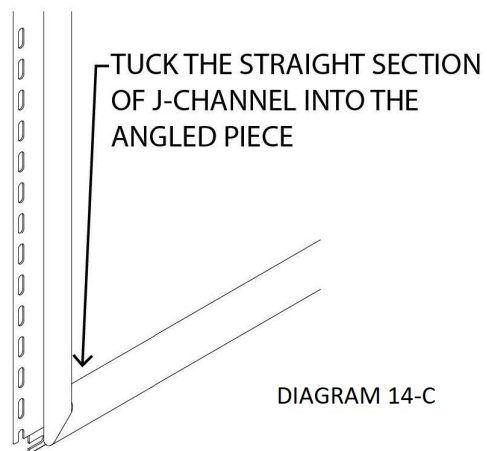
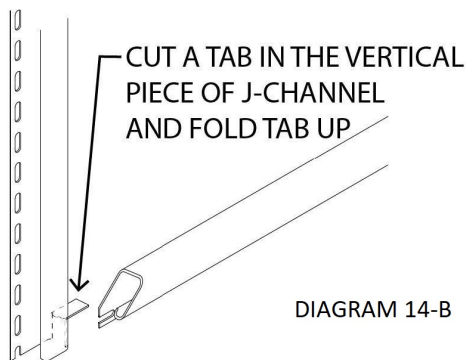
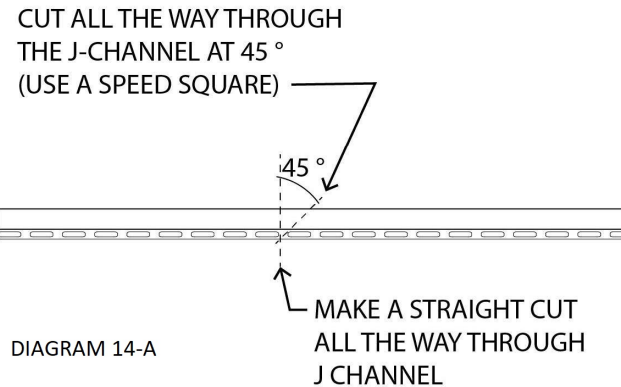

- **Inside Corner** (See Diagram 15)
  - Measure and mark where the inside corner is located on the house
  - Make a straight cut through the front and back of J-Channel, **but not the bottom** (See Diagram 15-A)
  - Use a speed square to mark and cut a 45° line into the cut previously made
  - The J-Channel is then folded to create the corner. Be sure to have the angle cut on the outside. (See Diagram 15-B)

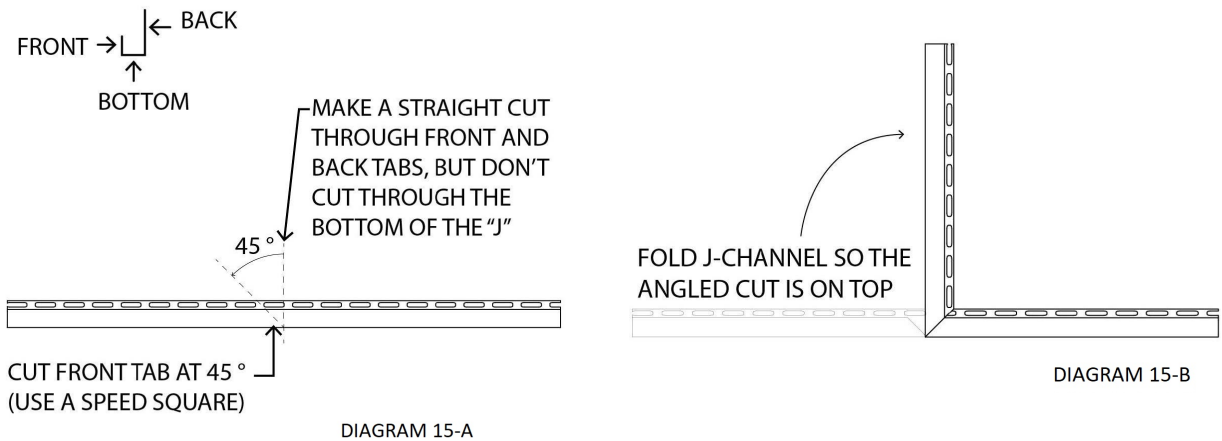

- J-Channel along bottom of wall:
  - Use a line level and chalk line to make a mark that will indicate the top of the J-channel
  - Allow for the J-channel to hang down 1" over the sheathing (See Diagram 16A)
  - Where applicable, the J-channel can be tucked into the channel of the inside/outside corner posts (See Diagram 16B)
  - Butt together pieces of J-channel as needed (See Diagram 12)
  - Drill 1/8" holes every 1'-2' in the bottom to allow water to drain out of the J-channel
  - If there is dramatic change in the base of the wall, the bottom J-channel can be stepped up or down using top outside corners (See Diagram 13 and 16B)
  - \*Starter strip can be used instead of J channel and should be attached every 6-8".

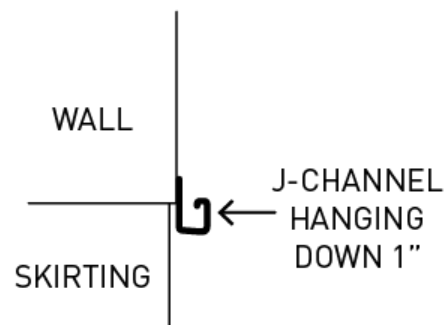
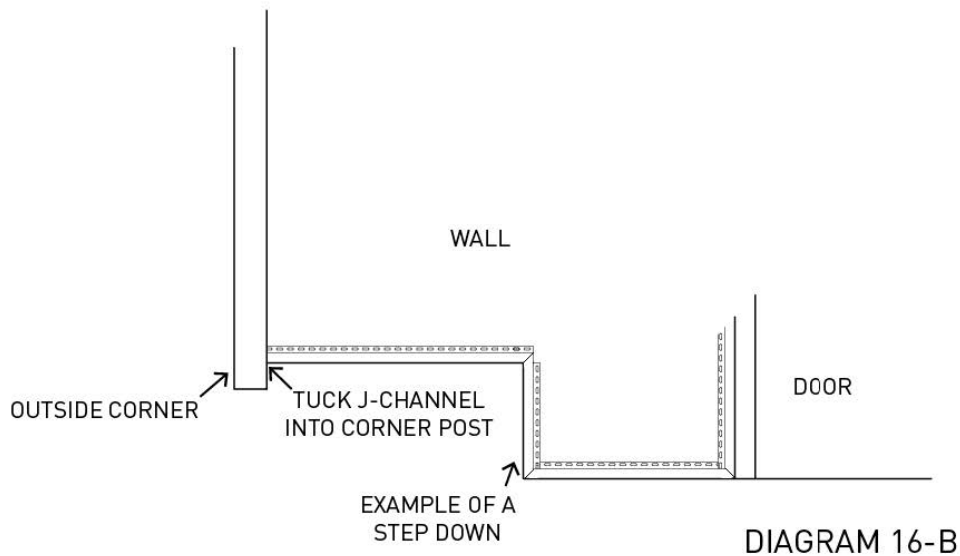

DIAGRAM 16-A



- **J-channel tips and tricks**

- Using the false miter method, especially on outside corners is a great way to have a clean and finished look. The tabs created are vital to keeping water going around the window instead of in the window.
- Getting a good measurement on J-channel can be difficult
  - Having a flat work station can help with this
  - You may find it easier to hold shorter sections of J-channel in place to mark where the cuts should be
- J-channel is very flexible. Take care that it is being nailed tightly against adjacent surface.
- Chalking a line to follow when installing J-channel or starter strip is an easy way to ensure it is level and straight.

- **J-channel across the top of the wall**

- This J-channel will be installed upside down to receive the top of the vinyl siding (See Diagram 17)
- The J-channel will sit tight against the soffit on both gable sides and eave sides of the house
- Like the J-channel at the base of the wall, the ends can be tucked into the corner pieces
- Butt ends together as needed (See Diagram 10)

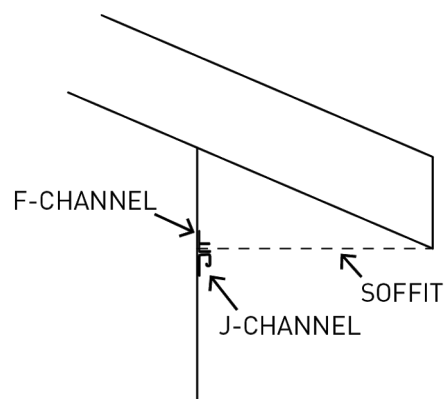

DIAGRAM 17

## Working Around Obstacles

- Working around electric service panels, hose bibs, electric outlets, light fixtures, and other obstacles are normal parts of siding installation
- There will likely be an electric service panel on every house, trim around those like you would a window
  - Slide the siding behind the conduit that comes out of the top if possible, if there is not then run J-channel on both sides of the conduit
- There are special mounting blocks for the following (these have J-channel built in around them)
  - Hose Bibs, these come apart and snap back together around the hose bib
  - Dryer Vents, these simply replace existing dryer vent covers
  - Outlets and Light Fixtures
    - These require removing the outlet/light and should only be done by someone with approval from the staff (otherwise see below for how to J-channel around these)
- If needed (or mounting blocks are not available) a combination of flashing and j-channel can be used to work around some of these obstacles (See Diagram 18)
  - White metal flashing can be slid behind light fixtures/outlets/mounted cable boxes and attached with white aluminum trim nails
  - Overlaps can be made if necessary with the flashing
  - Install J-channel around these areas as you would around a window

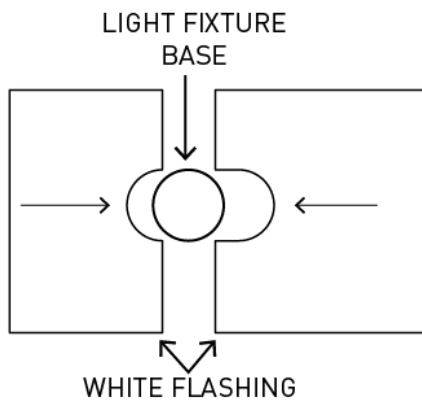

DIAGRAM 18-A

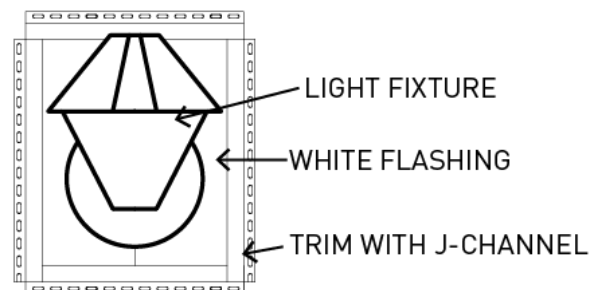

DIAGRAM 18-B

- Many times, cable/internet boxes can be opened and removed and then reattached on top of the new siding
- Sometimes the best option will also be cutting notches for small obstacles in the siding itself and then sealing with silicone caulk
  - *For example, if there is a cable that enters the house, cut a slit and small hole in the siding and work it around the cable, after the piece is installed add silicone caulk both around the cable and down the slit*

## Siding

- Pieces of siding will be installed working from one side of the house to the other
  - Do not work from both ends and meet in the middle, this will cause issues with overlap
  - For each individual wall, pick the corner from where the house will be seen most often and then start siding installation at the opposite corner of that wall (*so, for the side of a house start siding installation at the back corner of the wall and work towards the front corner of the wall*)
- Overlaps
  - The minimum overlap for pieces is 1 ½”
  - **A factory edge should always be on the outside of the overlap, a cut edge should never be exposed**
  - Each side on the house will use the “factory rights” or “factory lefts” depending on which direction you are working
    - *For example, if working from the back to the front on the right side of a house all the pieces installed with visible overlaps will be showing the factory right side of a piece, or “factory rights.” Therefore, all the scraps/cut pieces created will have “factory left” edges and should be saved because they may likely be used on the opposite side.*
- Installing the first row
  - The pieces in the first row will sit into the J-channel that has been installed along the bottom of the wall (See Diagram 19)
  - The ends of pieces will fit into the track of the corner posts/j-channel around doors
    - Pieces of siding should be cut and installed ¼” short of fitting all the way into the track to allow for expansion/contraction
  - Double check that the top of the piece is level
  - Attach the first piece
    - Attach every 12”-18” with roofing nails
    - **Do not pound nails in tight**, leave a nickel width behind each nail head so that the siding has the ability to expand and contract
    - Put nails in the middle of the nailing slots
  - Overlap the minimum 1 ½” and continue working across the side of the house

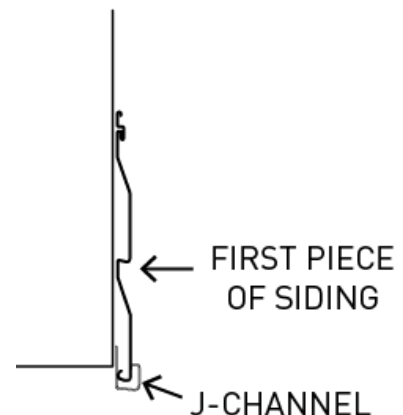

DIAGRAM 19

- Pieces shorter than 2' should not be used
  - If the remaining space in a row to be filled is less than 2', trim the length of a previous piece to ensure that the last piece in the row will be at least 2'
  - Trim off the side that will be on the bottom of an overlap
- Stagger the seams (See Diagram 20)
  - Seams should not stack on top of each other because then siding loses its water tightness
  - A good rule of thumb is to start the first row with a full 12' piece, the second with a piece around 9', the third with a piece around 6', and then repeat this pattern
  - The **minimum** space between seams in succeeding rows is 2' (sticking to the 12', 9', 6' pattern mentioned above helps prevent any issues with this)

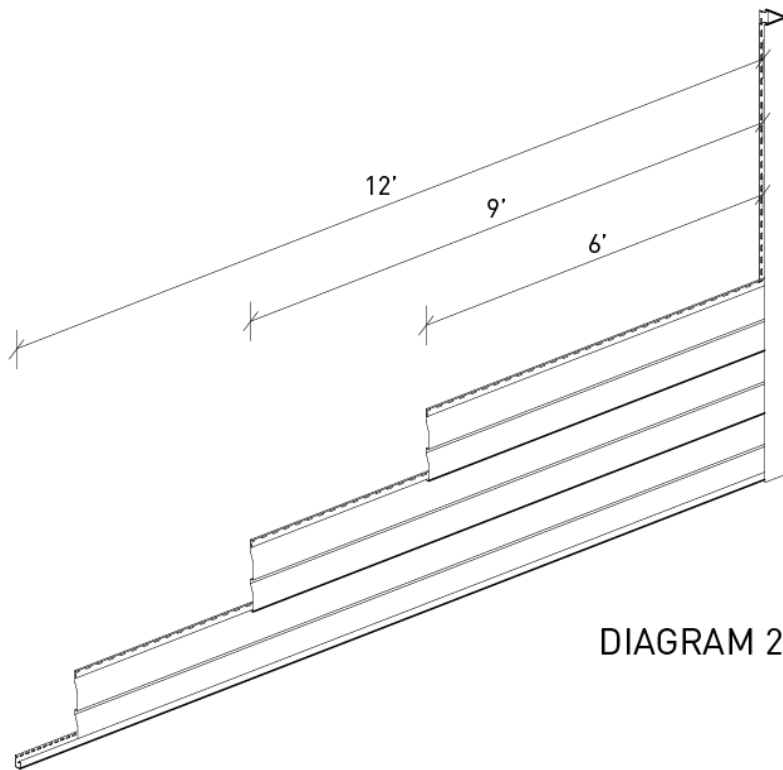

DIAGRAM 20

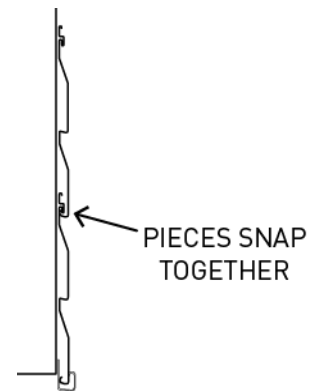

DIAGRAM 21

- Installing pieces after the first row
  - The pieces lock together (See Diagram 21)
    - Check at both ends and the middle by pulling out on the bottom of the piece to make sure that it is locked in before attaching
    - Put gentle, consistent, upward pressure on the bottom of the piece while fastening
    - Check every piece after installation to make sure that it is snapped together, if you find one later that has not been snapped in correctly, the only way to correct the issue is to remove all the pieces above it so that it can be snapped in correctly



- Installing each subsequent piece is the same as the first row. Remember these steps:
  - **Work from one side of the house to the other**
  - **Minimum 1 1/2" overlap**
  - **Attach every 12"-18" with roofing nails**
    - **Do not pound nails tight, leave a nickle's width space behind them for expansion/contraction**
    - **Put nails in the middle of the nailing slots**
  - **Make sure that pieces are interlocking by tugging out on the bottom of them**
  - **Stagger the seams by a minimum of 2'**
  - **No pieces shorter than 2' should be used (unless the space to fill is smaller than that)**
- Cutting siding to fit around obstacles
  - All of the edges of siding should be hidden by J-channel/trim that they are fitting into
  - A method for cutting notches: (See Diagram 22)
    - Hold the piece into place where it will fall side to side and slide it up into the J-channel
    - Make marks at where the cuts should be so they will fall 1/4" from the inside of the J-channel on the sides

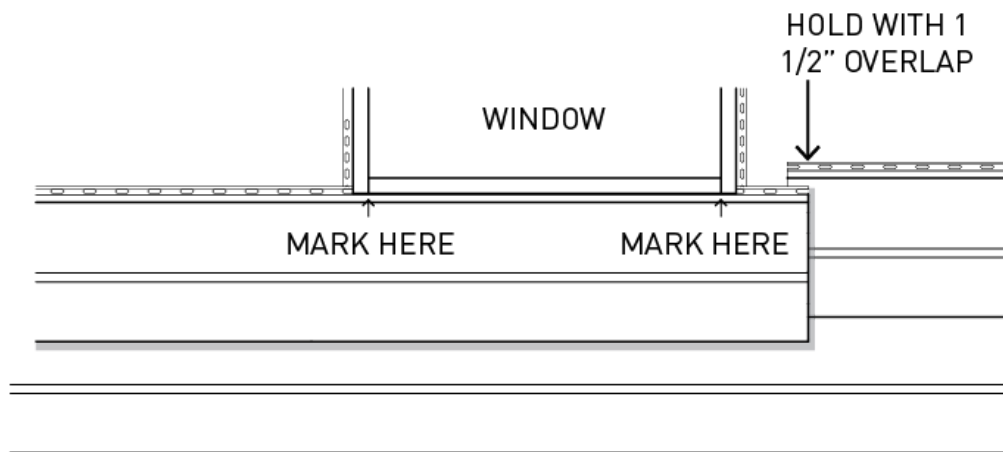

DIAGRAM 22-A

- Measure carefully from the bottom of the locking tab of the previous piece to the inside of the J-channel under the window (measure both sides, there is no guarantee that the window is square) (See Diagram 22B)
- Transfer the measurements onto the piece (See Diagram 22C)

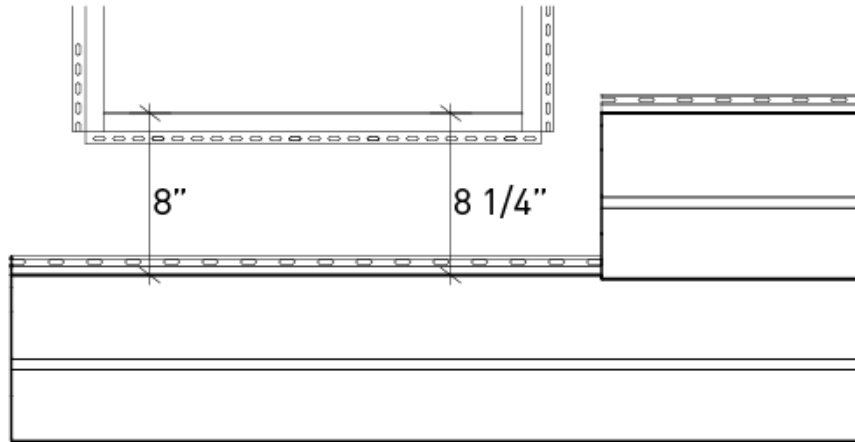

DIAGRAM 22-B

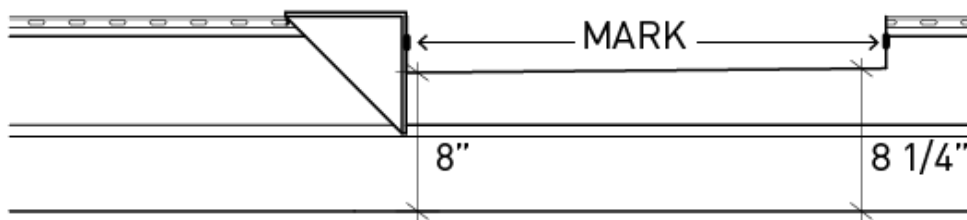
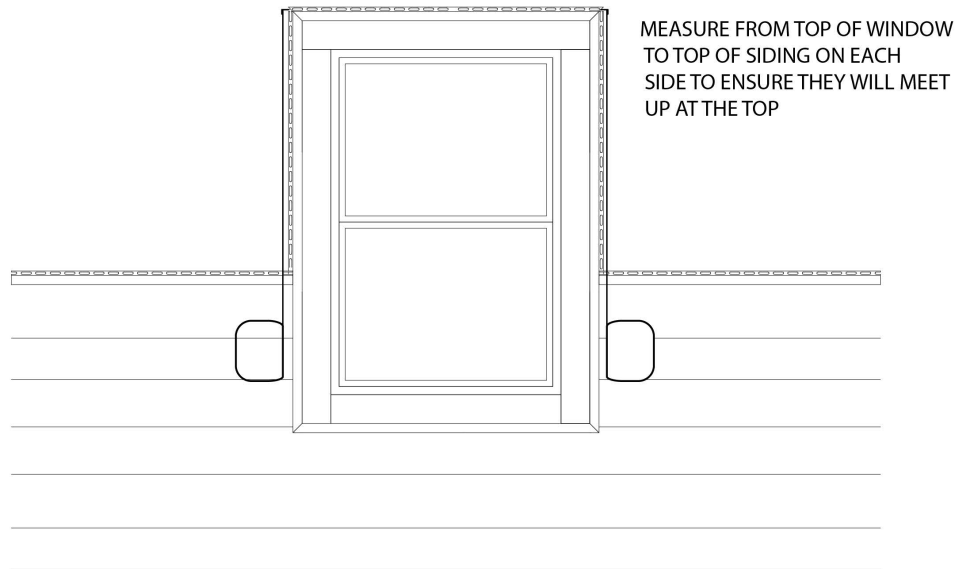

DIAGRAM 22-C

- When installing siding around windows its a good idea to measure down from each side of the window to current course of siding to make sure the measurements are the same.
- Siding can be stretched when installing and after a couple of rows its easy to become slightly higher or lower on each side of the window. This makes running the piece above the window difficult or impossible.
- Measuring as you work your way up the window will ensure the top piece can lock in on both sides of the window.



- There should not be a seam in siding pieces directly above a door or window
- This is tempting as it could make the notches easier, but it allows water to move into these places more easily
- Careful measuring can also be used to make notches around doors/windows

If in any situation you have to cut a notch that leaves a piece with no nailing flange where it terminates, use white trim nails through the weep holes in the bottom of the piece to help hold it into place (See Diagram 23)

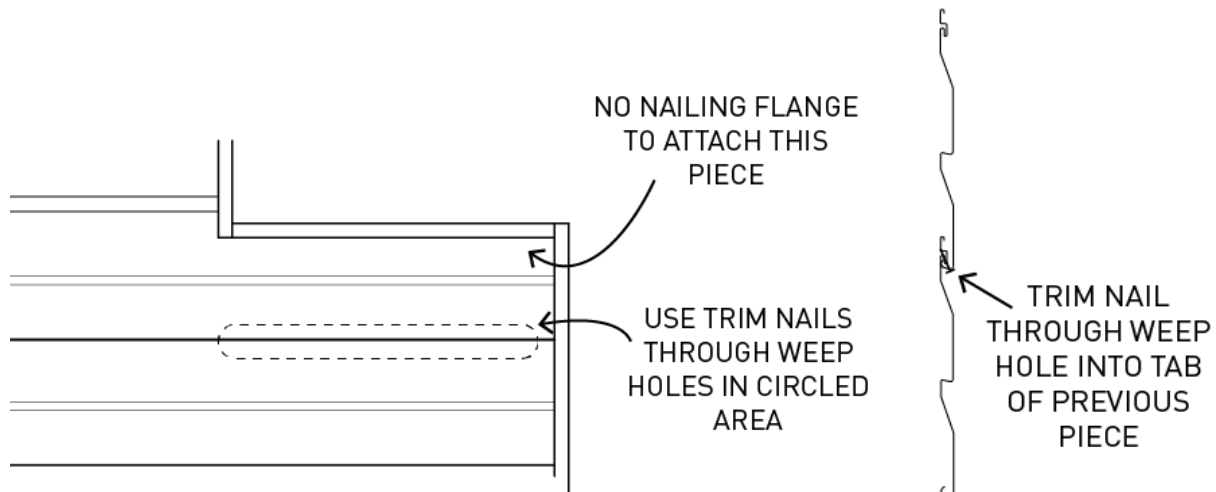

DIAGRAM 23-A

DIAGRAM 23-B

- Matching the profile of siding around the house (See Diagram 24)
  - If there is a situation where the siding to be installed on two intersecting sides of house that start at different levels, the first row on one of those sides can be trimmed so that the profiles of the siding line up at the corner
  - Use scrap pieces and test until you get the right height for the pieces to be trimmed
  - When installing these partial width pieces, make sure they sit down into the J-channel and that they are level when they are installed

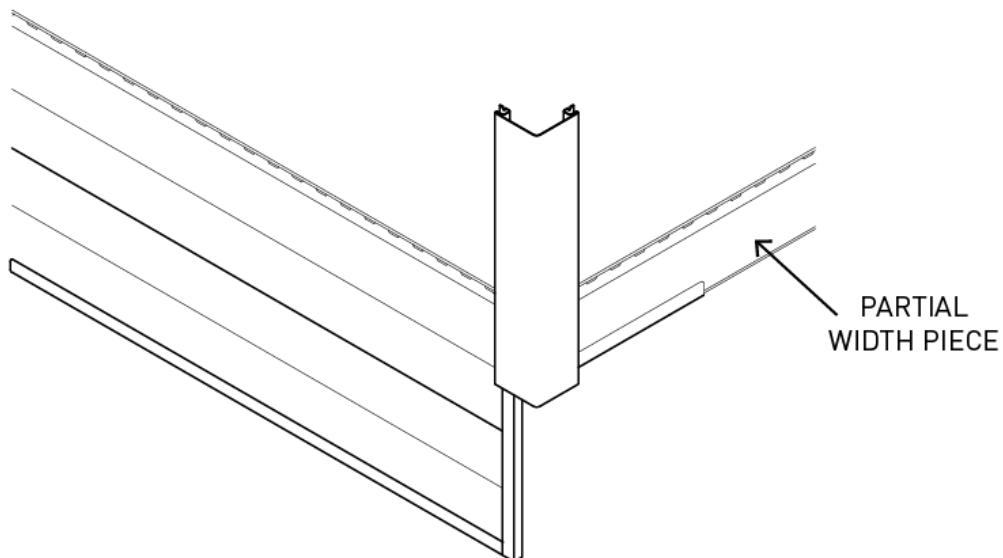

DIAGRAM 24

- Finding angles of siding (See Diagram 25)
  - If you are working on the gable side of the house, make a template for the angle of the roof that can be used to transfer that angle onto each piece to be cut
  - To do this use two pieces of scrap, lock one on to the previous row, and hold the other into the angled j-channel, trace the bottom of this piece

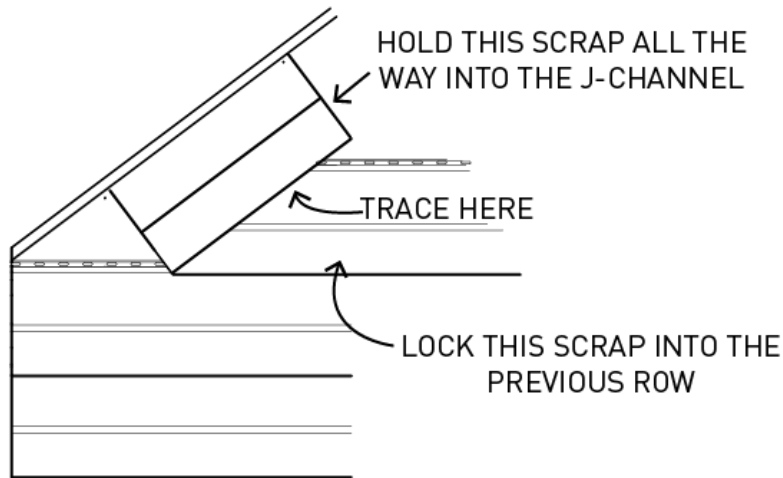

DIAGRAM 25

- Terminating siding at the top of the eave wall
  - Depending on how much of a piece of siding will be left there may need to be undersill trim (or p-channel) installed
  - If the top piece will be cut within an  $1\frac{1}{2}$ " over the middle ridge of the piece, the cuts should be made across the width of the siding and it will be stuck into the J-channel that is at the top of the wall (See Diagram 26)
    - White trim nails should be used through the weep holes in the bottom of this last row of pieces to help hold them into place (See Diagram 23B)

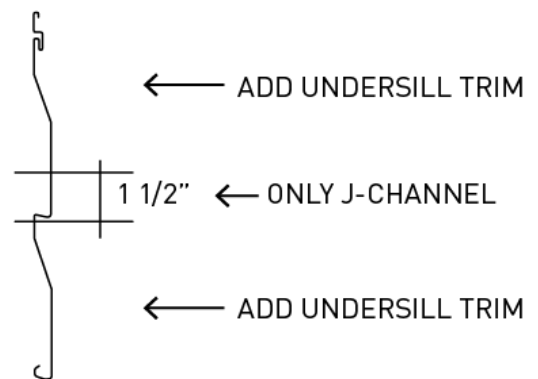

DIAGRAM 26

- If the last piece is cut below the middle ridge or more than 1 ½” over the middle ridge undersill trim/p-channel should be installed in the J-channel along the top of the wall, attach every 12”-18” with roofing nails (See Diagram 26)
  - The height of the last run of siding should be measured from the bottom of the nailing flange of the last run of siding to the bottom of where the siding will enter the undersill trim/p-channel and add ½” (See Diagram 27A)
  - Cut the siding width wise and test fit it into the undersill trim
  - Once you see that the piece will fit, use a snap-lock-punch tool to make tabs in the top of the piece
    - Make sure that the tabs are towards the outside of the piece
  - Insert the piece into the undersill trim making sure that it locks with the previous piece and that the tabs insert far enough into the undersill trim to hold the piece into place (See Diagram 27B)

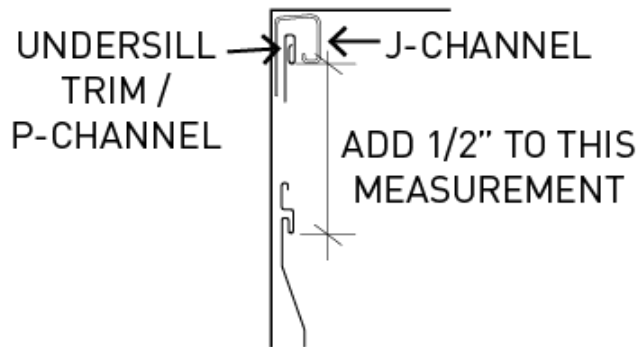

DIAGRAM 27-A

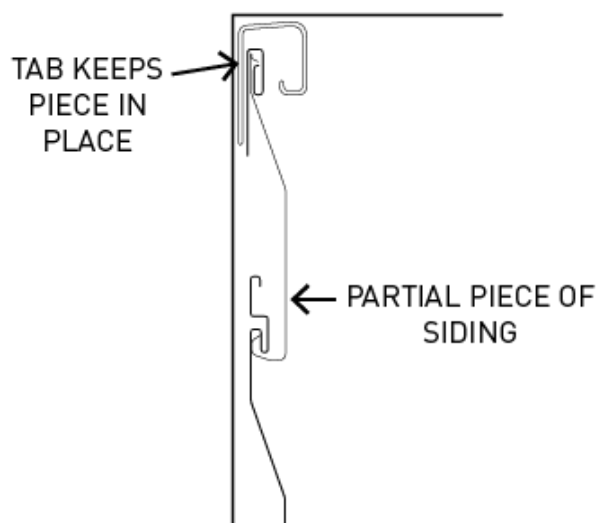

DIAGRAM 27-B

## Siding Materials Lists

| <u>Quantity</u>             | <u>Item</u>          | <u>Purpose/Notes</u>                                 |
|-----------------------------|----------------------|--|
| <b>Housewrap Materials:</b> |                      |  |
| ___                         | Roll(s) Housewrap    | Generally come in 100' rolls                         |
| 3-4                         | Rolls housewrap tape | To seal seams and around windows/doors               |
| 2-4 boxes                   | Staples              | Coordinate the correct type of staples to staple gun |
| ___                         | Button Cap Nails     | Can be used in place of staples/staple gun           |

**Housewrap Tools:** Staple gun, utility knives, ladders, hammers

## Vinyl Soffit Materials:

|         |                           |  |
|---------|---------------------------|--|
| ___     | 2x8 or 2x10 White Wood    | Angled piece of bird box, length for each corner is the same as the size of the eave overhang  |
| ___     | 2x4 or 2x6 White Wood     | Makes corner with angled piece to create bird box, length for each corner is the size of the gable overhang plus one foot  |
| ___     | F-Channel                 | <i>Length needed (in feet)/12' (length of one piece) = # of pieces needed</i><br>(can replace with J-channel if siding is not being installed with soffit)   |
| ___     | Solid Soffit              | For non-vented areas, typically gable sides  |
| ___     | Vented Soffit             | For areas vented to the attic space, typically eaves   |
|         |                           | <i>For both solid/vented:</i><br>→ <i>Width of overhang (in feet) x Length needed (in feet) = Area</i><br>→ <i>Area x 1.1 = Added 10% for error</i><br>→ <i>Area/12 SF (Size of one piece) = # of pieces</i> |
| ___     | Metal Fascia              | Size should coordinate to the size of the fascia board, length of pieces vary among suppliers<br><i>Length needed/length of one piece = # pieces</i>   |
| 1 Piece | J-channel                 | To catch soffit where gable ends intersect with bird Boxes (See Diagram 5B)  |
|         | Roofing nails             | 1 ¼" - 2" length, to attach f-channel to wall and soffit pieces to fascia  |
|         | White Aluminum Trim Nails | For attaching metal fascia and holding first pieces of soffit into place   |
|         | 3" Deck Screws            | Constructing the bird boxes  |

## Vinyl Siding Materials:

|     |                            |  |
|-----|----------------------------|--|
| ___ | Outside Vinyl Corner Posts |  |
| ___ | Inside Vinyl Corners Posts |  |
| ___ | J-Channel                  | <i>Length needed (in feet)/12' (length of one piece) = number of pieces needed</i><br>Across the bottom and top of each wall, around all windows/doors/etc.  |
| ___ | Utility trim/P-channel     | <i>Same equation as J-channel</i><br>Across the top of the wall on eave sides of home  |
| ___ | Siding                     | → <i>Length of wall (in feet) x Height of wall (in feet) = Area</i><br>→ <i>Add together area for each wall = Total Area</i><br>→ <i>Total Area x 1.1 = Added 10% for error</i><br>→ <i>(Area + 10% error)/100 SF = ___ Squares Siding</i><br>Vinyl Siding is ordered by the "Square"<br>(1 Square = 100 SF), number of squares in a box will vary with supplier |
|     | Roofing Nails              | 1 ¼" - 2" length, used to attach all vinyl trim and hang pieces of siding  |
|     | White Aluminum Trim Nails  | To hold pieces in place through weep holes under windows/across the top of the wall  |
|     | White Flashing             | If needed to work around lights/boxes/etc.   |
|     | Mounting Blocks            | For hoses/dryer vents/etc. (as applicable)   |

## Recommended Vinyl Soffit and Siding Tools

### **Safety:**

Gloves  
Glasses

### **Other (Soffit Only):**

Circular Saw - for cutting pieces for bird box  
Extension cord  
Drill  
→ ⅛" drill bit - pre-drilling for bird box (for soffit only) and weep holes in bottom run of J-channel (for siding only)  
→ T-25 Driver to match screws for building birdbox

### **Other (Siding Only):**

Snap Lock Punch Siding Tool - used to make tabs in pieces for the top row  
Vinyl Siding "Hook" Tool - Used to help lock siding into place in tight spots or to remove a piece

### **General Tools:**

Basic Hand Tools (Tape measures, hammer, pencils, speed square, etc)  
4' Level  
Tin Snips - for cutting vinyl  
Framing/Speed Square - for marking vinyl  
String line/String level  
Chalk Line  
Ladders  
Saw Horses





# Insulation, Vapor Barrier, & Air Sealing

## Insulation

**Why insulation?** Insulation reduces heat loss from the home in the winter and reduces heat gain in the summer, reducing heating and cooling costs.

### Safety

- Wear long sleeves, gloves, glasses, and dust masks while working with insulation
- When insulating in an attic space, work on scrap OSB to keep weight distributed across ceiling joists
- Make sure staple gun is against wood when fastening, do not test in air
- While working in crawl spaces, watch out for water leaks/critters/etc.

### Insulation Project Planning

- Will insulation be protected once it is installed? Are there any plumbing leaks that need to be addressed before insulation is installed? Are there any leaks or any gaps in the underpinning (crawl space insulation) or soffit (attic insulation)? Address those issues as well
- Is crawl space/attic space safe for volunteers to work in?
- Make sure to use appropriate R-value of insulation for area being insulated (See page 159)
- Make sure volunteers will have adequate light to work - shop lights/flashlights
- Make sure volunteers have long sleeves, glasses, gloves, and masks

### Measurements Needed

- Square footage of area to be insulated
- Size of rafters/floor joists/studs where insulation will be installed
- Spacing of rafters/floor joists/studs

## Quality Control

- Make sure paper faces the conditioned area - “paper to the people”
- Is the insulation touching the surface it is intended to insulate? (but not compressed)
- For floor insulation, make sure there is some additional support that holds the insulation up (strips of house wrap/mesh/etc.)

## Common Mistakes

- Insulation installed paper down from in the crawl space because it is easier
- Insulation installed with paper to the outside, the insulation will likely not touch the surface that is supposed to be insulated

## After Work is Complete Quality Control Check

- Is insulation installed with paper to the insulated space, “paper to the people”?
- Is the insulation held in place well?
- Fiberglass Batt Insulation

### There are three common types of insulation.

- Designed for certain framing widths (for 16” or 24” on center)
  - Typically pieces are 8’ long
  - Comes in different R-values depending on where it will be used (floors, walls, etc.)
  - Packaged in rolls by square footage
  - This is the easiest to install and most commonly used insulation
  - Installation instructions below
- Cellulose/“Blown In” Insulation
  - Loose insulation material, blown into place using a mechanical blower
  - Most commonly used in attics
  - Has highest R-value per inch of thickness
  - Mechanical blower can be rented and instructions followed for installation
  - Avoid covering up venting and add baffles if needed (See page 97)
  - Allow a 3” gap around any heat producing obstruction (chimneys, wood stove stacks, etc.)
- Expanded Polystyrene Foam (EPS)
  - Come in 4’x8’ sheets at different thicknesses
  - Often white with a reflective silver foil facing
  - Seams of foam sheets should be sealed with tape
  - Appropriate for insulating walls
- Extruded Polystyrene Foam (XPS)
  - Come in 4’x8’ sheets at different thicknesses
  - Often blue or pink
  - Seams of foam sheets should be sealed with tape
  - Appropriate for insulating walls and roofs

## **R-Value**

- The R-value is the resistance value of a material to the flow of heat
- The higher the R-value, the better insulator the material is
- R-Value requirements depend on the Climate Zone the work is being done. Be sure to confirm with local building department.
  - Floors: R-19 up to R-30
  - Walls: R-13 up to R-20
  - Ceilings: R-30 up to R-49

| <b>Material</b>            | <b>R-Value</b> | <b>Thickness</b> |
|----------------------------|----------------|------------------|
| Fiberglass Batt Insulation | R-11           | 3.5"             |
|                            | R-13           | 3.5"             |
|                            | R-15           | 3.5"             |
|                            | R-19           | 5.5"             |
|                            | R-21           | 5.5"             |
|                            | R-30           | 8.5"             |
|                            | R-38           | 12"              |
| Drywall                    | R-.45          | ½"               |
| Plywood                    | R-.65          | ½"               |
| Concrete Block             | R-1.1          | 8"               |
| Asphalt Shingles           | R-.15          | ⅛"               |

## **Fiberglass Installation Instructions:**

### **Working with fiberglass:**

- Safety
  - If fiberglass comes in contact with skin it can cause itching
  - Fiberglass should not be inhaled
  - Wear gloves, long sleeves/pants, dust masks, and safety glasses when working with fiberglass
  - After working with fiberglass, take a cold shower (hot water can open pores and can make skin more irritated)
- Material Care
  - Insulation should be stored in an area so that it will not get wet
  - If material does get wet, lay it out to dry
  - Do not install material if it is wet, moisture can transfer to structure and cause rot
  - Avoid compressing the material, as the R-value decreases when the material is compressed

### **Installation**

- Determine if using faced or unfaced insulation (see sections below)
- Pieces of insulation should be installed so that they will be in contact on 5 sides
  - *For example, pieces of insulation in floors should be touching joists on two sides, band joists on two sides, and the subfloor*
  - In runs longer than 8', pieces should butt against one another
- Cutting fiberglass
  - Hold a 2x4 scrap or straight edge across the insulation
  - Make cuts with a utility knife until through the material
- For electrical boxes/plumbing vents/ductwork/etc, cut tightly around the shape to reduce air flow
- Avoid compressing the material as that causes it to lose effectiveness
- Specifics for installation of faced and unfaced fiberglass insulation below

## Faced Insulation

- Faced insulation has a paper “facing” on one side
- Faced insulation applications
  - In walls (See Diagram 1)
  - When working on the floor system from the top, so that the tabs can be folded out and stapled to top of floor joists (See Diagram 2)
  - Can be used in ceilings when installing from below so that tabs can be folded out and stapled to the bottom of the ceiling joists/rafters (unfaced can also be used in this application, see the next section) (See Diagram 3)
- Insulation should be installed with the paper facing towards the insulated area
  - “Paper to the people”
- Insulation should be put into place and tabs on paper facing unfolded to cover the face of the framing member
  - Attach with staples every 18” through paper tab into stud/joist
  - Paper facing tabs should overlap one another from adjacent pieces

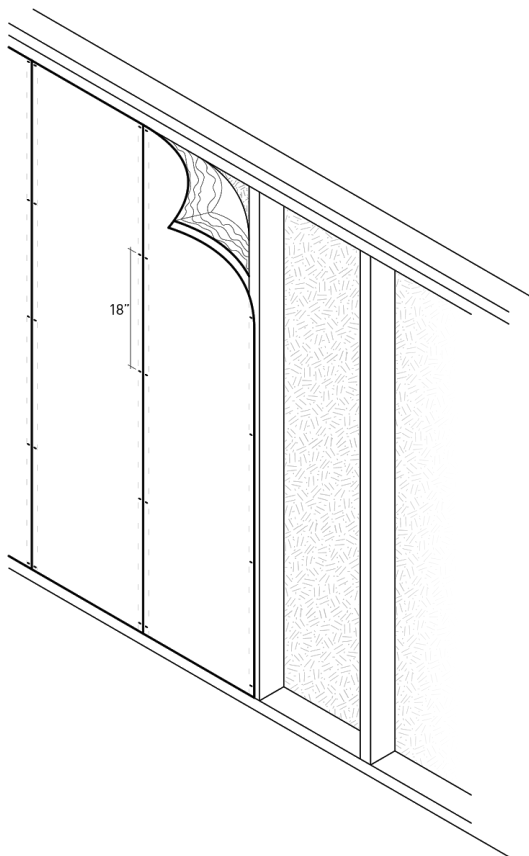

DIAGRAM 1

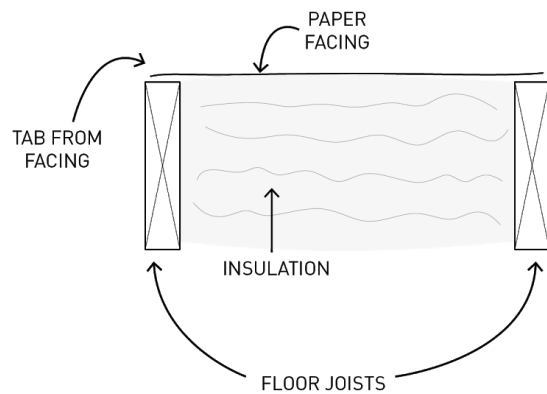

DIAGRAM 2

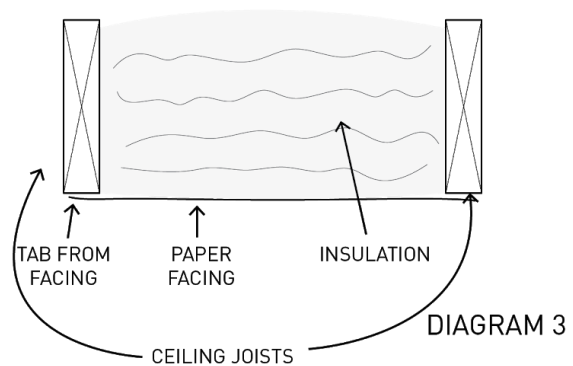
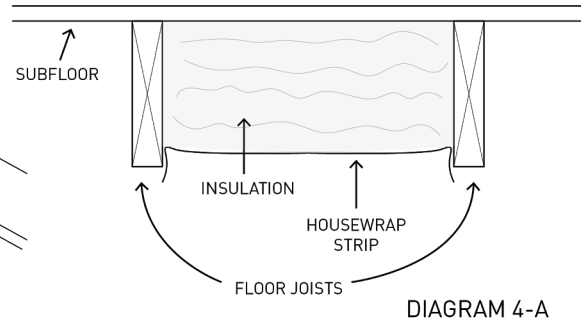
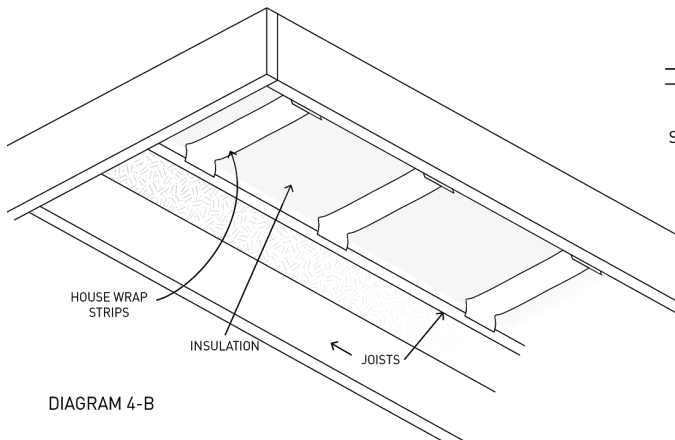

DIAGRAM 3

## Unfaced Insulation

- Unfaced insulation has no paper facing on either side
- Unfaced insulation applications
  - When installing in floors from underneath (See Diagram 4)
  - In attic space (See Diagram 5)
- Floors from underneath:
  - Strips of housewrap should be cut (about 4"-6" wide and slightly longer than joist spacing), these will be used to hold insulation in place
  - Strips should be stapled perpendicular to the joists
  - Install strips every 18"
  - Strips should be tight enough that the insulation is touching the subfloor, but is not compressed



- Attic space
  - From underneath (before drywall)
    - Run strips of drywall tape or strips of housewrap perpendicular to the ceiling joists every 24" on center, tacking it with staples
    - Lay pieces of insulation above the tape
  - From above (after ceiling drywall)
    - Lay pieces of insulation in bays directly on top of drywall
    - If working in the attic space, bring flashlights/work lights if needed
    - Sit scrap OSB set across ceiling joists for a working surface, rather than balancing on ceiling joists
    - Be cautious of putting any weight on top of ceiling drywall
  - For any chimney or other heat producing obstruction in the attic space, allow a 3" gap from the insulation

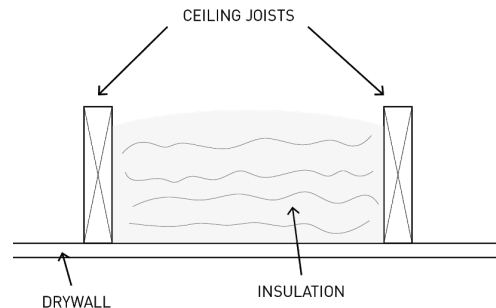

## **Insulation Material List**

| <u>Quantity</u> | <u>Item</u>                | <u>Purpose/Notes</u>  |
|-----------------|----------------------------|---|
| ___SF           | Fiberglass Batt Insulation | Determine: <ul style="list-style-type: none"><li>• Faced or Unfaced Insulation</li><li>• Width of insulation (based on spacing of joists/studs)</li><li>• R-value of insulation</li></ul> |
|                 | Housewrap                  | To hold insulation into place from underneath if needed   |
|                 | Staples                    | To hold insulation into place, coordinate size to staple gun  |

## **Recommended Tools**

### **Safety**

Glasses

Gloves

Dust Masks

Long Sleeves

Tyvek Suits - can be used if working in crawl space or attic if needed

### **General**

Basic Hand Tools (Tape measures, hammer, pencils, speed square, etc)

Utility Knife - to cut insulation and housewrap

2x4 or Straight Edge - to cut insulation

Saw Horses

Staple Gun

Drop Lights and Flashlights if needed

Ladder (if applicable)

# Vapor Barrier

A vapor barrier is a protective layer intended to keep moisture from penetrating a certain area. Vapor barriers should be installed under homes to keep moisture out of the crawl space. Accumulated moisture in the crawl space can lead to poor air quality in the home, structural rot, mold, etc.

## Preparation

- Clean out the crawl space, removing debris or stored items
- Address any standing water

## Lay Plastic Sheets

- 6 mm plastic (minimum thickness) should be rolled out to cover the entire floor of the crawl space
- Plastic should extend 6" up the walls/underpinning and all piers
- Overlap seams by 3"

## Seal Edges with Tape

- Use a moisture resistant tape (housewrap tape works well)
- Tape all overlap seams
- Tape the edges of the plastic to the wall/skirting/piers

## Vapor Barrier Material List

| <u>Quantity</u> | <u>Item</u>            | <u>Purpose/Notes</u>                |
|-----------------|------------------------|-------------------------------------|
| ___ SF          | 6 mm plastic (minimum) | Square footage of crawl space floor |
|                 | Housewrap Tape         | To tape seams of vapor barrier      |

## Recommended Tools

### Safety

Glasses  
Gloves  
Dust Masks  
Tyvek Suits - can be used if working in crawl space

### General

Basic Hand Tools (Tape measures, hammer, pencils, speed square, etc)  
Utility Knife - to cut insulation and housewrap  
Drop Lights and Flashlights if needed



# Air Sealing

Air sealing is the process of reducing voids that lead to drafts/heat loss, creating a continuous building envelope. This can lead to energy savings and reduced heating/cooling costs.

## Framing/Sheathing

- If a wall is open and exposed while work is being done, caulk can be added along the intersection of the bottom plate of the wall and the subfloor to prevent air movement
- Seams of sheathing for walls can be sealed with mastic or caulk if they do not land on studs
- Penetrations through framing or sheathing should be sealed
  - Plumbing/electric lines that run through walls or floor should be sealed with a fire rated caulk or fire rated spray foam insulation (should be used if gap is too large for caulk)

## Drywall

- Seams and corners of drywall need to be taped/mudded to prevent air penetration
  - If a moulding/trim is used where the ceiling and wall meet, it needs to be caulked to air seal
- All penetrations through drywall should be sealed with tape/mud or caulk
  - Plumbing lines should be caulked

## Rigid Foam

- Rigid foam board can be installed on the outside of wall sheathing to add both insulating and air sealing qualities
- All seams of foam should be taped to prevent air movement
- This method is used in ASP's "Hug System" (see page 285)





# Drywall

**Why drywall?** Drywall is used to help create ceilings and interior walls, drywall also adds fire resistance and air seals the insulated space.

## **Safety**

- Have multiple people in place when moving drywall, drywall is heavy and fragile
- Wear dust mask and glasses when sanding drywall mud
- Use ladder safety from page 11
- Mark wires/pipes/etc. in wall/ceiling before concealing to prevent hitting them with a screw

## **Drywall Project Planning**

- Make sure there is a storage space where material will stay dry
- If drywall is moisture damaged and needs to be replaced, will there be framing or insulation behind damaged drywall that also needs repair?
- Is the source of drywall damage addressed? Leaky windows/ac units/roofs?
- What kind of outlets/vents/fixtures will you have to work around?
- Provide materials for t-braces and make sure there are ladders if needed
- Will existing trim/baseboard need to be removed? Will it be replaced?
- Will any permits/inspections be needed before drywall is hung?
- Is needed blocking in place before hanging drywall?
- Is there enough work available to keep everyone busy while mud dries?
- Will drywall be finished flat or textured?
- Where is source of water to clean tools?

## **Measurements Needed**

- Surface area where drywall will be installed
- Thickness of existing drywall if matching
- Number of corner bead pieces needed for outside corners?
- Spacing of ceiling joists

## Quality Control

- Are the edges of drywall falling on studs?
- Make sure ceiling drywall is hung perpendicular to ceiling joists
- Are screw heads below the face of the drywall?
- Is drywall fastened adequately? (Every 8" on ceiling, 12" on wall)
- Make sure mud dries completely between coats
- Make sure tape is flat (no bubbles/bumps)
- Are the appropriate sized knives being used for each coat? (6", 10", 12")
- Make sure coats of mud are thin
- Make sure mud is sanded well after last coat
- Make sure tools are cleaned and dried thoroughly between each coat

## Common Mistakes

- Additional blocking not added for edges of drywall in corners
- Screw heads not countersunk and sticking out above surface
- Not enough screws into ceiling joists
- Rushing to get needed number of mud coats
- Air bubbles in tape because tape not flattened out with knife
- Knives being used for all coats are too small
- Unnecessary sanding because coats of mud are too thick
- Seams are still visible
- Tools washed off but not dried will rust quickly

## After Work is Complete Quality Control Check

- Wipe off all dust from drywall and vacuum/sweep before painting
- Is drywall smooth and sanded well?
- Will baseboard/trim be installed as well?

## Material Information

- Drywall comes in 4'x8' and 4'x12' sheets
  - 4'x8' pieces are much easier to work with and transport
- Thickness of sheets ranges from 1/4" to 5/8"
- Material should be stored inside and cannot get wet
- "Green/Blue Board" is a moisture resistant drywall that should be used in areas that will be exposed to moisture ( *around showers, sink backsplashes etc* )
- 5/8" Drywall is recommended for ceilings joists spaced 24" OC.

# Drywall Installation Instructions

## Preparation

- Needed inspections should be completed (framing/plumbing/electric/insulation)
- Nailers should be added if needed in corners so that vertical edges of drywall have something to attach to
- Scan studs/ceiling joists, remove any nails/screws that will interfere with the drywall
- Check if the ceiling/walls are square. If not, know that pieces may have to be cut at slight angles to accommodate

## Hanging Drywall

- The side of the drywall with the brown paper face is the back and should be installed facing the joists/studs
- When hanging drywall, work from the top down
  - Ceiling drywall should be hung before wall drywall
  - Top course of wall drywall should be hung before bottom course
- Seams of drywall should be staggered
- Factory edges should meet other factory edges and cut edges should face corners
- Keep seams tight as pieces are installed
- Fastening
  - 1 5/8" drywall screws should be used
  - Screw head should create a slight dimple and recess slightly below the surface of the drywall
  - Dimpler bits can be used to control screw depth
  - Avoid attaching right at the edge of a piece, this will break the drywall
    - If drywall does break, leave the screw in place (so long as the screw head is below the surface) and add another screw close by
- Specifics of ceiling and wall drywall below

## Cutting Drywall

- Cutting across the full piece
  - Use a utility knife and a straight edge, usually a t-square (See Diagram 1A)
  - Score front of drywall, running utility knife blade along the straight edge
  - Sharply bend the drywall away from the scored side and it should snap (See Diagram 1B)
    - Can stand the piece up on the long edge and bump it with a knee on the opposite side of the score line
  - Use the utility knife to cut the paper along the back (See Diagram 1C)

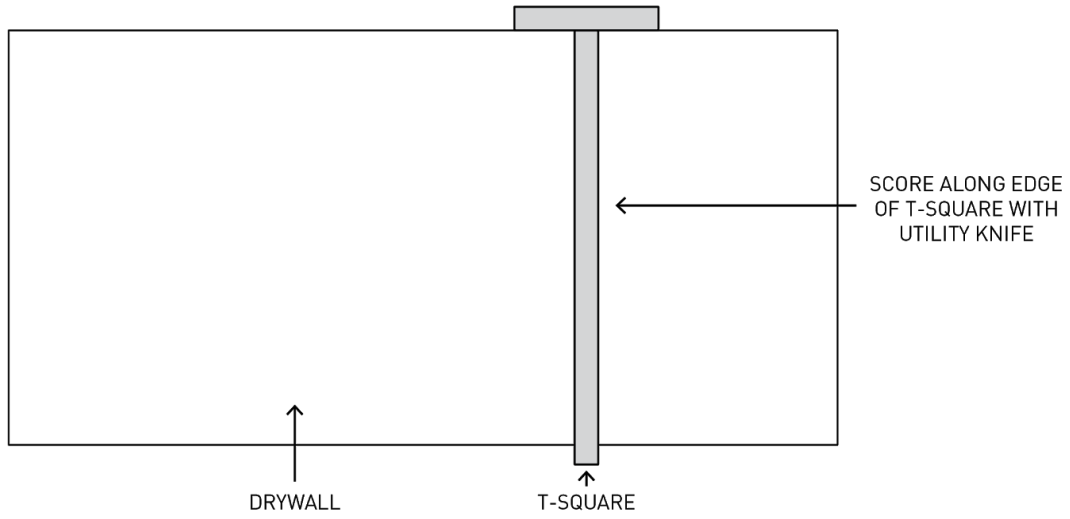

DIAGRAM 1-A

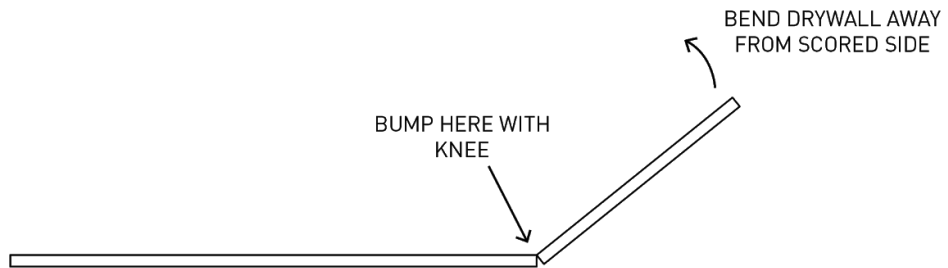

DIAGRAM 1-B

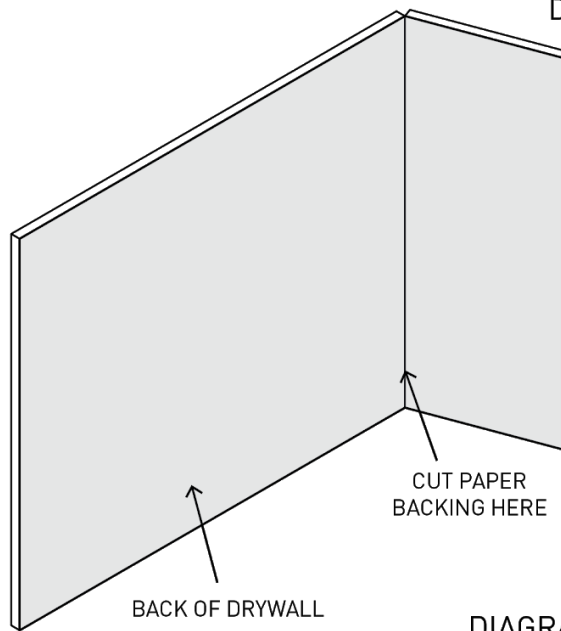

DIAGRAM 1-C

- Cutting small penetrations
  - For plumbing pipes or other round penetrations, use a drill bit or hole saw attachment on a drill to make a clean hole
  - For electrical boxes or other small penetrations, measure and mark area to be cut out
    - Use a key hole saw (also called drywall saw) to make the cut
      - Short, fast strokes back and forth with this saw work best
      - Brace piece well, cuts are difficult if piece moves back and forth
- Windows/Doors
  - Rather than measure for windows or doors, pieces can be installed over them and then they can be trimmed (See Diagram 2)
    - Cut portion over the window frame with a key hole saw, keeping blade against the framing
- If a piece is cut slightly too long a drywall rasp should be used to shave the piece down, small trim cuts are difficult to make with the score and snap method or with a key hole saw

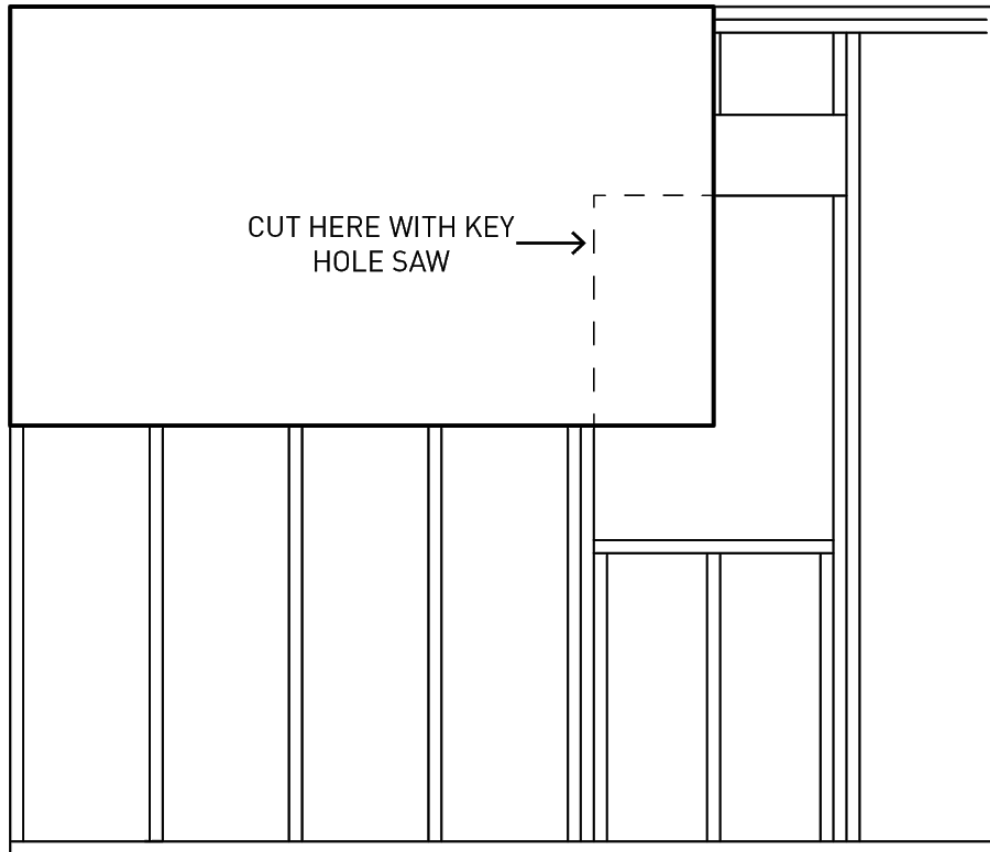

DIAGRAM 2

## **Ceiling Drywall** (See Diagram 4)

- On ceilings, drywall will run perpendicular to the ceiling joists
  - Short edges of drywall should fall on ceiling joists
- ½" drywall should be used on ceilings with joist spacing of 16" OC and 5/8" drywall should be used with 24" OC joist spacing.
- Mark the locations of the ceiling joists on the wall so that they are easy to locate once the piece is in place (tape can be used if walls are finished)
- Build T-braces to help hold the piece in place while it is being fastened (See Diagram 3)
- Have someone ready with screws and drill before piece is lifted into place because holding the drywall overhead is difficult
- Attach every 8" along each ceiling joist
- Light fixtures should be removed if possible, or loosened (cut power off at breaker box before making any changes with light fixture)
- For overhead light boxes, measure and mark where these will go and cut before installing
  - Carefully transfer measurements so that piece will be in the correct orientation, it is easy to mark the reverse image since the piece will be hanging upside down

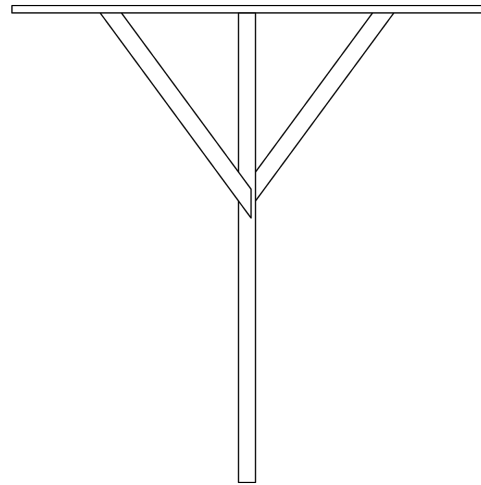

DIAGRAM 3

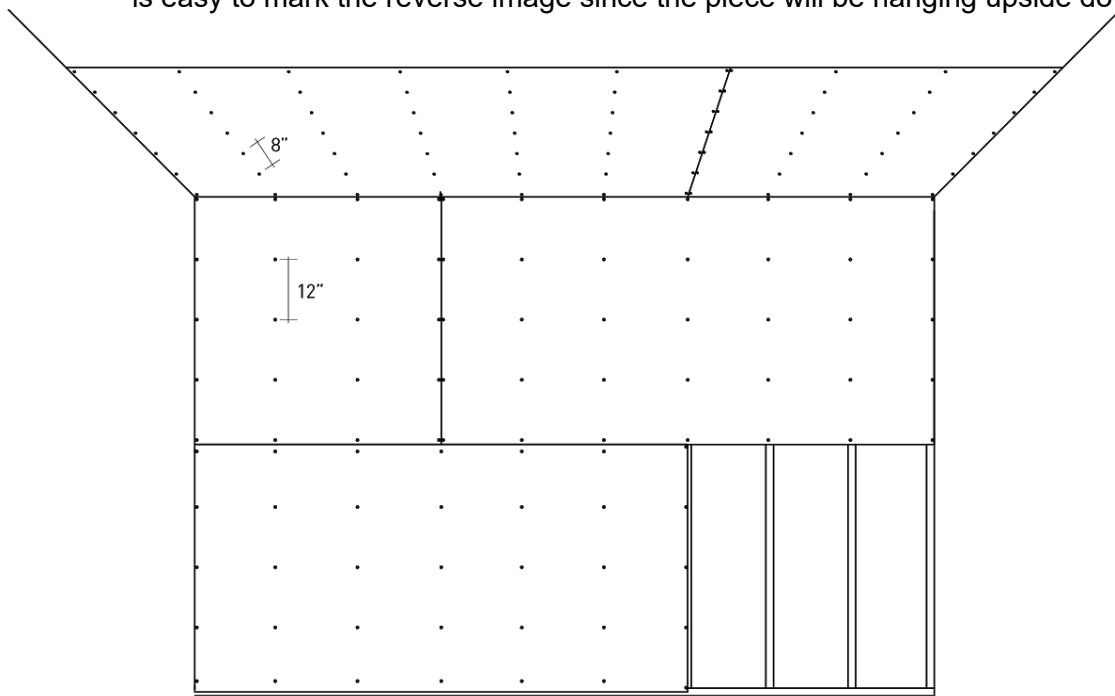

DIAGRAM 4

1/2" GAP BETWEEN  
DRYWALL AND FLOOR



## **Wall Drywall** (See Diagram 4)

- On walls, drywall can be hung vertically or horizontally
  - Horizontal is ideal because it requires less time on a ladder
  - Vertical edges of drywall should fall on studs
  - For walls that are less than 4' wide, pieces can be run vertically so that there is no seam in that wall
- ½" drywall should be used on walls (unless matching an existing thickness for a patch)
- Top courses should be hung first, then lower courses
- Mark on the ceiling and/or floor where the studs are so that they are easy to find when covered with new drywall
- Measure, mark, and cut out for electrical boxes/plumbing/ etc. before piece is installed
- The bottom of the bottom course should be at least ½" off the ground
  - Put the flat end of prybar under drywall, put block under the center of prybar, and apply pressure with foot to lift the drywall and make a tight seam at the top of the piece
  - Can do this at both ends of piece of drywall
- Fasten every 12" along studs

## **Corner Bead** (See Diagram 5)

- Corner bead should be installed over outside corners
- Corner bead is typically vinyl or metal material and can be cut to length using tin snips
- Attach corner bead every 6" using drywall nails (not screws - the heads protrude and make it difficult to finish)

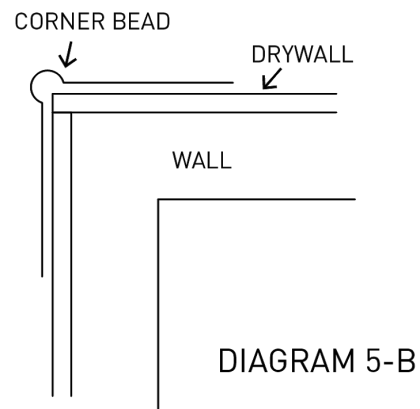
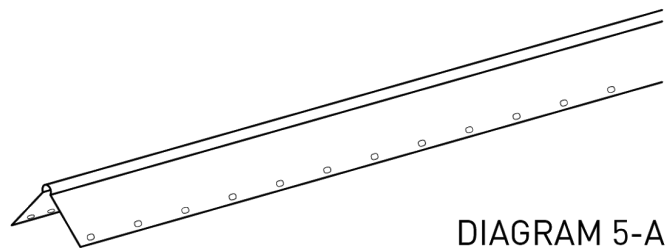

## Taping

There are two types of drywall tape

- Paper tape
  - Most commonly used tape
  - Installed with mud, paper tape is not adhesive
  - Pre-creased for easy installation in inside corners
  - Always used for inside corners (including joint of wall and ceiling)
  - Applied with first coat of mud
- Mesh tape
  - Adheres directly to the wall/ceiling
  - Not used for inside corners
  - Applied before first coat of mud

## How to Work With Drywall Mud

- Specific directions for each coat of mud are below
- Vacuum/sweep area well before starting to use mud and between coats/sanding
  - Loose particles that get into mud or onto the drywall surface make it difficult to finish mud
- Put mud into a tray to work with it more easily
- After mud has been removed from the original container, it should not be put back into the container
  - Work with small amounts of mud at a time to avoid waste
- Add a small amount of water to the mud and mix it
  - Consistency should be similar to mayonnaise
- After putting mud onto the knife, knock the mud off of each corner before applying to the wall (See Diagram 6)
- Close mud container when it is not being used to prevent drying out

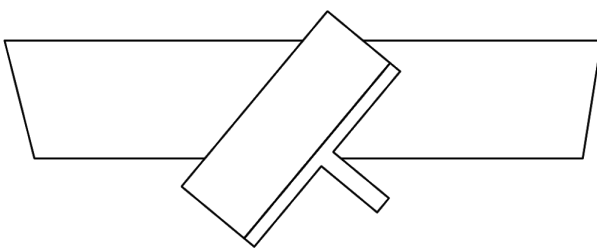

DIAGRAM 6-A

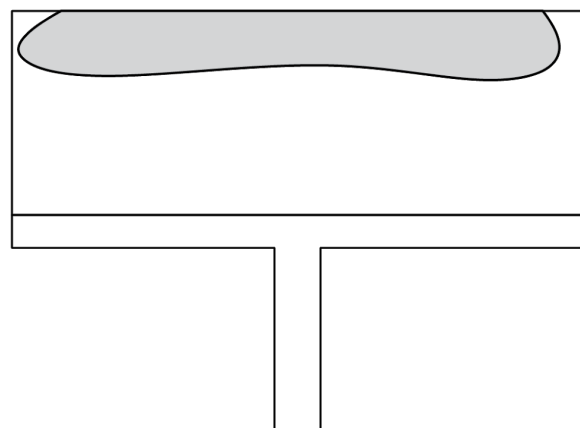

DIAGRAM 6-B

- When applying mud to the drywall, start with the knife perpendicular to the drywall, as it is fully loaded, and then start to tilt it more parallel to the drywall as mud is moved from knife to drywall (See Diagram 7)

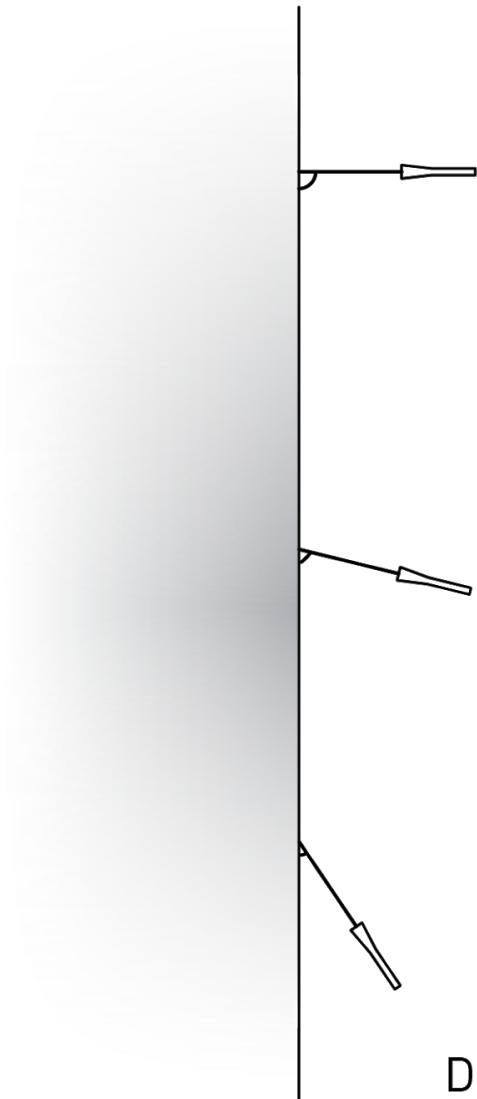

DIAGRAM 7

- The lighter the coats of mud and the less excess that is spread onto the wall, the less sanding will be required

## Mud Over Screw Holes

- Using a drywall knife, check the screw heads in the room to make sure that they are sunken far enough below the surface
  - Run the drywall knife over each screw head, if the knife contacts the screw head, it needs to be sunken further in
- First Coat
  - First coat should be applied during the tape coat of drywall seams (see below)
  - Apply mud to screw holes using a 4" or 5" knife
  - Clean off knife on mud tray and use clean knife to scrape off any excess mud
  - Less excess mud at this stage will result in less sanding
  - After mud dries, scrape off any excess mud with a clean knife
- Second coat
  - Second coat should be applied during the skim coat of drywall seams (see below)
  - Repeat process used for first coat
- Sand mud over screw holes while sanding the rest of the room (after all coats of mud are completed)

## Tape Coat of Mud

- Using paper tape
  - Use a 6" knife
  - Apply a coat of mud to the drywall, using method listed above (See Diagram 7)
  - Lay paper tape overtop of the mud, centered on the joint of the two drywall pieces
  - Clean knife off and use it to flatten out tape
    - Clean knife between each stroke
    - Flatten tape to remove all bubbles/air pockets
  - Tape should be slightly embedded into the mud so that they mud and tape create an even surface (See Diagram 8)
  - Allow mud to dry overnight

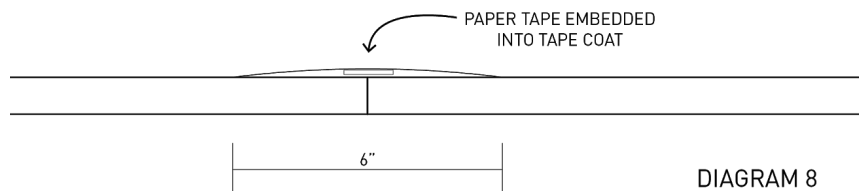
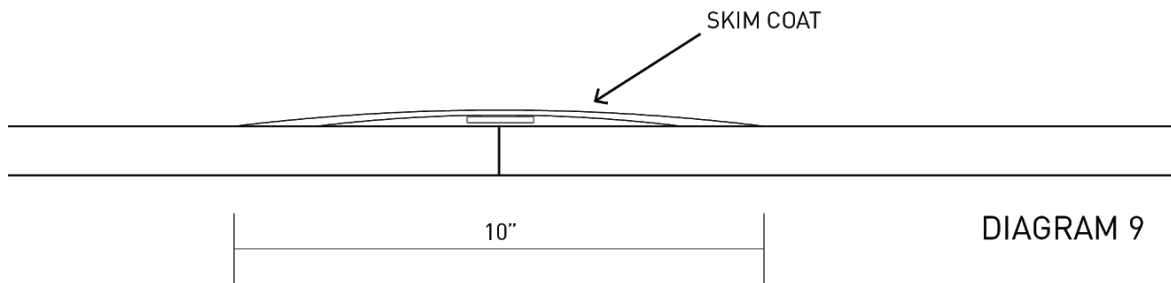

DIAGRAM 8

- Using mesh tape
  - Apply adhesive mesh tape to wall before applying any mud
  - Apply a thin coat of mud over top of the tape
    - The tape should still be seen through the mud
  - Allow to dry overnight
- After mud is mostly dry, use a wider knife, running it over the joint to knock off any ridges or excess of mud (this may have to wait until overnight)
- Inside Corners
  - Always use paper tape on inside corners
  - Apply a thin coat of mud to each side of the corner, using a 6" knife
  - Cut tape to length and pre-crease
  - Press the tape into the mud in the corner
  - After tape is in place, run a clean drywall knife down each side to embed the tape into the mud and work out any air pockets
  - Allow mud to dry overnight
- Outside Corners
  - Apply a thin coat of mud to each side of the corner
  - Run knife from top to bottom, holding at a 45° angle
  - One edge of the knife should rest on the outside of the corner bead and the other on the drywall
  - Scrape off any excess mud and clean any mud left on the ridge of the corner bead
  - Allow mud to dry overnight

### **Skim Coat of Mud** (See Diagram 9)

- Allow tape coat to dry completely before applying skim coat
- Scrape off any excess mud/ridges with a clean, wide knife before beginning the skim coat
- Skim coat will be the same regardless of what type of tape was used
- Use a 10" knife
- Apply a thin coat of mud
  - Tape should no longer be seen through this coat of mud
- Skim coat should be applied to both inside and outside corners
  - Inside corners can be completed using a inside corner tool (knife with a bend in it to apply mud to both sides at a time) if this tool is not available, mud one side of inside corner and let it dry before mudding the other side
- Allow mud to dry overnight
- Scrape off any excess mud/ridges with a clean, wide knife



### **Finish Coat of Mud** (See Diagram 10)

- Allow skim coat to dry completely before applying finish coat
- Scrape off any excess mud/ridges with a clean, wide knife before beginning the finish coat
- Finish coat will be the same regardless of what type of tape was used
- Use a 12" knife
- Apply a thin coat of mud, as flat as possible
- Allow mud to dry overnight

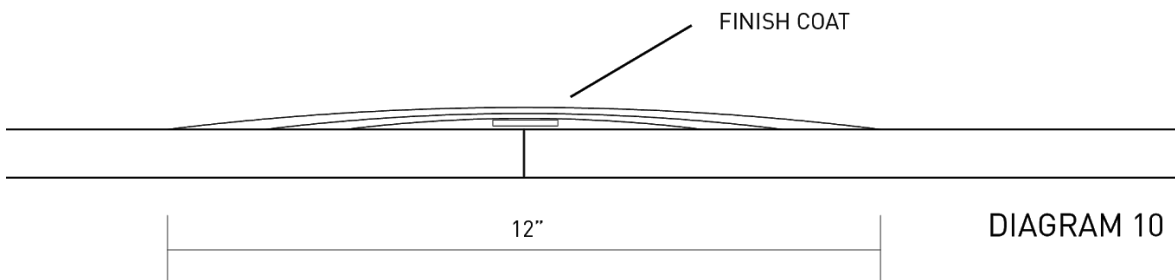

### **Sanding**

- Allow finish coat to dry completely before sanding
- Dust masks and eye protection should be worn while sanding
- 100 grit drywall sanding screens should be used
- Dried mud should be sanded where there are high spots, to make the wall flat
- Oversanding can result in low spots and even damage the tape that is air sealing the wall

## **Textured Drywall Finishing**

- Adding texture to drywall is an alternative way to complete drywall finishing and hides mistakes better than traditionally finished drywall
  - Drywall texture is most traditionally added only on the ceiling but can be added on walls
- Taping and sanding should still be completed as described above
- Rollers, sponges, or texture brushes can be used to create texture on the ceiling
  - Mud should be mixed with water to make it easier to work with
    - Mud should be mayonnaise consistency
  - Practice texture on a drywall scrap before applying to the ceiling
  - To use rollers for texture, mix mud with water and use a nappy roller to simply roll the mud evenly onto the drywall
  - To use sponges or brushes, mix mud with water and dip the sponge/brush into the mud and apply it to the drywall making an evenly spread texture/pattern across the drywall
- Textured drywall will require a longer time to dry depending on how thick mud is applied

## **Drywall Material List**

| <u>Quantity</u> | <u>Item</u>    | <u>Purpose/Notes</u>  |
|-----------------|----------------|---|
| ___ SF          | Drywall        | Determine thickness needed  |
| ___             | Corner Bead    | For outside corners of drywall  |
|                 | Drywall Nails  | For attaching corner bead   |
|                 | Drywall Mud    | Pre-mixed is a more user friendly product for less experienced volunteers |
|                 | Drywall Tape   |   |
|                 | 2x4 White Wood | For blocking/nailers and T-braces as needed                               |
|                 | Drywall Screws |   |
|                 | Sanding Screen |   |
|                 | 3" Screws      | For installing blocking/making T-braces if needed                         |

## **Recommended Tools**

### **Safety:**

Glasses  
Gloves  
Dust Masks

### **General:**

Basic Hand Tools (Tape measures, hammers, pencils, speed square, etc)  
Utility Knives + extra blades  
Saw Horses  
Extension Cords/Splitters  
Ladders  
T-Square  
Chalk Line  
Shop Vac/Broom and Dustpan  
Drop Cloths/Plastic - to cover furniture  
Tin Snips - to cut corner bead  
Fan - to help drying time  
Rags

### **Drywall Tools:**

Mud Trays  
Mud Knives (4" or 5", 6", 10", and 12")  
Corner Knife Tool  
Key Hole Saw  
Sanding Screen  
Sanding Blocks  
Drywall Rasp

### **Power Tools:**

Drill/Impact Driver  
→ Dimpler Bits  
→ Phillips Drivers  
→ T-25 Driver to match deck screws for blocking  
Circular Saw/Miter Saw - to cut blocking if needed





# Paint & Trim

## Painting/Priming

**Why paint?** Painting provides a cleanable surface, which helps create better air quality. Paint also protects surfaces from moisture and can have a positive affect on mood. A fresh coat of paint can be good for more than just the home.

### Safety

- **Any paint from before 1978 likely contains lead and CAN NOT be scraped/sanded**
- If there are pets or kids on the worksite block off work area or keep paint out of reach
- Use ladder safety on page 11
- Wear safety glasses when rolling paint onto ceilings

### Painting Project Planning

- Do walls/ceilings need any repair before painting?
- Will primer be needed?
- What sheen of paint will be appropriate?
- Will window/door trim/baseboard be painted as well?
- Clean the surface before painting
- Plan where furniture/belongings will be during the painting process, provide adequate drop cloths to cover anything that cannot be removed from the area
- How many ladders will be needed?
- Where is a good water source for cleaning brushes?
- If there are multiple types of paint (for ceilings/walls/trim/etc.) label what each is for
- Will paint cover stains or does drywall need to be replaced?
- What color does the homeowner want?
- Is the painted area sufficiently ventilated while working and while drying?

## **Measurements Needed**

- Surface area to be primed/painted (*Perimeter of room X Ceiling Height = Surface Area*)

## **Quality Control**

- Make sure paint is mixed well
- Are there any drips in the paint?
- Is paint spread evenly on the surface?
- Make sure edges around doors and the top/bottom of the wall are cut in with a brush, not a roller
- If brushes/rollers are not being used during a break – make sure they are cleaned or wrapped in plastic to keep them from drying out

## **Common Mistakes**

- Paint not mixed and color not the same across room
- Paint from roller not distributed well, visible difference in texture
- Brushes dry out/get tacky while left sitting out during breaks

## **After Work is Complete Quality Control Check**

- Is another coat needed?
- Do any surrounding surfaces need to be cleaned? Windows/trim/etc.
- Is all tape removed and outlet covers/switch plates back in place?
- Leave some leftover paint with homeowner for touch ups

# Priming and Painting

## Paint Information

- Paint is either interior or exterior, do not use exterior paint on interior surfaces and vice versa
- Paint can be latex based or oil based
  - Latex based paint should be used whenever possible, it dries quickly, cleans up with water, and has less of an odor
  - Oil based paint is more durable but takes longer to dry (up to 2 days), requires paint thinner for clean up (which can be difficult and hazardous), and has a strong odor
- Paint has different sheens, meaning how much gloss is in the paint
  - Higher sheens should be used in areas that will have more traffic, need to be cleaned more often, or experience more moisture
  - Different sheens and applications:
    - Flat: Ceilings
    - Eggshell: Bedrooms, Living Rooms
    - Satin: Kids Rooms, Kitchens, Laundry Rooms, Hallways
    - Semi Gloss: Baseboard/Trim, Doors, Cabinets

## Room Preparation

- Items in room
  - Move items away from walls, out of the room if possible
  - Coordinate with homeowners about items in room
  - Cover anything that cannot be removed, make sure that it is covered before painting begins
- Drop cloth
  - Make sure a drop cloth or plastic is put down to protect the flooring from paint drips
  - Plastic or dropcloths can easily be cut to size and taped to the baseboard to prevent a gap between the dropcloth and wall
- Remove outlet covers/switch plates/etc.
  - Place all pieces and screws in a certain location so that they can be replaced when the work is complete

## **Surface Preparation**

- All surfaces should be cleaned before they are painted
  - Drywall should be wiped down with a slightly damp rag
  - Metal surfaces, paneling, or other water resistant surfaces can be cleaned with wet rags and a basic cleaning solution
  - Allow all surfaces to dry before priming/painting
- Sweep/vacuum away any particles/dust close to the painting area that could get into the paint
- Fix any imperfections in the surface before painting
  - Any holes in drywall should be patched with mud/putty and allowed to dry
  - Any cracks in siding should be caulked and allowed to dry
- For paint that is flaky on surface to be repainted
  - If the paint is older than 1978 it likely contains lead and should not be scraped or sanded, work with staff/construction consultant/Home Repair Coordinator to find an alternate solution
  - If flaky paint does not contain lead, scrape it with a paint scraper or wire brush to knock all the loose pieces off
    - All existing paint does not need to be removed, but there should be a flat, clean surface before priming/painting

## **Taping**

- Taping is an important and tedious job that should occur before priming/painting begins
- Taping is done to protect adjacent surfaces that should not get paint on them
- If tape does not stick well, the area may not be clean
- Tape should be used on baseboard/trim, on ceilings, and any other adjoining surface that is not to be painted
  - Make sure that the tape is covering the surface that needs to be protected and not intruding on the area that is to be painted
- Tape should be pressed down well
- Do not remove tape until the primer/paint has dried completely

## Paint Brush Technique and Care

- Hold the paintbrush like a pencil for more control over where paint goes
- Dip only ½" - 1" of the end of the bristles into the paint at any time (See Diagram 1)
  - If paint gets any higher up on your brush it will gum up the paintbrush, dry and become messy and difficult to clean
- A paint brush should not sit with paint in it for more than 5 minutes
  - If you are taking a break or doing something else for a while, the paint brush can be set in clean water during that time
    - When you come back to the paintbrush, dry it out as much as possible with a cloth before beginning to use it again
  - If you are done with the paintbrush, wash it out immediately
    - The sooner the paintbrush is washed out the easier it will be to clean
  - Paint brushes should always be cleaned thoroughly, this is not a fast process
    - Clean until no more color comes out of the bristles under running water, even as you spread the bristles apart
    - A clean wire brush can be used to comb the bristles of the paint brush and work paint out of them

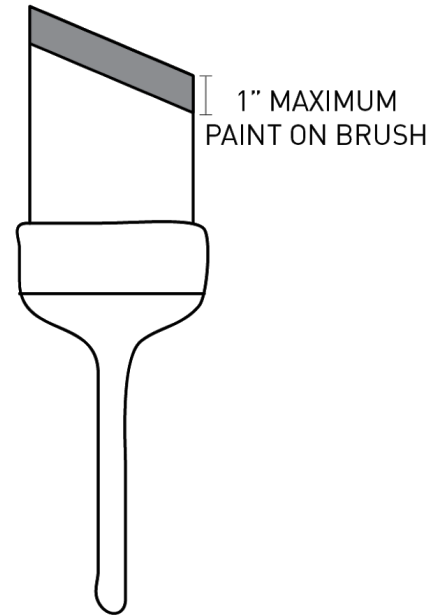

DIAGRAM 1

## Cutting In

- All borders of the surface being painted should be painted with a brush (See Diagram 2)
  - The cut in area should be about 6"-8"
  - Corners of adjoining walls, the top and bottom of walls, around windows and doors are all areas that should be cut in
  - If painting a ceiling, the perimeter of the wall touching ceiling and light fixtures should be taped
- A smaller, angled brush (1 ½" or 2") is good for cutting in
- Dip no more than 1" of the paint brush into the paint at any time
- Run a line of paint onto the wall about 1" away from the edge, go back to the top of that line and run the brush down, applying enough pressure to spread out the bristles and let them run directly down that edge (See Diagram 3)
  - Go back and smooth out the extra paint with the paint brush so that no bumps are left in the paint
  - This method works best in 2'-3' increments

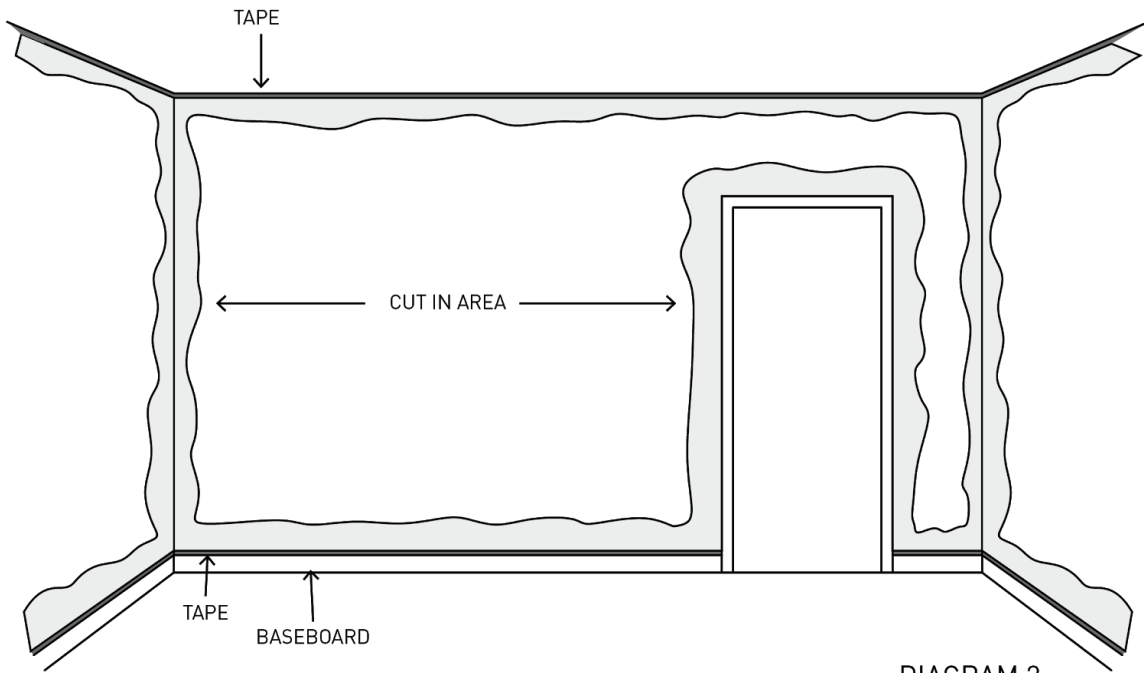

DIAGRAM 2

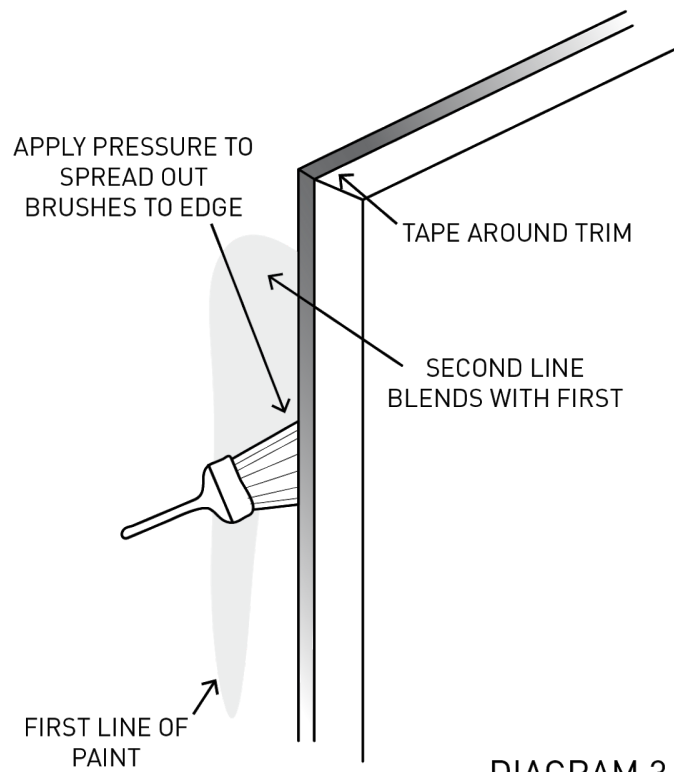

DIAGRAM 3

## Roller Technique and Care

- Paint trays should not contain so much paint that there is not space to even out the paint on the roller using the ramp on the tray
- To load paint onto the roller:
  - Dip the roller ½" into the tray
  - Roll up and down the ramp on the roller tray to distribute paint evenly
  - Repeat this several times until the roller is covered with paint, but not dripping
  - If a roller throws paint off as it rolls against the wall, it is overloaded
- To apply paint to surface: (See Diagram 4)
  - Start 6" from a corner and 12" above the floor
  - Roll up towards the ceiling at an angle away from the corner, applying little pressure
  - Stop a few inches shy of the ceiling, and roll straight down to distribute the paint rolled on by the first stroke
  - Repeat this process until the majority of the paint is off of the roller, then go back over the painted area with a mostly empty roller to distribute paint more evenly
  - Work across the wall in this manner
  - Periodically, go back over the painted area with a mostly empty roller, using the same strokes with light pressure to even out any roller marks
  - With a mostly empty roller, run the roller horizontally across the top and bottom of the wall to even out strokes made that overlap the cut in area
  - In Diagram 4, the smaller arrows show the passes already made with the roller and the larger arrows show the continuing path to follow with the roller

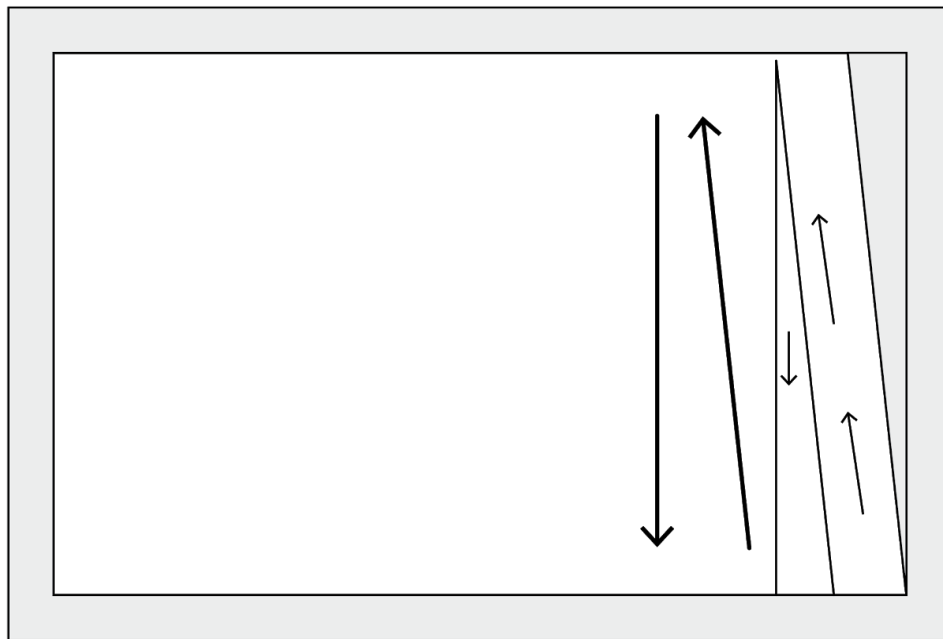

DIAGRAM 4

- The roller cover can be sealed in a plastic bag and saved so that it does not dry out between coats of paint
- Roller covers should be washed thoroughly after use
  - Scrapers can be used to squeeze excess paint out
  - Clean in running water or in buckets of water, swapping out for clean water occasionally
  - Clean until water runs clear out of roller

## **Painting Trim**

- Trim should be painted before installation if possible
- Pre-primed trim only needs to be painted, trim that is not pre-primed needs to be primed and painted
- Small rollers can be used to paint baseboard/1x4
- If painting must be done after trim is installed, tape both the floor and the wall

## **Priming/Painting Material List**

| <u>Quantity</u> | <u>Item</u>  | <u>Purpose/Notes</u>   |
|-----------------|--------------|--|
| —               | Primer/Paint | Account for how many coats of paint/primer should be needed for the area to be painted |
|                 | Paint Tape   |  |

## **Recommended Tools**

### **Safety:**

Glasses - should be worn when rolling overhead

### **General:**

Basic Hand Tools (Tape measures, hammers, pencils, speed square, etc)

Ladders

Buckets or Hose - for cleaning out brushes/rollers

### **Paint Tools:**

Paint Brushes (1 ½" - 3")

Paint Cups

Stir Sticks

Drop Cloths/Plastic/Housewrap

Rollers

Roller Covers

Paint Trays/Liners

Stir Sticks

Rags

Cleaner



# Trim/Moulding

**Why trim?** Trim covers and protects the edges of the flooring, helps air seal around exterior doors, and helps provide a finished product.

## Safety

- Wear eye protection while cutting with a miter saw

## Trim Project Planning

- What type of trim will be used?
- Can trim be painted outside before it is installed?
- Wall painting should be done before trim is installed

## Measurements Needed

- What lengths of trim will be needed?
- Will quarter round or base shoe be needed to cover the gap around the flooring?

## Quality Control

- Are corners mitered?
- Is trim spliced correctly over long walls of the room?
- Are holes pre-drilled before finish nails are installed?
- Are nails going into studs of the wall?
- Make sure nail heads countersunk below surface (using nail punch) and filled in with putty

## Common Mistakes

- Corners just butted together (this is only correct for 1x4)
- Pieces of trim butted straight together over long walls (not spliced at angles)
- Nails installed without pre-drilling causing trim to split
- Nails only going into drywall
- Nail heads just hammered flat to surface and no nail punch used

## After Work is Complete Quality Control Check

- Is trim caulked?
- Does baseboard cover edges of flooring?
- Is trim fastened well (into studs)?
- Are fastener holes filled with caulk or putty?

## Types of Trim

Baseboard (5-A)

Base Shoe (5-B)

Quarter Round (5-C)

Casing (5-D)

1x4 (5-E)

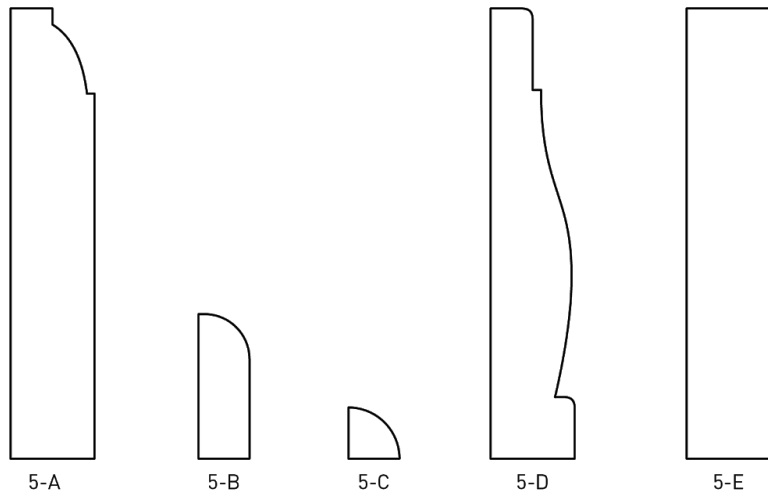

DIAGRAM 5

## Preparation and Working with Trim

- Trim can be primed/painted before it is installed and then touched up after installation
- Mark the studs on the wall (paint tape can be used for this)
- All trim should be cut with a miter saw
- Door Casing should be installed before baseboard as it will run all the way to the floor, baseboard will then butt into that

## Corners (Baseboard, 1x4, Ceiling Molding, Base Shoe, Quarter Round)

- The same methods will be used for baseboard (base or 1x4) and 1x4 ceiling molding
- Mitered Corners
  - For baseboard, base shoe, or quarter round all corners should be mitered so that the profiles of the trim meet at the corner
  - If possible cut the angle on one end of the piece and hold it in place, then make the mark for the cut at the opposite end (this eliminates error from using a tape measure)

- **Outside corners:** (See Diagram 6)
  - The joint where two pieces come together may need to be greater than 45° if the corner is not completely true
    - Scraps can be used to practice and determine needed angles

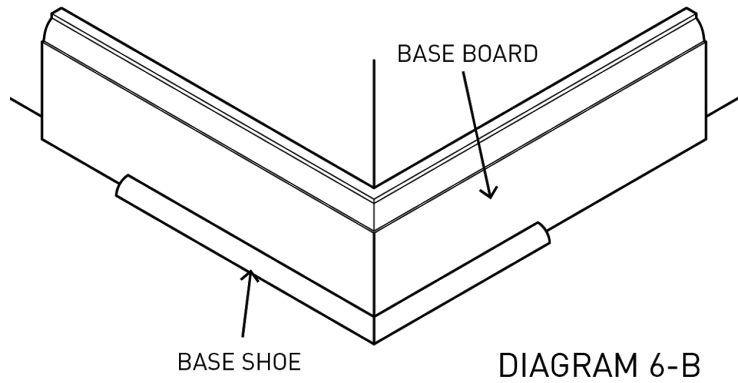
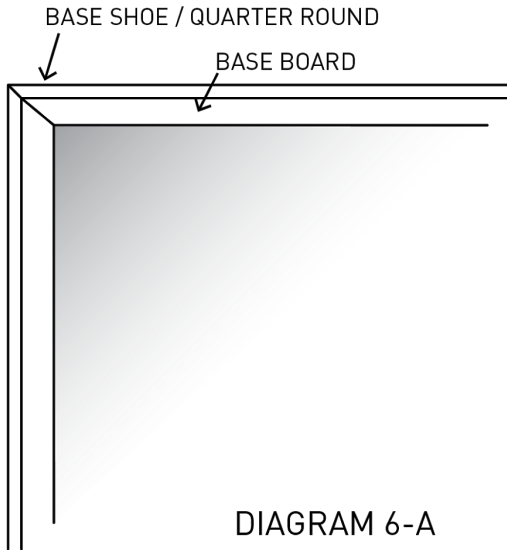

- **Inside Corners:** (See Diagram 7)
  - Where the two pieces come together, a 45° should be cut on the end of both pieces

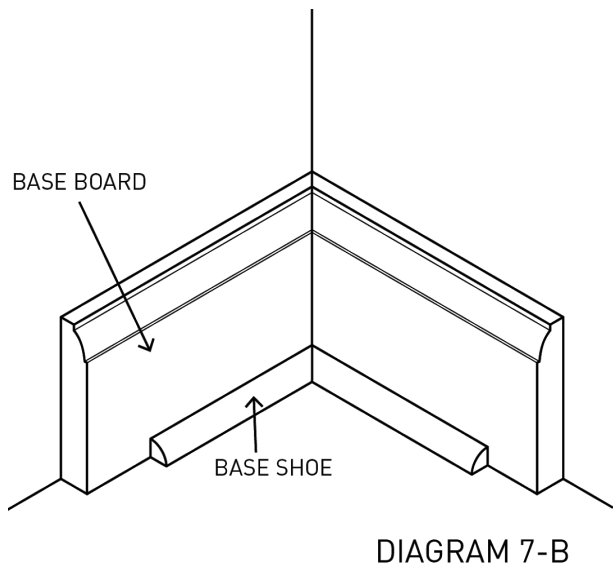
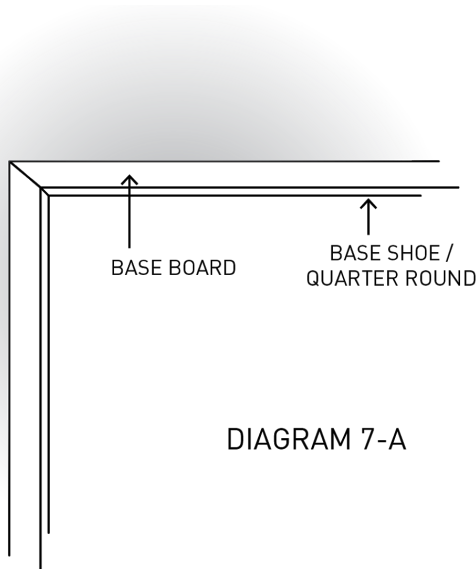

- Non-Mitered Corners

- If 1x4 material is used for baseboard, it does not have to be mitered
- **Outside Corners:** (See Diagram 8)
  - The piece coming from one side should run even with the corner of the wall
  - The piece coming from the other side should run to even with the outside of the first piece of 1x4

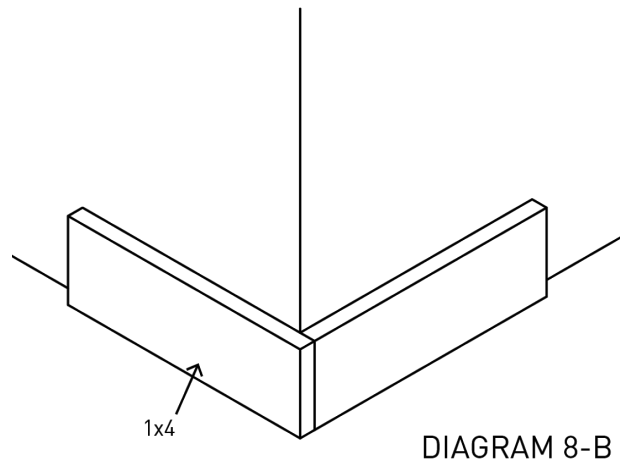
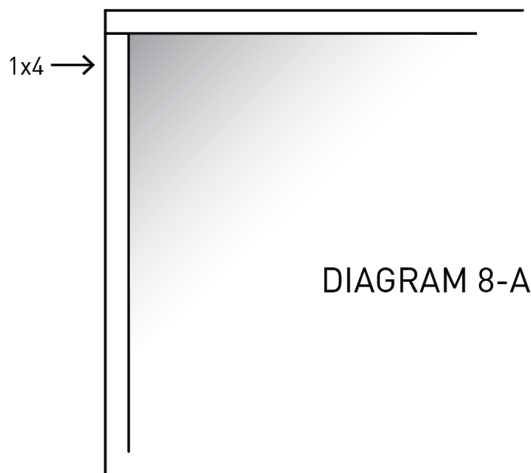

- **Inside Corners:** (See Diagram 9)

- The piece coming from one side will run all the way into the corner
- The piece coming from the other side will run directly into the first piece

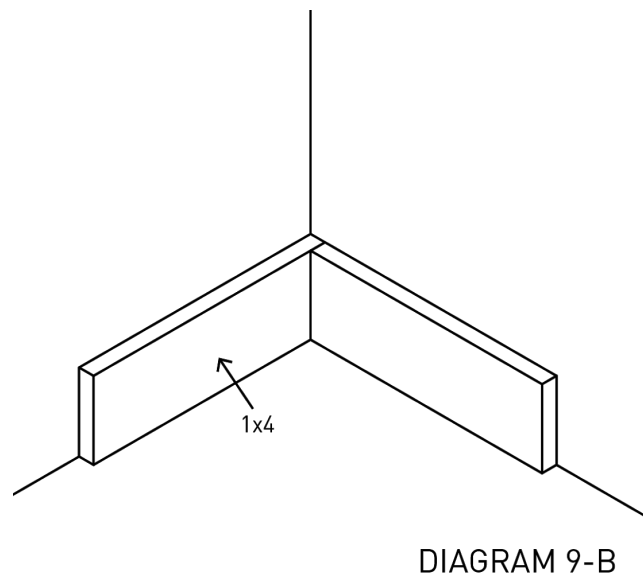
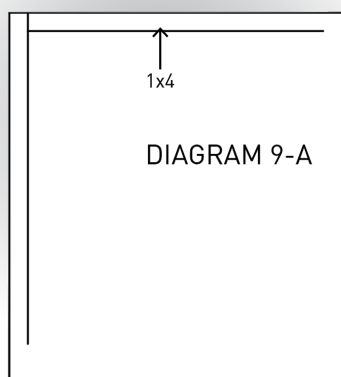

## **Base Shoe and Quarter Round**

- Base shoe or quarter round can be installed over baseboard
- Base shoe and quarter round protect the bottom of the baseboard
- Base shoe or quarter round can also be installed to cover the edges of the flooring if the baseboard is not wide enough to do so
- Where base shoe or quarter round meets door casing, base shoe/quarter round will extend past the width door casing
  - At these points, cut the base shoe or quarter should be cut at 22.5° (See Diagram 10)

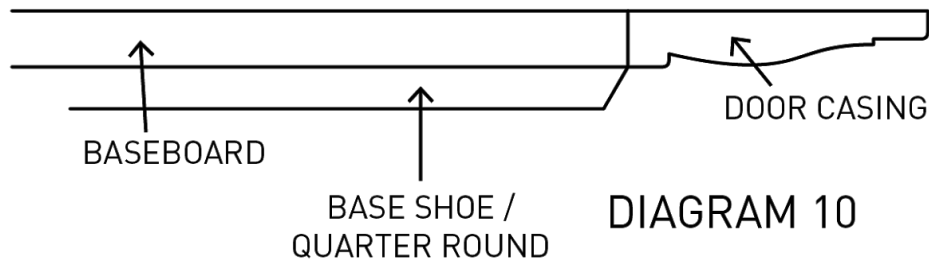

## **Splices** (See Diagram 11)

- A splice is where two pieces of trim will come together over a long wall
- Try and use long/full pieces to avoid splices
  - Some splices will be inevitable because of the size of the room
- Splices should occur over a stud
- Cut a 30° splice into each piece so they will fit tightly together
- If 1x4s are using the ends can butt straight together, without the angled splice, but should still meet over a stud

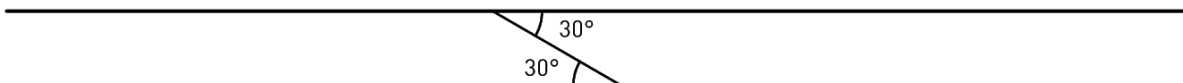

DIAGRAM 11

## Fastening Pieces

- 6d finishing nails or trim screws (typically have a T-10 head) should be used to install trim
- Holes should be pre-drilled before nailing to prevent splitting
  - Drill bits this small will break easily, do not apply a lot of pressure on drill or bend the bit
  - Use a drill bit slightly smaller than the diameter of the finish nail
- Hammer nail until the head is almost flush, then use a nail punch to finish setting the nail to just below the surface of the trim (See Diagram 12)
- Baseboard or 1x4 should be fastened into the studs of the wall
  - Do not nail into the floor
- Base Shoe/Quarter Round should be fastened into the baseboard

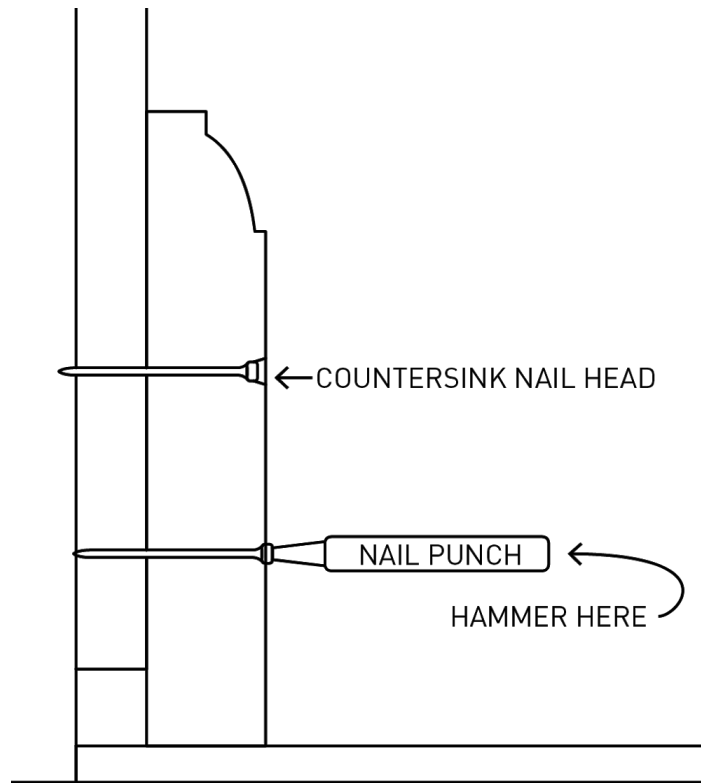

DIAGRAM 12

## Casing (Doors) (See Diagram 13)

- Pieces of door casing will be installed around the perimeter of the door,, leaving a small reveal of the door jamb
- At the top corners of the door, pieces will be cut at 45° to make mitered corners
- Install the top piece, then the two side pieces
- Side pieces will run all the way down to the floor covering
- See fastening instructions below

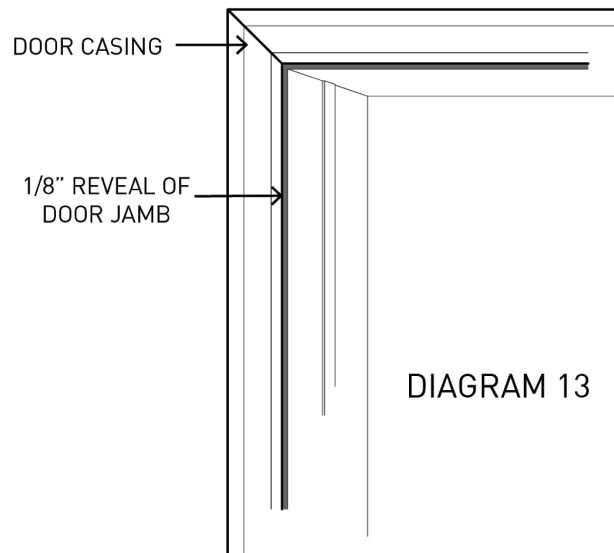

DIAGRAM 13

## Casing (Windows)

- Pieces of drywall or 1x material will be used to finish the inside of the rough opening for a window
- Casing should be used around the perimeter of the window
- All pieces will be cut at 45° to make mitered corners
- Start with with the top piece and work down when installing
- See fastening instructions below

## Fastening Casing

- 6d finishing nails or trim screws should be used to install casing
- Holes should be pre-drilled before nailing to prevent splitting
  - Drill bits this small will break easily, do not apply a lot of pressure on drill or bend the bit
  - Use a drill bit slightly smaller than the diameter of the finish nail
- Hammer nail in until head is almost flush, then use a nail punch to finish setting the nail to just below the surface of the trim (See Diagram 13)
- Casing will be fastened into the rough opening frame of the door/window

## Caulking (See Diagram 14)

- White, acrylic, paintable latex caulk should be used for caulking trim
- Cut ¼" off the tip of the caulk gun with the built in tool on the handle or with a utility knife
- Use the poking tool or a long nail to pierce the seal of the tube
- Where to caulk:
  - Seams between wall and baseboard/casing
  - Seams between baseboard and base shoe/quarter round
  - Corner joints of all trim
  - Divots from nails/screws

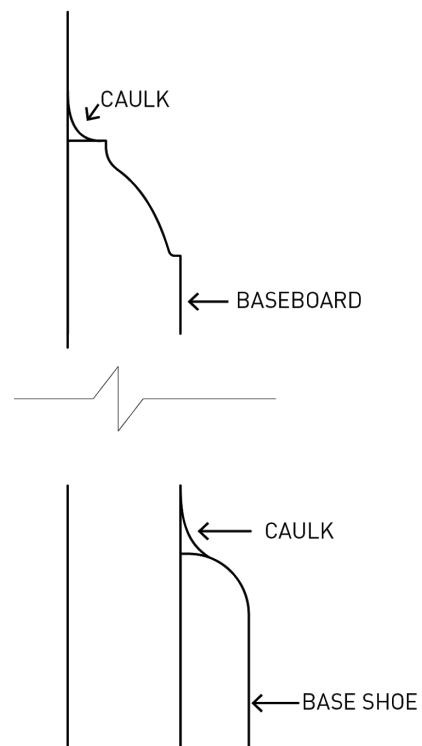

DIAGRAM 14

- How to caulk:
  - Hold the caulk gun at a 45°, with the top of the cut tip in the intersections where the caulk will be applied
  - Apply light and consistent pressure to the handle while moving the caulk gun across the seam
  - If needed smooth out the seam using your finger, clean finger off on a rag as caulk builds up on it
- Use wet rags to clean up any drips or wipe off tip of caulk gun as needed
- Add a small amount of caulk to all divots created by countersinking nail/screw heads to make them invisible
- After caulk dries, any imperfections can be touched up with the original baseboard paint
- Put a long nail or screw in the tip of the caulk to seal it when done caulking

## **Trim Material List**

| <u>Quantity</u> | <u>Item</u>     | <u>Purpose/Notes</u>      |
|-----------------|-----------------|---------------------------|
| —               | Trim            | (Baseboard, casing, etc.) |
|                 | 6d Finish Nails |                           |
|                 | Caulk           | Acrylic, latex paintable  |

## **Recommended Tools**

### **Safety:**

Glasses

### **Power Tools:**

Miter Saw

Drill

→ Drill Bit to pre-drill for finish nails

### **General:**

Basic Hand Tools (Tape measures, hammers, pencils, speed square, etc)

Step Ladders - for tops of doors/windows or ceiling trim

Nail Punch

Saw Horses

Extension Cords

Caulk Gun





# Drainage & Gutters

## Positive Drainage

Positive drainage is created by making a slope that runs away from the house.

- Positive drainage is a lower maintenance alternative to gutters, which can cause damage if they are not cleaned out regularly or installed incorrectly
- Moving soil with hand tools can adjust grade to provide drainage. It is recommended to have a minimum of 6 inches of fall within the first 10 feet of a home.
- If this is not possible due to location of home, other methods to provide drainage must be used.

## Drainage Ditches

Why drainage ditches? Drainage ditches help re-route water that normally accumulates around the foundation of the home. They help reduce moisture build up (that can cause mold and rot) under and at the base of the home. There are two basic types of drainage ditches.

- Surface Drainage. Typically a shallow ditch dug and filled with gravel to allow a pathway for surface water to drain away from home. These are the most typical ditches we use to redirect water.
- Subsurface Drainage. Also referred to as a French drain. Subsurface drains are placed beneath the top layer of soil to remove excess water at the root level. Subsurface drains are often deeper and require drainage pipe, filter fabric, in addition to gravel.

## **Safety**

- Be cautious of underground utilities while digging
- When working closely together, be careful while swinging pickaxes/dig bars
- Gravel can be heavy, do not over lift
- Straw can be used to make the walking surface less slick if needed

## **Drainage Ditch Project Planning**

- Where will the ditch be? Where will water be diverted to?
- Is it surface water or ground water that needs to be diverted?
- Are there any underground utilities in the area that the ditch will go?
- Where will you drop off gravel when it is delivered?
- How much gravel will be needed? Should you get it delivered?
- Make sure there are enough digging tools and wheelbarrows available
- Will there be enough work to keep people busy while waiting for gravel deliveries?

## **Measurements Needed**

- Length of ditch
- Width and depth of ditch

## **Quality Control**

- Check the slope of the ditch
- Check that the ditch is at least 6" deep and 12" wide for a surface drainage ditch (Should be at least 10" for a subsurface drainage ditch)
- 

## **Common Mistakes**

- The ditch is not sloping enough to drain water
- Filter fabric not wrapped complete around gravel

## **After Work is Complete Quality Control Check**

- Has there been grass seed and straw applied to disturbed dirt?
- Is the ditch diverting water away from the house? Make sure that water is not directed towards anywhere that it could cause damage
- Make sure ditch is full and slightly mounded with gravel

## Drainage Ditch Instructions

### Plan Ditch (See Diagram 2)

- Plan the path of the ditch before starting to dig
- The ditch should run perpendicular to the water flow, to catch and reroute water running downhill
- Determine the end point of the ditch
  - The ditch should not route water into someone else's yard
  - The ditch should end somewhere that it will not create additional water running across a driveway/walkway/yard
- The ditch must be at least 2' away from the foundation of the home
- Use marking paint to show the path of the ditch
- Designate where the highest point of the ditch will be

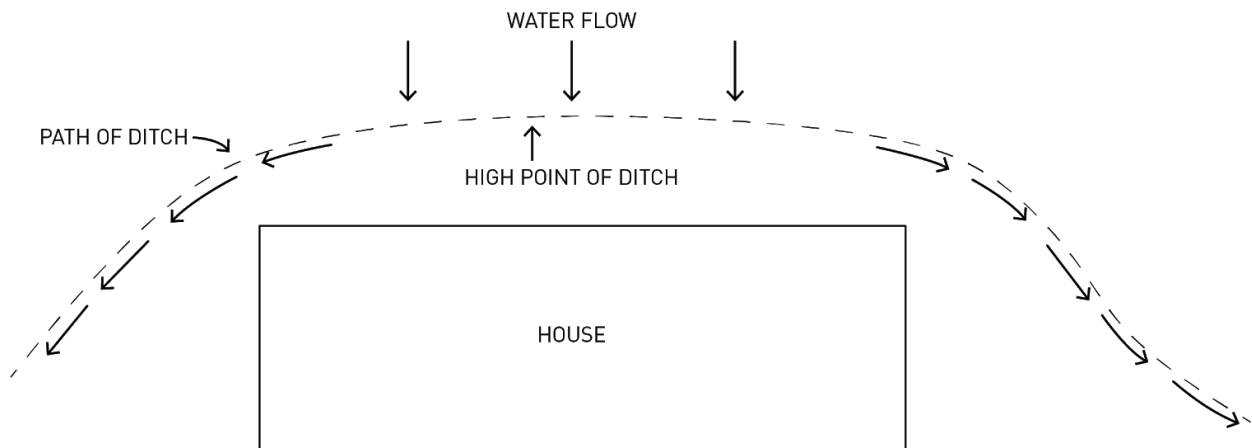

DIAGRAM 2

### Dig Ditch

- The **minimum** slope of the drainage ditch is a 1" drop for every 10' of length
  - To measure this, build a frame out of a 5' 2x4 piece at the top and legs on either end with one leg  $\frac{1}{2}$ " longer than the other (See Diagram 3)
    - A  $\frac{1}{2}$ " drop over 5' gives the required 1" drop over 10'
    - A level can be placed on top of the frame, when the frame is level that means the ditch is at the correct slope

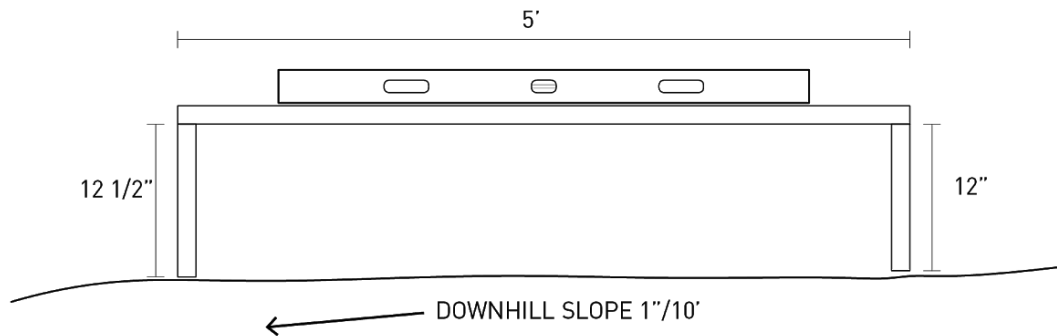

DIAGRAM 3

- The minimum size of a surface ditch is 12" wide and 6" deep (See Diagram 4)
- The minimum size of a subsurface ditch is 12" wide and 8" deep (See Diagram)
  - The ditch can be larger
  - The ditch will be deeper in some cases in order to meet the slope requirements
- Pile excess dirt from the ditch on the downhill side of the ditch (See Diagram 4)

### Fill Ditch

- When the ditch is completed:
  - Surface ditch:
    - Fill ditch with gravel (See Diagram 4)
    - #57 stone should be used
    - Gravel should fill the entire ditch and be slightly mounded so that dirt does not collect on top of the gravel
    - Spread grass seed and straw on disturbed portions of yard.

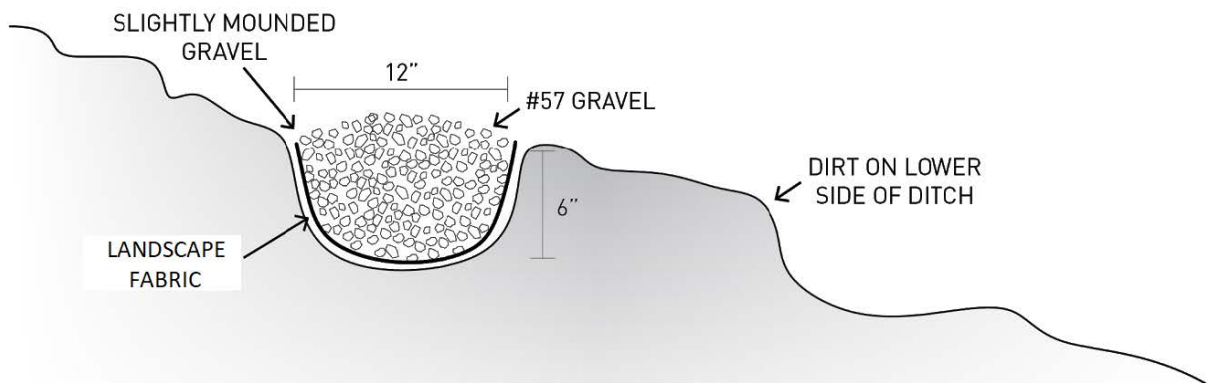
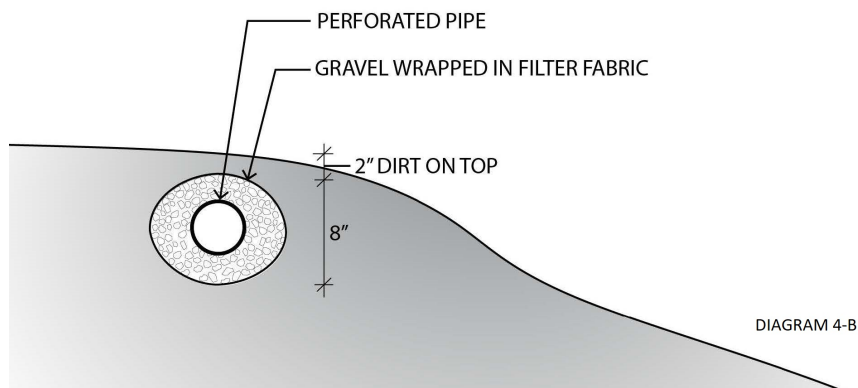

DIAGRAM 4

- Subsurface ditch: (See Diagram 4-B)
  - Lay filter fabric across across ditch with enough excess to fold back over top after ditch is filled with gravel
  - Place roughly 2-3" of gravel in bottom of ditch on top of filter paper
  - Place corrugated pipe in ditch being sure that it maintains at least 1" of drop for every 10' of pipe.
  - Once pipe is in ditch, cover and fill ditch roughly 2" to the top with gravel
  - Wrap filter fabric over top of gravel, hold in place with landscaping staples
  - Fill remainder of ditch with excavated dirt. Spread grass seed and straw to encourage new grass growth.



## **Drainage Ditch Material List**

| <u>Quantity</u> | <u>Item</u>            | <u>Purpose/Notes</u>   |
|-----------------|------------------------|--|
| —               | #57 Gravel             | Ordered by the ton<br>→ <i>Depth (in feet) X Width(in feet) X Length(in feet)=Cubic Feet</i><br>→ <i>Cubic Feet/27 (# of Cubic Feet in a Cubic Yard) = Cubic Yards</i><br>→ <i>Cubic Yards to Tons</i><br><i>Cubic Yards x 1.4 = Tons Needed</i> |
|                 | Membrane               | Landscape Fabric for lining ditch  |
| 1               | 2x4x10 WW<br>3" Screws | To build frame that measures slope<br>To build above frame<br>*corrugated pipe if subsurface drain is called for   |

## **Recommended Tools**

### **Safety:**

Glasses  
Gloves

### **General:**

Basic Hand Tools (Tape measures, hammers, pencils, speed square, etc)  
Utility Knives - to trim membrane  
Saw Horses  
Extension Cords  
Level (2' or 4')  
T-25 drivers to match screws

### **Power Tools:** (for building frame)

Circular Saw/Miter Saw  
Drill

### **Digging Tools:**

Shovels  
Digging Bar  
Pick Axe  
Wheelbarrow  
Buckets

# Gutters

**Why gutters?** Gutters are used to divert water that would otherwise accumulate at the base of the house and lead to mold or rot.

## Safety

- When working from ladders, do not rest ladders on gutter pieces that are not completely attached
- Edges of gutter can be sharp, wear gloves when installing
- Use ladder safety on page 9

## Gutter Project Planning

- **Does homeowner have the means to clean out the gutters on a regular basis? If not, positive drainage should be used instead of gutters**
- Make sure that fascia boards are in good condition before gutters are installed
- Is there drip edge or does the roofing material overhang the fascia to allow water to run into the gutter?

## Measurements Needed

- Length needed for gutter
- Height needed for downspouts
- Count connections, end caps, elbows, downspout assemblies, etc.

## Quality Control

- Make sure that gutter is underneath drip edge
- Make sure that gutter drops  $\frac{1}{2}$ " for every 10'
- Make sure that gutter drops towards the downspout
- Make sure downspouts are adequately fastened to gutter at top and home down the wall
- Gutter installed on outside of drip edge
- Gutter not appropriately sloped to downspout to drain, and just holds water
- Downspout not fastened to downspout assembly, falls out of place easily

## Common Mistakes

### After Work is Complete Quality Control Check

- Make sure that slip joints/downspout assemblies are caulked
- Make sure that all gutter and downspout pieces are attached well
- Make sure homeowner knows the importance of cleaning out gutters

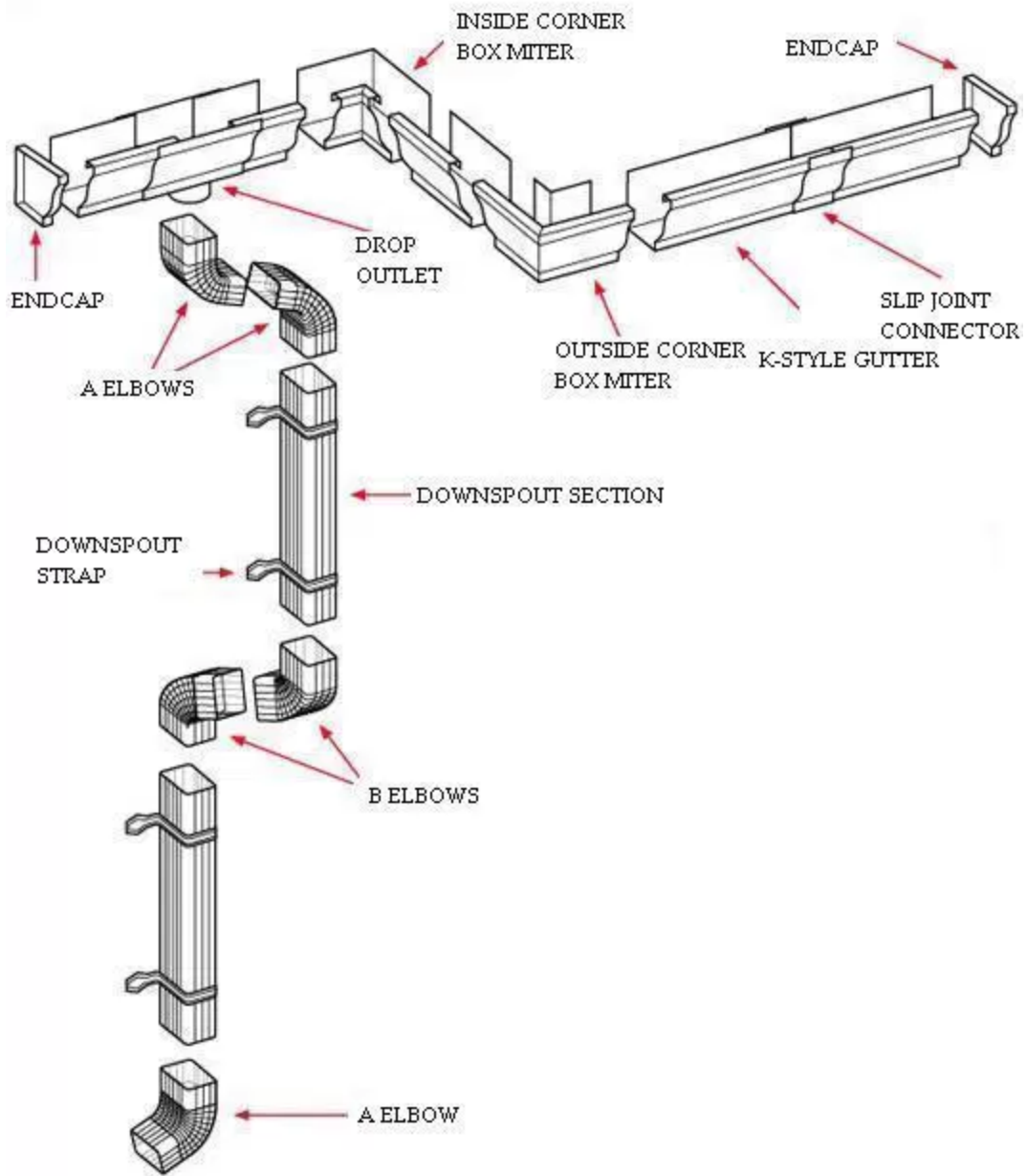

Diagram 11



- If the side of the home is under 35' the gutter will slope in one direction with a downspout at the low end
- If the side of the house is 35' or longer then the gutter will have a high spot in the middle and slope in two directions with a downspout at both ends
- For every 10', guttering should drop ½"
- Pull a chalk line across the fascia board of the house (use this to mark the bottom of the gutter)
  - For less than 35' lengths, start at one end
  - For 35' lengths or greater, start in the middle and work in both directions
  - The top of the gutter needs to sit behind the drip edge of the house in order to be effective, check this as the lines are snapped
- Start at the high point, slide gutter pieces behind drip edge and line up the bottom with the snapped chalk line
  - Attach the gutter using gutter hangers every 3'
- Where sections of gutters meet, use a slip connector and slide gutter into both sides
  - Use two fasteners into each side of the connector (in the front, through the gutter and connector)
  - Use rivets or ½" self tapping metal "gutter" screws
- Where pieces of gutter/downspout assemblies come together, all seams should be caulked with gutter sealant
- End caps should be installed on both ends of the gutter with gutter sealant
- Downspouts should be installed: (See Diagrams 12 and 13)
  - On the low end for sections under 35' or on both ends for sections 35' or over with a high point in the middle
  - Elbows should be used from the downspout assembly to bring the downspout close to the wall
  - Elbows and downspout pieces should be attached with rivets or ½" self tapping sheet metal screws
  - Use downspout straps to hold the downspout to the house
    - Straps should be fastened into the house before downspout is in place
    - Straps should be wrapped around the downspout and then a rivet or gutter screw should be used to fasten through both ends of the strap and into the downspout
- Elbows at the bottom should be used to angle the water away from the house, attached with rivets/screws (See Diagram 12)
- Splash blocks should be placed at the bottom of each downspout to route water away from the base of the house (See Diagram 12)

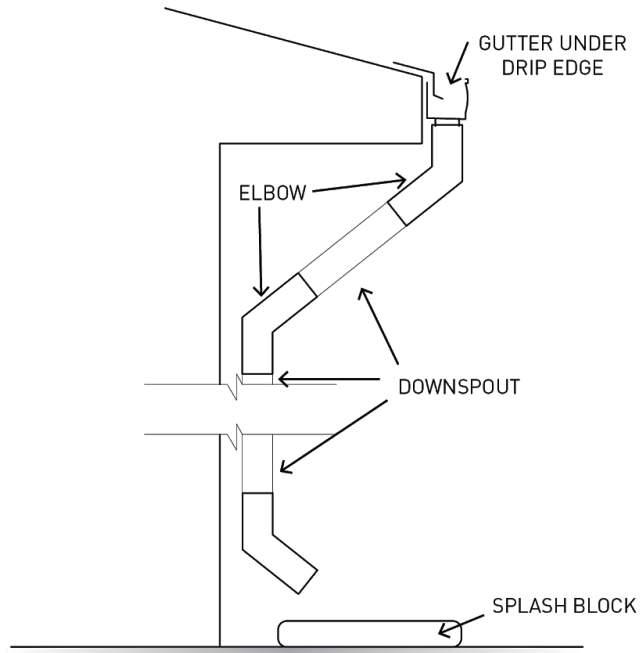

DIAGRAM 12

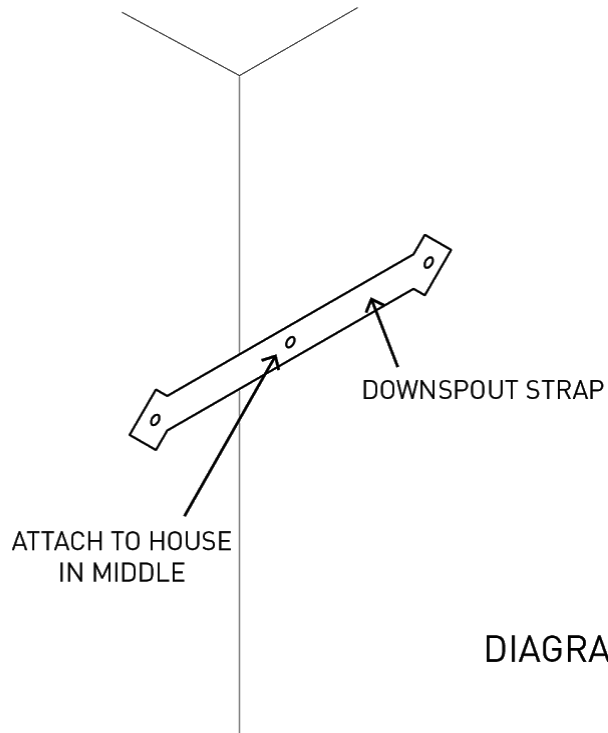

DIAGRAM 13-A

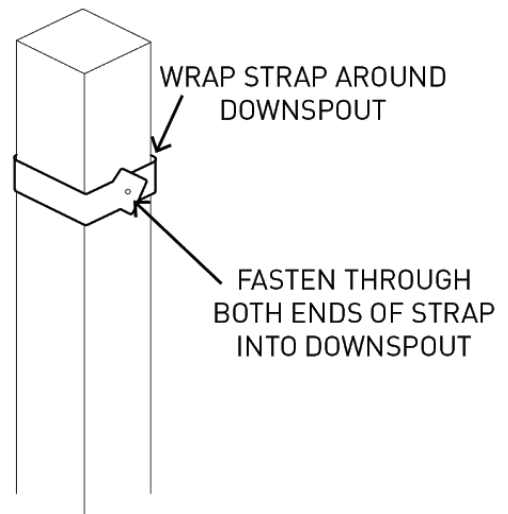

DIAGRAM 13-B

## **Gutter Material List**

| <u>Quantity</u> | <u>Item</u>               | <u>Purpose/Notes</u> |
|-----------------|---------------------------|----------------------|
| ___             | Gutter Sections           |                      |
| ___             | Slip Joint Connectors     |                      |
| ___             | Gutter Hangers            | Have ¼" Hex Heads    |
| ___             | Gutter End Caps           |                      |
| ___             | Downspouts                |                      |
| ___             | A - Elbows                |                      |
| ___             | B - Elbows                |                      |
| ___             | Downspout Assembly        | (or "Drop Outlet")   |
| ___             | Downspout Straps          |                      |
| ___             | Splash Blocks             |                      |
| ___             | Gutter Caulk              |                      |
| ___             | Gutter Screws (or Rivets) |                      |

## **Recommended Tools**

### **Safety:**

Gloves  
Glasses

### **General:**

Basic Hand Tools (Tape measures, hammers, pencils, speed square, etc)  
Level  
Chalk Line  
Tin Snips  
Caulk Gun  
Ladders

### **Power Tools:**

Drill/Impact Driver  
→ ¼" Hex Driver  
→ Phillips Driver





# Underpinning/Skirting

**Why underpinning?** Underpinning protects the crawlspace by providing insulation to the water lines below, keeping animals out, protecting insulation, and rerouting water/drainage that would otherwise be under the home.

## Safety

- Wear thick leather gloves, safety glasses, and ear protection when cutting rebar or metal with a power saw/grinder
- Both vinyl and metal are very sharp - use gloves while working with these materials
- Avoid putting rebar stakes through utilities/lines that may be underground
- Be aware of any bees/snakes/other critters that could be under the home

## Underpinning Project Planning

- Are there any obstacles around the home? How will you work around those? (AC/furnace units, gas tanks, porches, etc.)
- Where will access doors be needed?
  - Will they interfere with future projects? (ramps/porches/additions)
- How tall will the underpinning be? Will any additional framing be required?
- Provide a method for cutting rebar or purchase precut rebar.
- Will the crawl space be insulated? it may be easier to insulate before the underpinning limits access
- Why replacing?
  - Did weed eater destroy old vinyl? (if so, replace with metal not vinyl or same thing may occur)
- Color of tin the homeowner wants? (if applicable)

## Measurements Needed

- Measure perimeter of home and height off the ground at all corners
- Measure height at locations of access doors
- How many inside/outside corners are needed?

- Measuring for metal underpinning:
  - Metal sheets will be 3' wide, lay a tape measure across the ground and take vertical measurements at 3' increments (if there is a slope, measure higher side)
  - Add 3"-4" of height to each piece that will stick into trench in front of base plate
  - Consider getting a few extra pieces of metal in case of any mis-cuts around hitches/other obstacles
  - Keep a detailed diagram showing where each piece goes during installation

### **Quality Control**

- Make sure top plate is set back 1 ½"
- Make sure that bottom plate is installed directly below top plate
- Make sure bottom plate is secured adequately with rebar
- Make sure vertical studs are installed every 4' and that they are plumb (if applicable)
- Make sure vinyl pieces lock together
- Make sure pieces are plumb as they are being installed
- Measure each piece individually (vertically)
- Make sure vented pieces are installed (if applicable)

### **Common Mistakes**

- Underpinning sticking out further than siding
- Plumb bob not used to set bottom plate
- Pieces inserted into the J-channel at the top but not snapped into each other
- Pieces at a visible angle
- Pieces cut too short and not 2"-3" stuck into the ground
- No venting

### **After Work is Complete Quality Control Check**

- Is there positive drainage away from the underpinning?
- Is there adequate venting?
- Are pieces fastened well?
- Are tops of corner pieces covered/flashed well?
- Are crawl space doors installed and sealed well?

### **Group Leader Tips**

- Someone can start cutting rebar into 1' sections while others are start on the top plate
- Once the first several feet of top plate is installed, other volunteers can start coming behind installing the bottom plate
- After several feet of the top/bottom plate are installed, vertical members can be installed
- After sections of the vertical framing members are installed, vinyl corners and J-channel can be installed (if using vinyl)
- Vinyl sheets can be installed after the initial vinyl trim is started
- Create an assembly line around the house so that teams can specialize in one task

# Instructions for Vinyl Underpinning

## Prepare for Underpinning Installation

- Remove any old underpinning and any other items around the base of the home
- There needs to be a fairly flat surface to attach the top plate to, if necessary, trim back the chip board that is holding up the insulation about 4-5"

## Install the 2x4 Top Plate

- The top plate will be installed with the 3 1/2" side of the 2x4 against the floor joists (See Diagram 1)
- The outside edge of the top plate will rest 1 1/2" back from the edge of the band joist (See Diagram 1)
- Attach to the floor joists with 3" screws

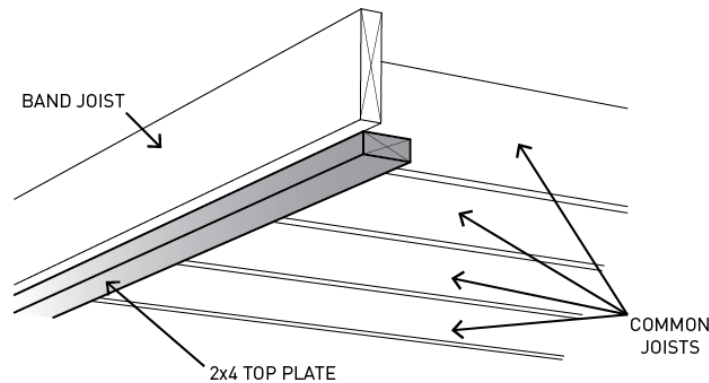
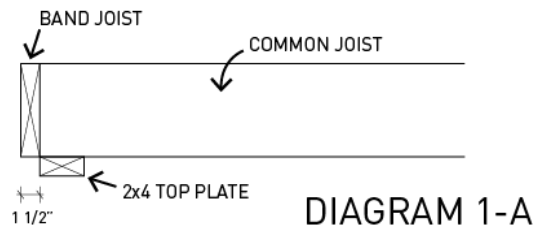

- Make sure that pieces of top plate meet on a floor joist so that there is something adequate for them to be attached to (See Diagram 2)

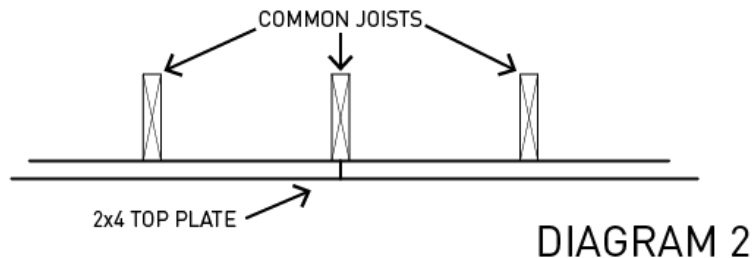

- On the long sides of mobile homes there will likely be outriggers (metal supports from the main beam) that interrupt the ability to continuously run the top plate
  - When these are encountered, run the top plate to either side of the outrigger and install a block attached to inside of band joist, level with the bottom of the band joist, to attach the top plate to if necessary (See Diagram 3 and 4)

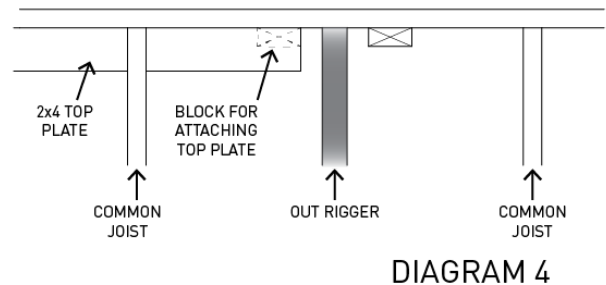
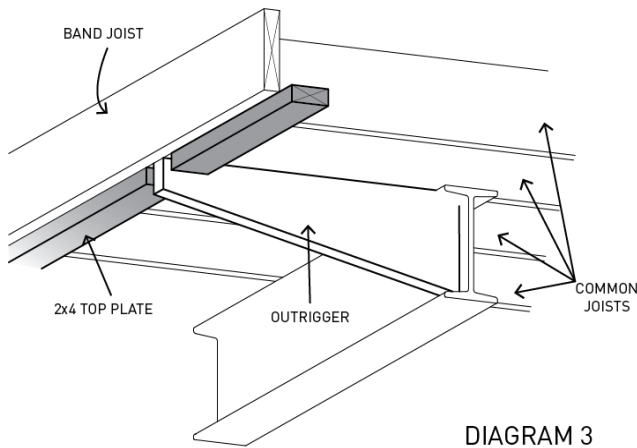

- The metal cross member across short ends of a mobile home may also make installing the top plate difficult. If there is not space for the 2x4 top plate to rest on the 3 1/2" side, it can be turned on edge or 2x2 material could be used for the top plate instead. If 2x2 material is used, make sure to pre-drill with an 1/8" bit before screwing into place.
  - If there is nothing to attach the top plate to on the short sides of a mobile home (or rim joist side of a house), the top plate can be installed behind and below the level of the rim joist (See Diagram 5)
- In some situations the J-Channel will need to be installed directly into the metal cross member or directly to rim joist.

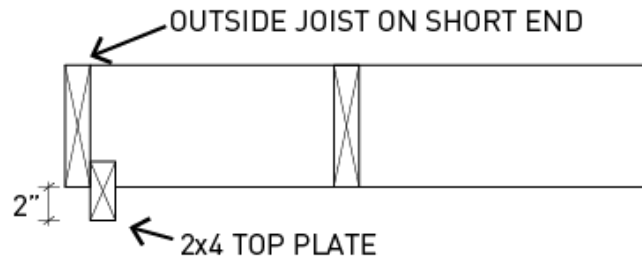



## Install Bottom Plate

- Cut 12" pieces of rebar that will be used to anchor the bottom plate into place
  - Use a circular saw or an angle grinder with a metal cutting blade
  - Wear leather gloves, ear and eye protection, and **DO NOT TOUCH** the pieces directly after cutting, they will be hot
- Drill ½" holes in base plates every 6' or at each end of pieces shorter than 6"
  - **When planning for rebar placement be cautious of any underground utilities and allow a 3' clearance from them with the rebar**
- Use a plumb bob from the outside surface of the top plate to determine where the bottom plate will rest (See Diagram 6)
  - When bottom plate is directly under the top plate, hold in place and pound in the pieces of rebar (heavier hammers will be better for this)

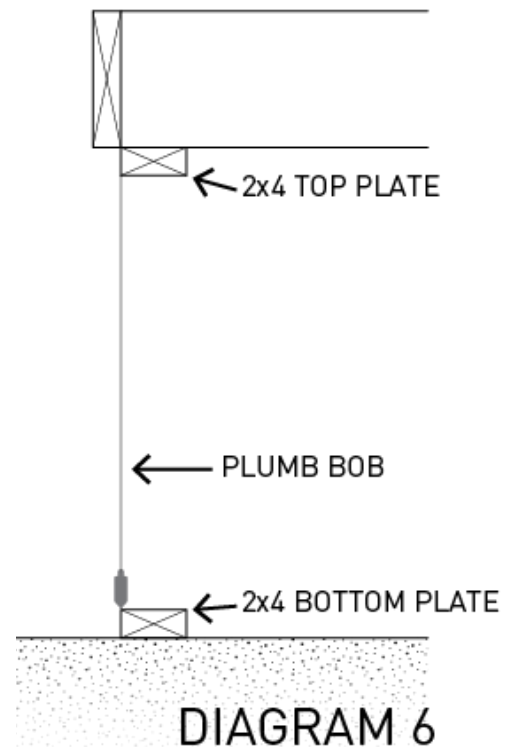

## Install Vertical Framing Members

- Vertical framing members will be 2x4 material
- Determine needed vertical framing members
  - If the space between the top and bottom plate is under 36" there should be vertical members every 4' (See Diagram 7A)
  - If the space is between 36" and 60" there should be vertical members every 4' and a center brace that runs mid-height inside the vertical members (See Diagram 7B)
  - If the space is over 60" there should be vertical members every 4' and two horizontal braces, evenly spaced and running perpendicular in between vertical members
- Mark location of the vertical members on the top plate
  - From the corner, the center of each vertical member will be at 4', 8', 12', 16', etc... (See Diagram 7)
- Read section on access doors on pages 229-230 and plan for those during vertical framing member installation

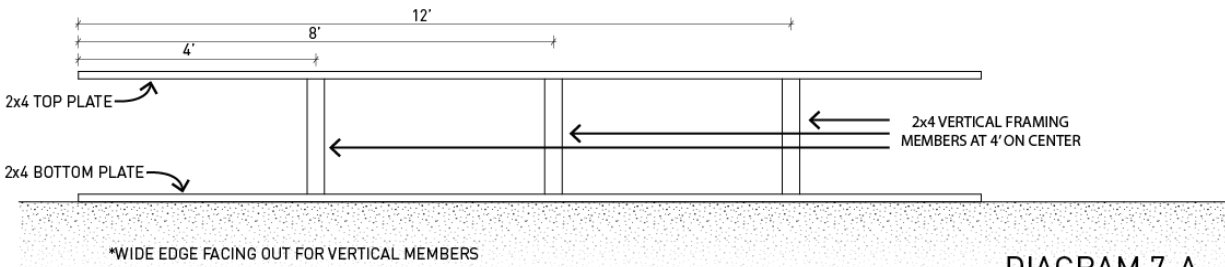

DIAGRAM 7-A

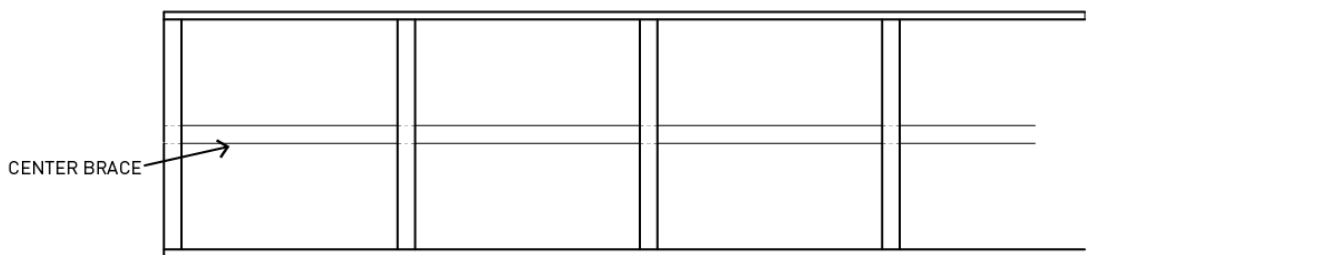

DIAGRAM 7-B

- Measure between the top and bottom plate to get the length for each vertical member
- Turn vertical members so that the wider side faces out (See Diagram 7)
- Fasten at the top plate and then use level to make sure member is plumb before fastening to bottom plate
  - Toe-screw members into place with 3" deck screws
  - Pre-drilling with a 1/8" bit can make toe-screwing easier
- At each corner, install vertical members 2 1/2" away from the true corner (See Diagram 8), corner piece dimensions may vary depending on distributor
  - Look ahead at corner pieces and Diagram 10

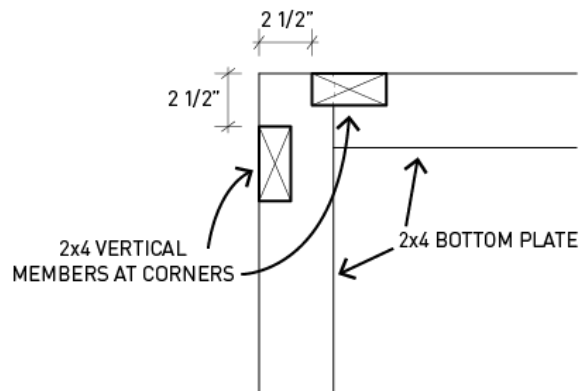

DIAGRAM 8

## Trench Around Bottom Plate

- After framing is complete, make a trench 4-6" inches into the dirt in front of the bottom plate (See Diagram 9)
  - Make sure the trench goes straight down from the bottom plate so that the vinyl will not bend when installed

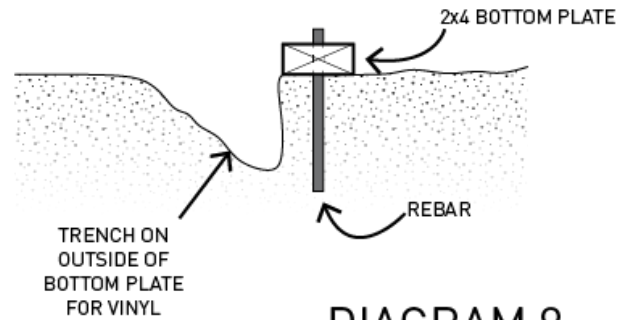

DIAGRAM 9

## Install Vinyl Trim

- Install vinyl corner pieces
  - These pieces will run from the top of the top plate to several inches into the trench, attach to the corner vertical members with roofing nails through the nailing tabs every 12"-18" (See Diagram 10)
- Install J-channel
  - J-channel will run only across the top plate, with the opening facing down (See Diagram 11)
  - Tuck the J-channel into the outside corner piece, then attach every 12-18" to the top plate with roofing nails (See Diagram 10)
    - Make sure to push up on J-channel when installing so that it does not sag
    - Start at one end of J-channel and work to the other to avoid sagging
  - If outriggers interfere, measure and cut pieces to rest between them

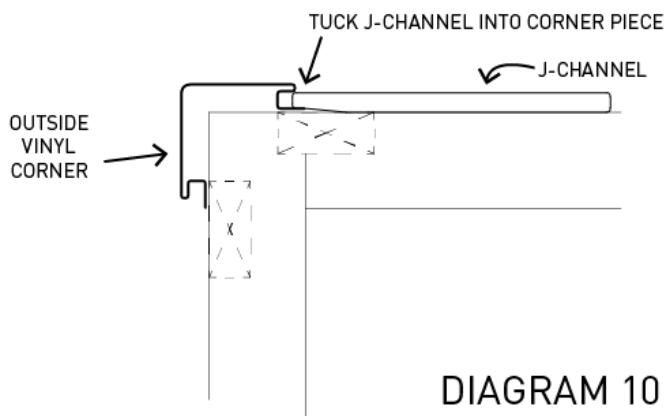

DIAGRAM 10

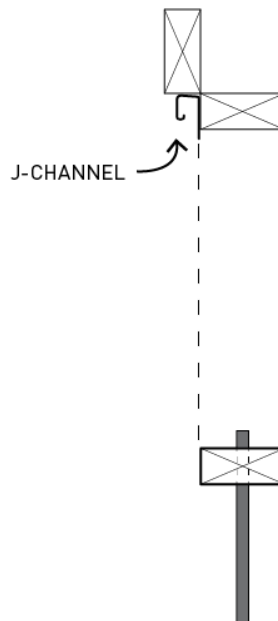

DIAGRAM 11

## Access Doors

Access doors should be located near water/utility shut offs and other places the homeowners may need to be able to get to

- The height of the door will depend on the height of the underpinning at that location, but should be 2 ½' - 3' wide
- Install vertical framing members to create opening for access doors
- Build a frame for door using 3" deck screws that will leave a slight gap all the way around when the door is in the opening (See Diagram 12)
  - Test fit before installing diagonal members
  - Install diagonal members in frame
  - To find angle, lay the wood across the frame and trace the needed angle
- Cover the door with either ½" plywood painted with exterior paint or trim with J-channel and use pieces of underpinning on door frame (See page 142-144 of vinyl siding section for instructions on installing J-channel around door)
- Attach door to frame using exterior hinges and make sure it swings conveniently
- Install latch and make sure that the door opens/closes well
- Install J-channel on either side of the opening for the access doors to catch the edges of the vinyl pieces (Shown in left side of Diagram 12)
  - Trim these vinyl pieces the same as pieces at the end of a row
  - Tack these partial pieces through the interlocking tab into the nailing flange of the previous piece using white aluminum trim nails

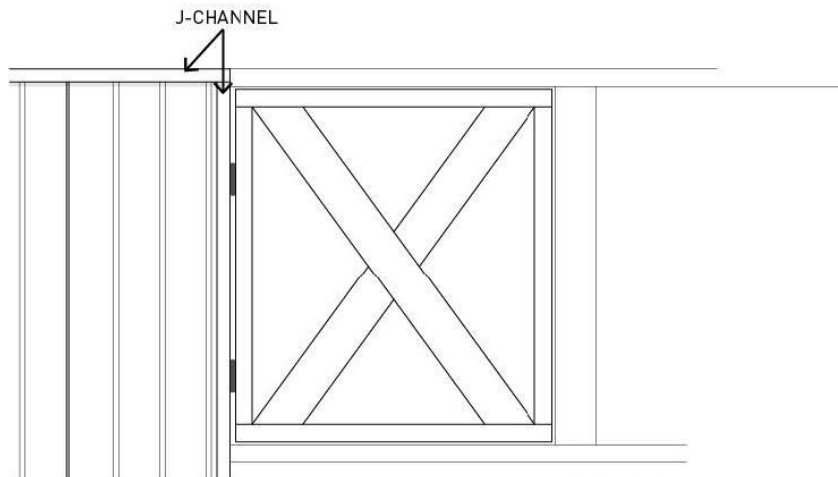

DIAGRAM 12

## Install Vinyl Pieces

- The underpinning pieces will be cut to length (from 12' pieces) and be installed vertically, interlocking with one another
- Soffit material can be used for underpinning, the majority of the material will be solid, some will be vented
  - **See below on venting before starting to install vinyl pieces**
- Measure from inside the top of the J-channel to about 3" below bottom of the base plate
  - Use framing square to make square marks
  - Use tin snips to cut vinyl pieces to length
  - **Measure each piece individually**
- Insert the non-tab side of the first piece of underpinning into the track of the corner piece, push up to the top of the J-channel (See Diagram 13 and 14)
- Attach at the top, check for plumb, then attach at the bottom with roofing nails
- After the first piece, each piece will lock together vertically
- Attach each piece at the top and bottom with roofing nails, and attach every fourth piece to the vertical members through nailing flange
- At the end of a side of the house, if the remaining piece to be installed is less than the full width of a normal piece, cut it lengthwise to the appropriate width
  - Make sure to measure from the non-tab side so the partial piece will still interlock
  - All partial pieces should terminate into a corner piece or J-channel
  - Tack these partial pieces through the interlocking tab into the nailing flange of the previous piece using white aluminum trim nails

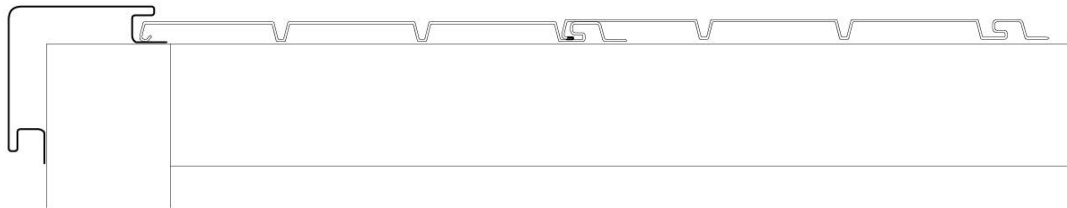

DIAGRAM 13

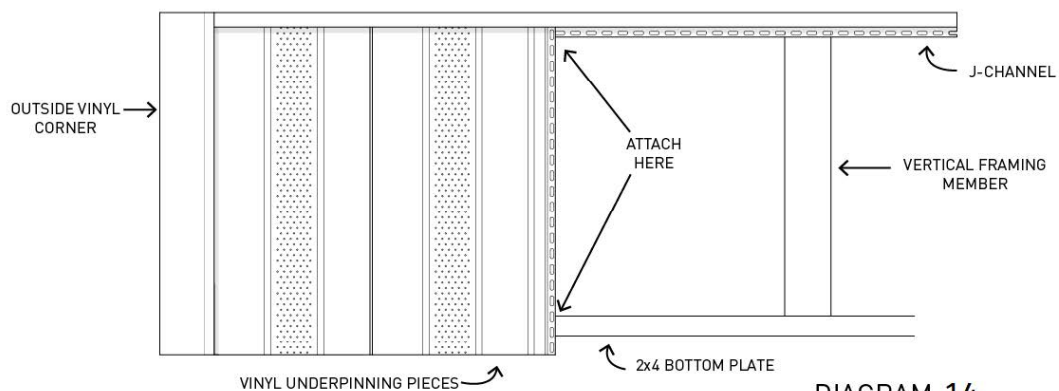

DIAGRAM 14

## Venting

- Vented pieces of underpinning must be installed at all corners and half way on long sides of the home
  - The vented vinyl pieces will interlock the same way as the non-vented, they will just be used in certain locations
  - At each highlighted section in Diagram 15, there should be 3 pieces of vented vinyl underpinning (3 pieces on each side of corner)

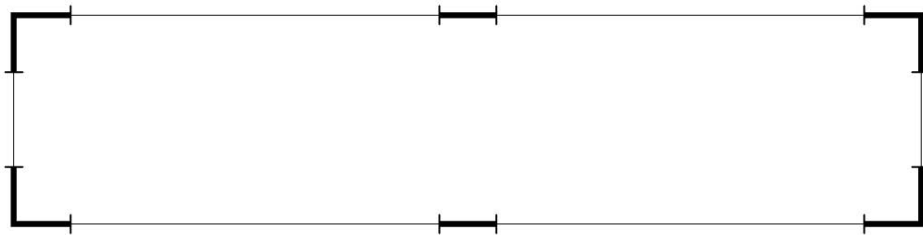

DIAGRAM 15

## After Vinyl Installation

- After vinyl pieces are installed, push the dirt back up against the bottom of the vinyl so that it slopes away from the house, creating positive drainage (See Diagram 16)

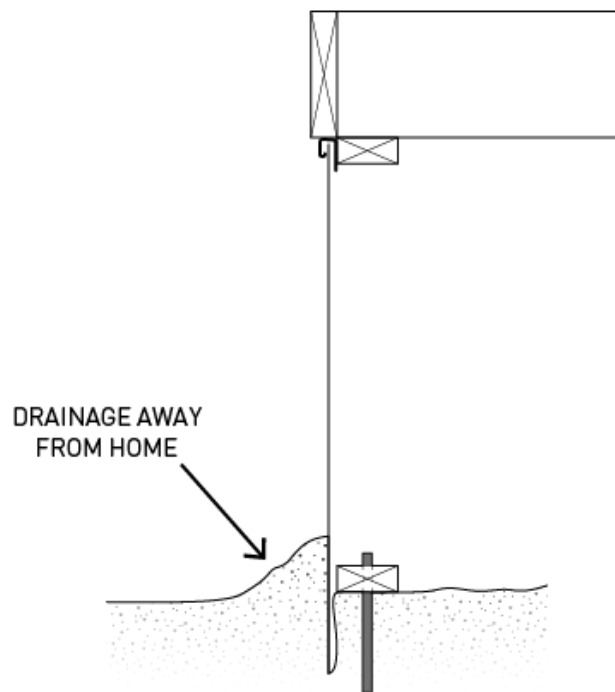
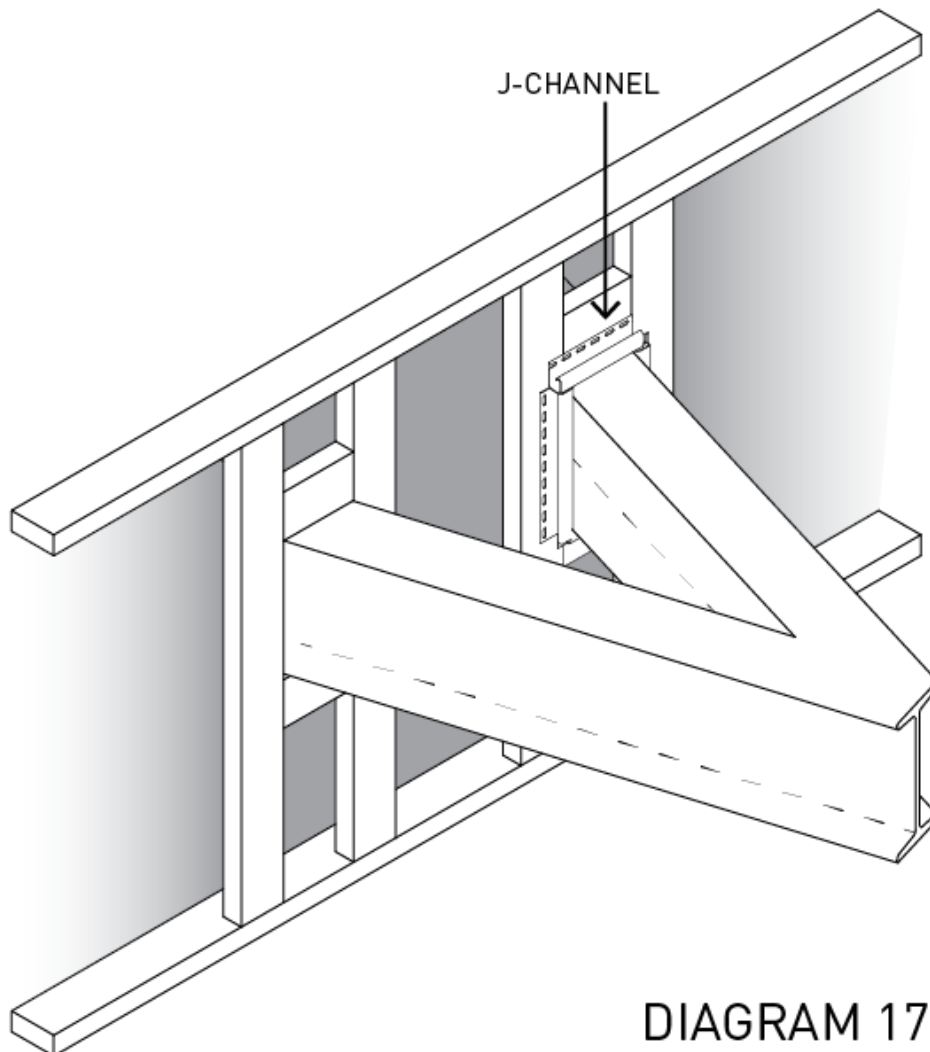

DIAGRAM 16

## **Mobile Home Hitches**

- Diagram 17 illustrates how to install framing for underpinning around hitches
- The right side of the hitch in Diagram 17 shows J-channel installed to the framing around the hitch
- Follow instructions for how to install the J-channel (explained in the vinyl siding section of the manual)
- Similarly to how the vinyl underpinning fits into the J-channel along the top plate, it should be measured and cut to fit into the track around the hitch
  - For more information reference the vinyl siding section on pages 151-154 and use the same principals



## **Crawl Space Venting Information**

Crawl space ventilation is important because it allows outside air to circulate within the crawl space. This is important because the outside air helps prevent moisture accumulation, which can cause rot to the floor system/foundation.

For every 150 SF of surface area of the crawl space, there should be at least 1 SF of venting.

*For example, if a single wide is 60' x 14', the crawl space area is 840 SF. (840/150 = 5.6)  
Therefore, there must be at minimum 5.6 SF of crawl space venting.*

If there is a home that has underpinning installed, but it is not vented there are several ways to add ventilation:

(Vents should be installed towards the top of the underpinning)

- For metal or vinyl underpinning, a grid of holes can be drilled (See above in Metal Underpinning)
  - 1/8" is the maximum size that the ventilation holes can be
- Holes can be cut and pre-made vents installed
  - For this method use sheet metal or neoprene screws
  - Make sure to silicone caulk around the hole for the vent before installing
    - Wipe off excess caulk after vent is installed
  - A typical vent for this would be 8"x16" and galvanized
    - These can be cut with tin snips to fit between the ribs in the tin if necessary
- For vinyl underpinning that is not vented, it may be possible to replace several pieces with vented vinyl pieces, but make sure you can match the width of the existing peices



## Underpinning Material List

| <u>Quantity</u>                       | <u>Item</u>  | <u>Purpose/Notes</u>   |
|---------------------------------------|--|--|
| <b>Framing:</b>                       |  |  |
| ___                                   | 2x4x___ PT<br>2x4x___  | bottom plate:<br>top plate:<br>(2x4 can come in any length) <i>Perimeter of home (in feet)/length of lumber = # of pieces</i><br><br>Vertical members for each corner, other vertical/horizontal members (as applicable), access door material   |
| ___                                   | 1/2" (#4) Rebar  | For anchoring bottom plate to the ground<br>1' of rebar is need for every 6' of base plate<br>→ <i>Perimeter (in feet)/6' = # of pieces of rebar needed</i><br>→ <i># rebar needed/10' (typical selling length of rebar) = # of 10 pieces</i><br>Add a few extra pieces of rebar   |
|                                       | 3" Screws  | Used to attach top plate and vertical framing  |
| <b><u>For Vinyl Underpinning:</u></b> |  |  |
| ___                                   | J-Channel  | Perimeter of home plus any needed for access door trim, hitches, etc., comes in 12' lengths  |
| ___                                   | Outside Vinyl Corners  | Come in 10' lengths  |
| ___                                   | Inside Vinyl Corners   | Come in 10' lengths  |
| ___                                   | Solid (non-vented) Soffit  | Used for the majority of the underpinning<br>Sheets are 1' wide and 12' long   |
| ___                                   | Vented Soffit  | Used for venting at specific locations<br>Sheets are 1' wide and 12' long<br>→ <i>Height x length = surface area</i><br>→ <i>Add all sides to find total surface area</i><br>→ <i>Total surface area x 1.1 = Added 10% for error</i><br>→ <i>(Total surface area + 10% error)/12 (SF in each piece) = # of pieces needed</i> |
|                                       | Roofing Nails  | Used to attach vinyl trim and underpinning sheets  |
|                                       | White Aluminum Trim Nails  | For attaching partial pieces at corners/access doors   |
| <b><u>Access Door Material:</u></b>   |  |  |
| ___                                   | 1/2" Plywood   | To cover the frame   |
| ___                                   | 1 1/2" Exterior Screws   | To fasten the plywood to door frame  |
| ___                                   | Exterior Primer/Paint  | To paint access door   |
|                                       | <i>Or get vinyl/J-channel or metal to cover access door with</i> |  |
| ___                                   | Exterior Hinges  |  |
| ___                                   | Latch for Access Door  |  |

## **Recommended Tools**

### **Safety:**

Gloves (Sturdy/leather for working with metal)

Glasses

Ear Plugs

### **Power Tools:**

Miter Saw

Drills/Impact Drivers

→ T-25 Driver to match deck screws

→ 1/8" Drill Bits - to pre-drill for metal sheets/venting (they dull quickly so 4-5 would be useful)

→ 1/2" Wood Drill Bit to pre-drill for rebar pieces

→ 1/2" Metal Drill Bit for pilot holes for jigsaw cut outs (metal only)

Circular Saw

→ Metal Blade to cut rebar

(or) Angle Grinder - with metal cutting blade to cut rebar

Jig-Saw

→ Metal blade to notch around hitch/other obstacles (metal only)

### **Digging Tools:**

Pick Axe - to dig trench around bottom plate

Shovel - to level out ground as needed and create positive drainage

### **General:**

Basic Hand Tools (Tape measures, hammers, pencils, speed square, etc)

Saw Horses

Extension Cords/Splitters

Caulk Gun

Tin Snips

Level

Heavy Hammer - to pound in rebar

Plumb Bob

Framing Square







# Porches

**Why Porches?** For safety, stairs and porches must have handrails and must be sturdy. Homes should have two exits available for use in case of emergencies. Additionally, porches can provide outdoor living space and are favorite parts of the home for many homeowners.

## Safety

- Wear gloves when removing debris/old structures
- Make sure to bend down or remove and nails sticking out of any debris lumber
- Wear safety glasses when cutting or working near someone cutting with power saw
- Communicate with homeowner/block off entrance if needed
- Put up temporary rails overnight if needed for homeowner to have accessibility to home
- Set up a cutting station facing away from the work area with plenty of space to maneuver

## Porch Project Planning

- While you are working on the porch, does the family have another way in and out of the house?
- Are there any underground utilities - water/electric in the area where the porch will go?
- Where will the stairs come off the porch?
  - This should be convenient to the way the door swings if possible
- Will any permits/inspections be needed?
- What size will the porch be? ASP builds a standard 5'x5' or 6'x10'
- All porch material will be pressure treated lumber

## Measurements Needed

- **Measure the height from the bottom of the door from the ground** - determines the length of posts and stringer length
- Determine which posts to use
  - If porch will be under 8' high use 4x4 posts
  - If porch will be over 8' high use 6x6 posts (porches of this height must be approved by construction consultant or Home Repair Coordinator)

## Quality Control

### **Posts/Frame**

- Make sure a hole is dug for the post that will be used for the top of the stair handrails
- Make sure posts at top of stairs are 36" wide from inside to inside of the posts
- Make sure framing is dropped 1 ¼" below bottom of door frame to allow space for deck boards
- Make sure joists are parallel to the house so that the deck boards will be perpendicular
- Make sure additional framing member is installed against the outside of the 2 posts closest to the house - attached to the posts with ledger loks
- Make sure frame is attached to posts with ledger loks
- If porch is over 30" tall make sure diagonal bracing is installed

### **Decking**

- Make sure decking does not interfere with door opening
- Make sure deck boards are crowned
- Add blocks below where notches are made in deck boards around posts

### **Steps**

- Make sure first step is down, not a step out
- Make sure rise/run is consistent
- Make sure stringers are square to the porch

### **Handrails**

- Make sure bottom and top rail are flush to the inside of the posts around the porch
- Make sure finished handrail height is 36"
- Make sure spacing of pickets is 3 ½"
  - Make sure to pre-drill holes for pickets

## Common Mistakes

### **Posts/Frame**

- Hole is forgotten until frame is set, difficult to dig around frame
- Posts set 36" outside to outside and stairs end up too narrow
- Framing butted up to the bottom of the door frame, no space for deck boards
- This framing member is forgotten and there are only deck screws holding the back of the frame to the posts
- Diagonal bracing forgotten altogether

### **Decking**

- Adequate space not left for deck boards
- Blocking forgotten and boards weak around posts

### **Steps**

- Ledger board is forgotten and stairs are attached to frame making the first step out, not down

### **Handrails**

- Bumpers are attached to the inside of the posts, not between the posts
- Posts cut off at 36", making finished handrail height too high
  - Pre-drill step skipped, pickets splitting
- Pickets installed upside down

## After Work is Complete Quality Control Check

- Make sure that all deck boards that were notched for posts are supported underneath
- Make sure finished handrail height is 36"
- Make sure the first step is down, not out and that the steps are 36" wide
- Make sure that the tops of the pickets and posts are covered by the 2x4 cap board at top of the handrail

## Group Leader Tips

- Some volunteers can split cap blocks while others are digging
- Once the exterior frame is put together
  - Some people can start pre-cutting deck boards to length while others install common joists
  - Some can start working on stairs (laying out and cutting stringers) while joists/decking are installed
    - The stair assembly can be largely put together separate from the porch
    - Once one stringer is cut out - you can use it to mark where the holes for the posts at the bottom of the stairs will go and start digging those
    - Once the stair assembly is put together, someone can pre-cut the treads for the stairs
- Posts can be cut to height and top and bottom rails installed after the frame is put together - **just make sure to account for the 1" of the decking if it is not installed yet**
- Pickets can be pre-drilled in bulk somewhere to the side - just make a sample so that the screws will be sure to hit the rails

# Porch Instructions

Two standard sized porches are 5'x5' and 6'x10'

## Build Frame

- Build 5'x5' frame (See Diagram 1A)
  - From 2x6 cut two pieces 57" and two pieces 60"
  - Arrange these to form the outside perimeter of the frame at a finished 60"x60" (5'x5')

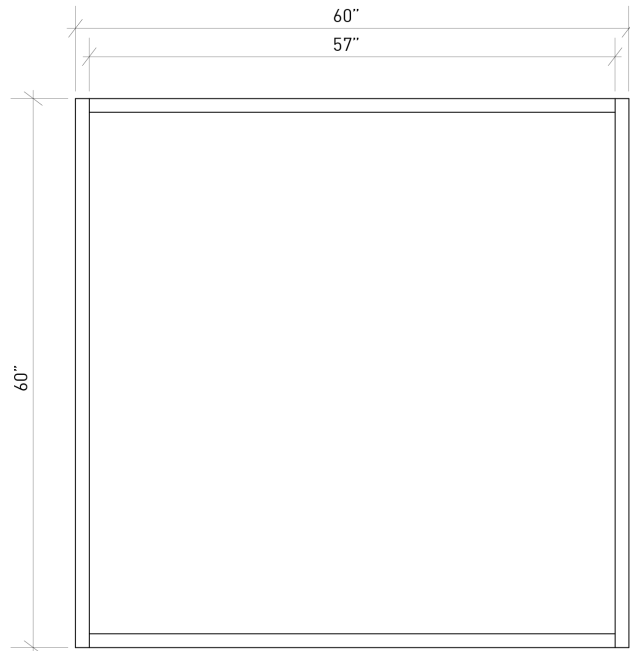

DIAGRAM 1-A

- Build 6'x10' frame (See Diagram 1B)
  - From 2x6 cut two pieces 72" and two pieces 117"
  - Arrange these to form the outside perimeter of the frame at a finished 72"x117" (6'x10')

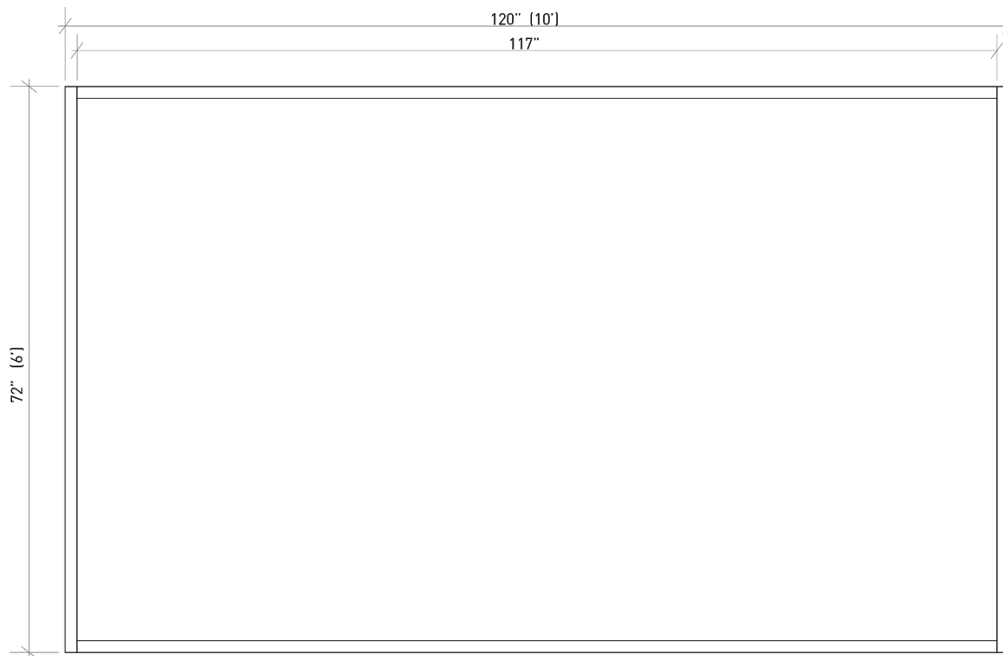

DIAGRAM 1-B



- Use a framing square to make sure the corners are square and add some temporary diagonal bracing to keep the shape while the frame is moved
  - Arrange bracing so that it will not be in the way when it is held in place against the house and does not interfere with corner posts.
- Move frame to desired location for porch
  - Pay attention to which direction the door swings when placing frame so that homeowners will not be walking into porch rail

### Install Posts and Frame

For 5'x5' (See Diagram 2A)

- Mark each corner on the ground, holes will be dug for posts at these marks (See Diagram 2A)
- There will be a 5th hole for the post at the top of the stairs
  - Measure over 42" from the corner that the stairs will be on to indicate where that hole will be
  - Stairs can come off front or either side
  - **IF BUILDING FOR A RAMP BE SURE TO SPACE POSTS 41 1/4" APART.**

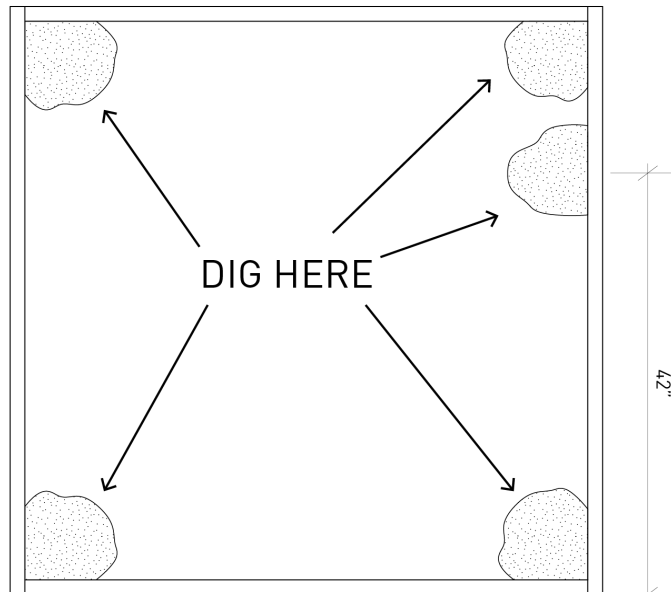
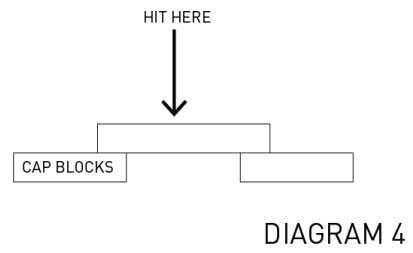
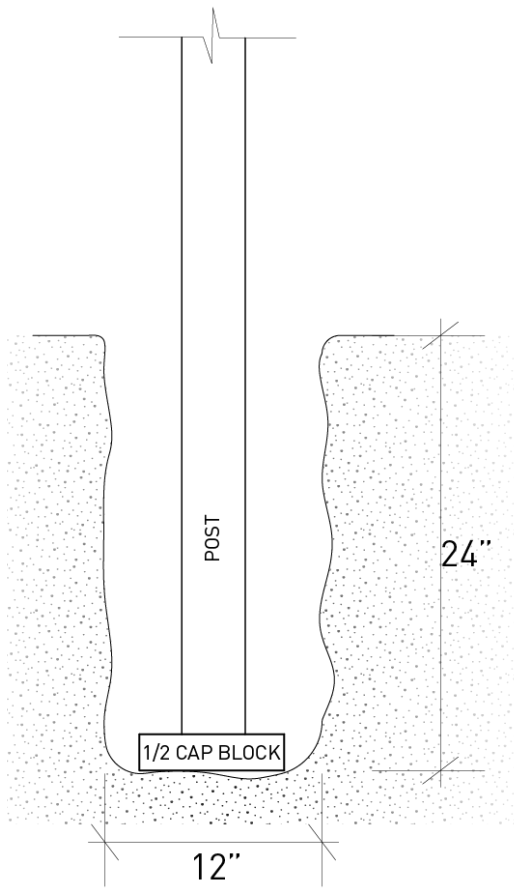
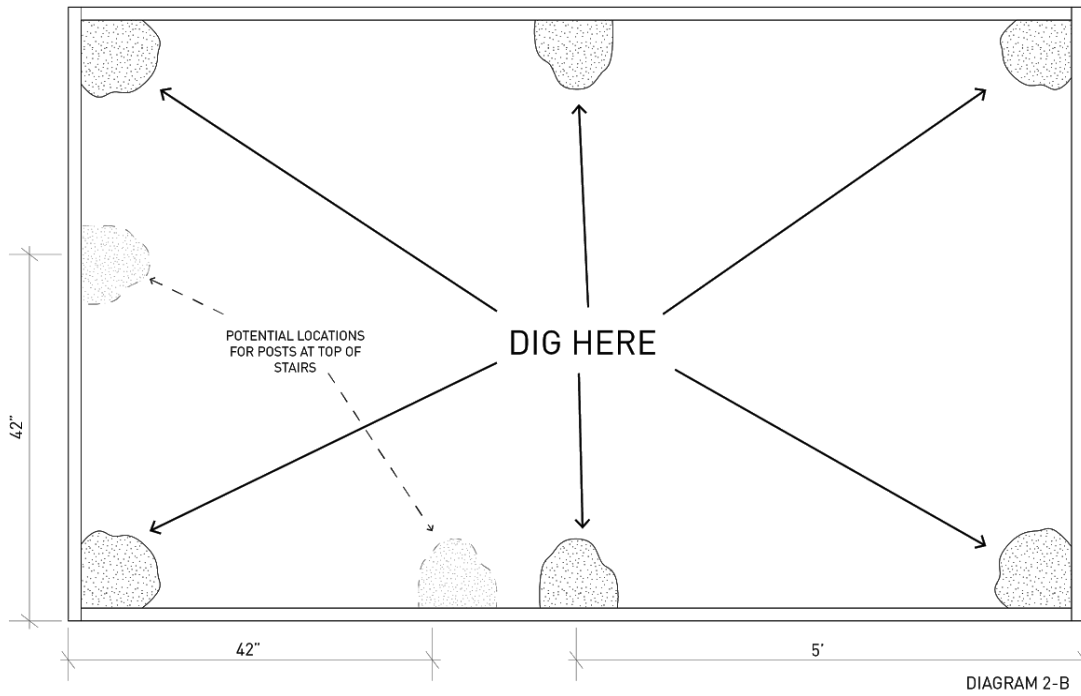

DIAGRAM 2-A

For 6'x10' (See Diagram 2B)

- Mark each corner on the ground and in the middle of the 10' sides, holes will be dug for posts at these marks
- There will be a 7th hole for the post at the top of the stairs
  - Measure over about 42" from the corner that the stairs will be on to indicate where this hole will be
  - Stairs can come off of front at each corner or either side
- Dig holes 12"x12"x24" (or 16"x16"x24" for 6x6 posts) (See Diagram 3)
- Tamp/pack dirt flat in bottom of hole with digging bar or sledge
- Place either a split cap block or 3" of dry sackrete in the bottom of each hole
  - For cap blocks, split with digging bar or sledgehammer, place half of a cap block in each hole, and make block level (See Diagram 4)
    - Do not split all of the blocks - 2 will be needed whole for base of stairs
  - For sackrete, after pouring in 3", tamp down and make flat with sledge or digging bar



- Leaving the frame over holes, set the two (for 5'x5') or three (for 6'x10') posts in the holes touching the home and lift frame into place
  - Use a deck board as a spacer and leave a ¼"- ½" gap between the door sill and the top of the decking
  - Make sure posts are plumb and the frame is level between the two posts (don't worry about level of frame perpendicular to the house right now)
  - Temporarily fasten with screws
  - Use a temporary support for the front of the frame (a 2x4 touching the ground and fastened to the frame works well, or two pieces for a 6'x10') (See Diagram 5)
  - Back fill holes and compact dirt several times in the process

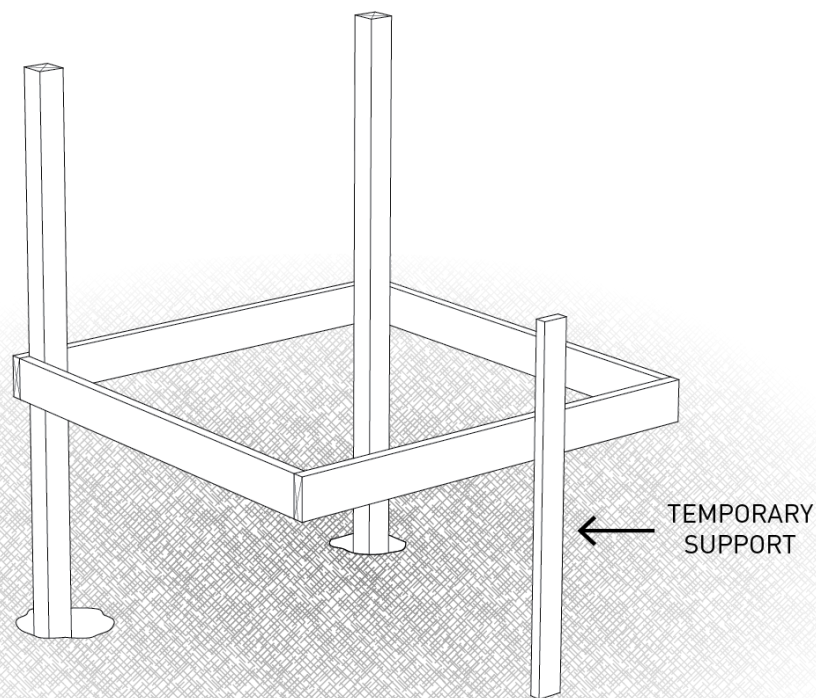

DIAGRAM 5

- Set the additional posts (3 more for 5'x5' and 5 more for 6'x10')
  - Make sure they are plumb, temporarily attach with screws
  - Backfill holes and compact dirt (\*see next page if notching 6x6s)
- Do not cut off posts - they will be used for handrails
  - For 6'x10' only, cut off the one post in the center of the long side against the house even with the top of the frame (See Diagram 7B)
- An additional 2x6 frame member should be installed in front of the rear posts for both 5'x5' and 6'x10' (See Diagram 6)
- Fasten frame to posts with 2 ledger loks where each frame member intersects a post after double checking plumb/square

## Special Consideration for using notched 6x6's

If working in a county that requires the frame of the deck to be supported by a notch in the 6x6 you can follow directions listed prior with some special considerations.

- It tends to be easier and look nicer to make the stairs the same width as the deck when using 6x6 posts. It takes away the need for the 5th post for the stairs on the deck, but requires a fourth stair stringer.
- If working in loose soil, a level 4" concrete pad may be needed instead of capblocks to ensure height of post remains consistent throughout process.
- When using the frame to mark and dig holes, remember the post will shift 1 1/2" after the notch is made.
- When leveling the frame additional braces may be required to hold the four posts plumb
- Once frame is level and temporarily screwed into posts, mark the top and bottom of the frame at the posts. These marks are where the notches will be located. (Mark specific post location on each post)
- Remove frame and posts. Move posts to a proper cut station and notch posts. Notching can be achieved by setting the depth of a circular saw at 1 1/2" and making several passes. The chips left can be knocked away with a hammer and cleaned up with a reciprocating saw.
- This will create a notch for both frame (band and rim joist) to fit into and be supported by. Attach using county approved fasteners. (ledger loks are accepted in most counties)

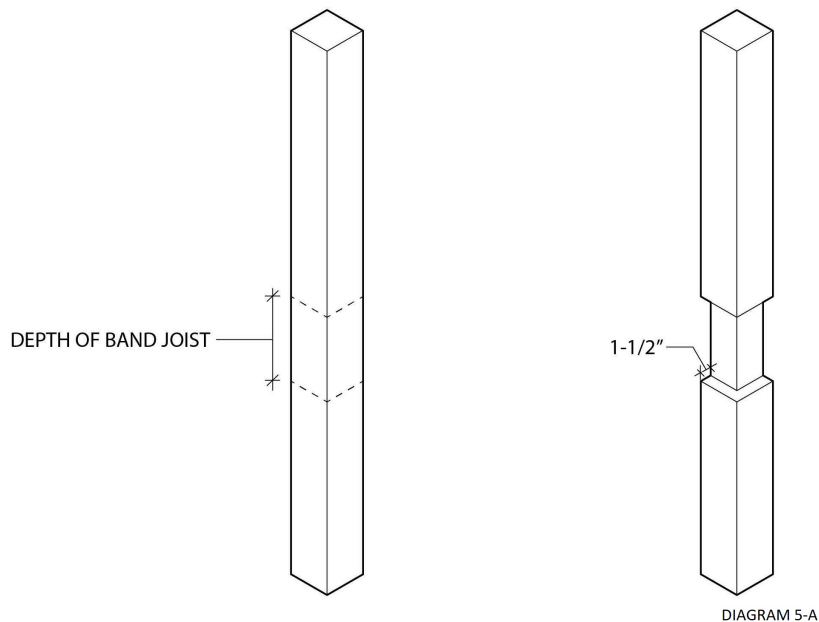

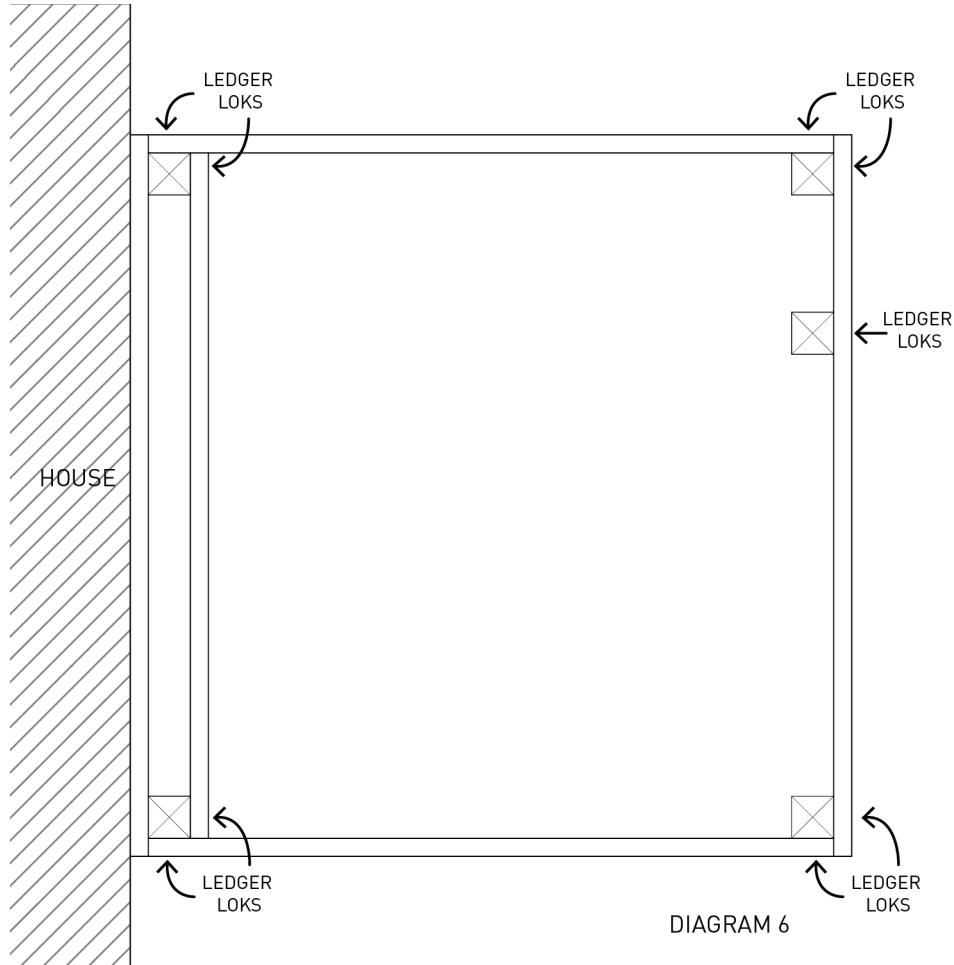

- Install common joists (See Diagram 7)
  - Joists should run parallel to the home
  - Install common joists every 16" on center
  - Measure and install each common joist with deck screws through the band joist
  - Once each joist is in place, add a 2x6 joist hanger using joist hanger nails in holes on the flat surface and 2 1/2" deck screws through the diagonal holes
- For 6'x10' only, install 2x6 ledger boards on both sides of the center posts running underneath the common joists (See Diagram 7B and 8)
  - Attach the ledger boards to the posts with ledger loks

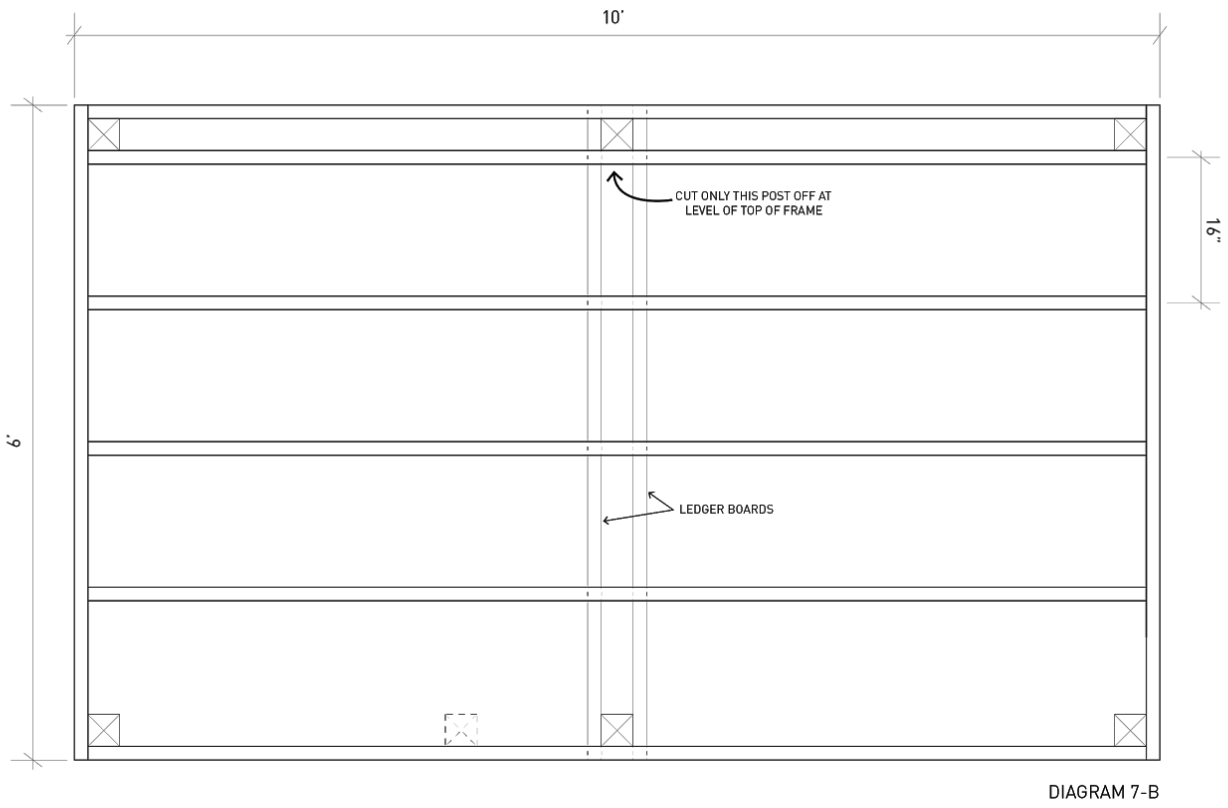
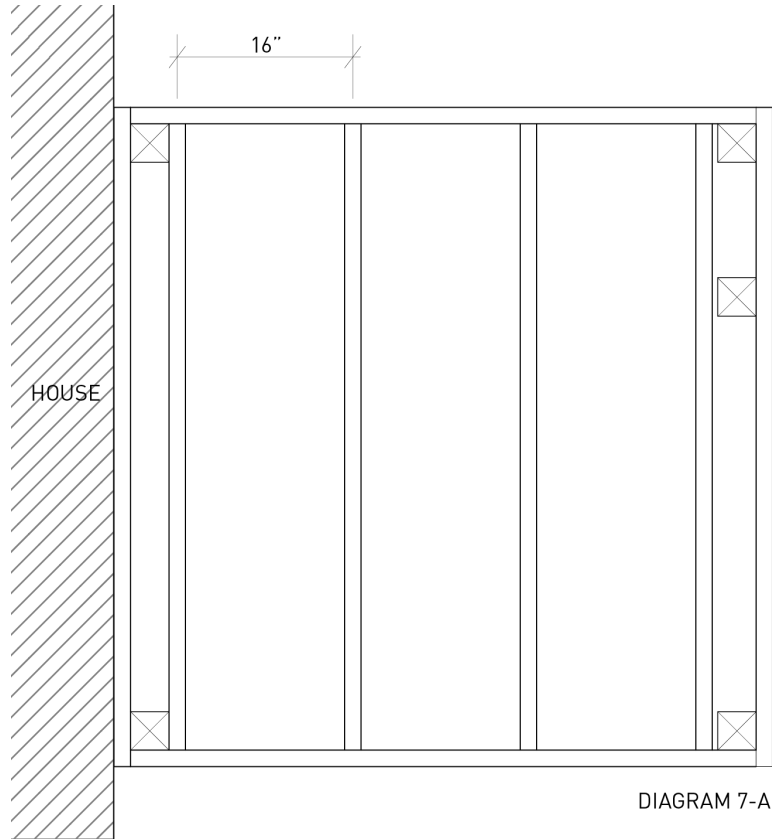

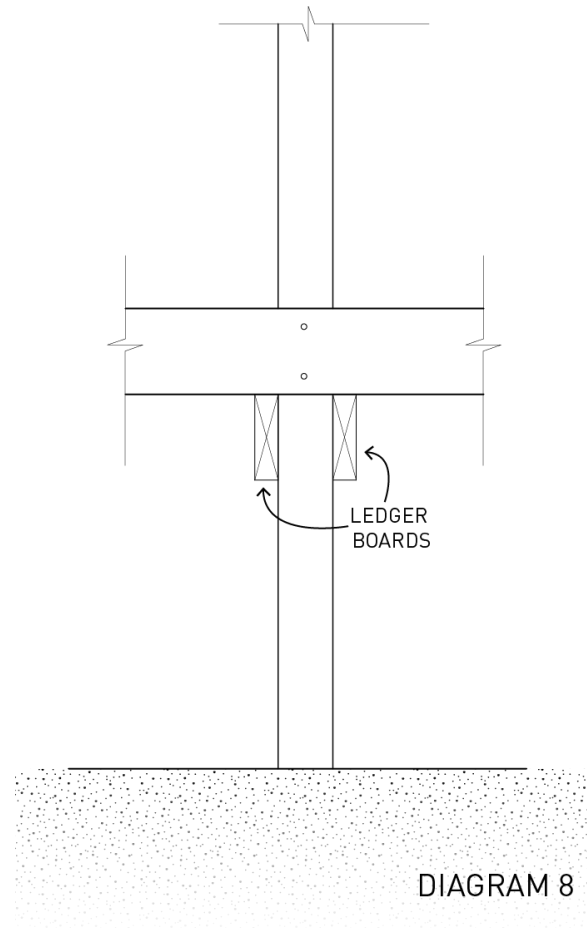

### **Install Decking**

- Add blocks (cut from 2x4) at each post to provide a bearing surface for boards where they are notched around posts (See Diagram 9)
  - Make sure to pre-drill the holes in these small pieces with  $\frac{1}{8}$ " drill bits to prevent them from splitting
- Decking will run perpendicular to the joists
- Allow for a 1" overhang of the decking over the porch frame
- Crown boards when installing by looking at the end grain of the boards (this helps water to run off rather than staying in place on the wood) (See Diagram 10)
- Notch around posts using a jig saw, do not put screws into short sides of the notches (they will break easily) (See Diagram 11)
- Put two screws through the deck board into each joist about 1" in from the edge of the board (See Diagram 11)
- Do not leave any spaces between the boards, as the treated lumber dries out it will shrink and small gaps will form to allow water to run between

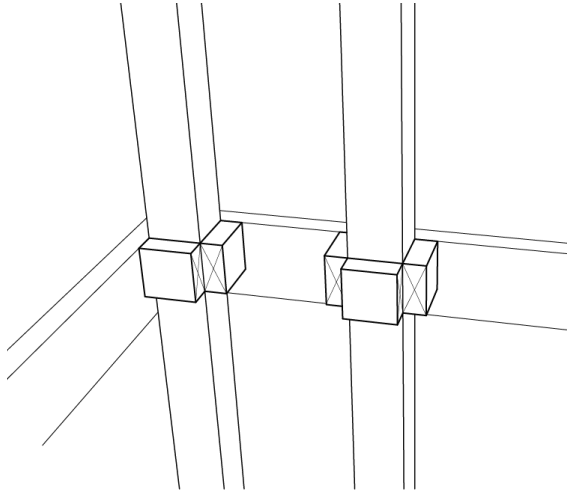

DIAGRAM 9

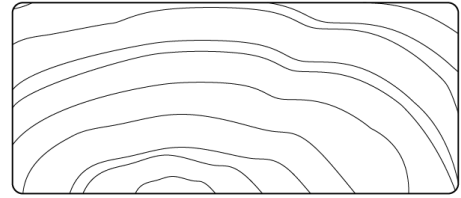

DIAGRAM 10

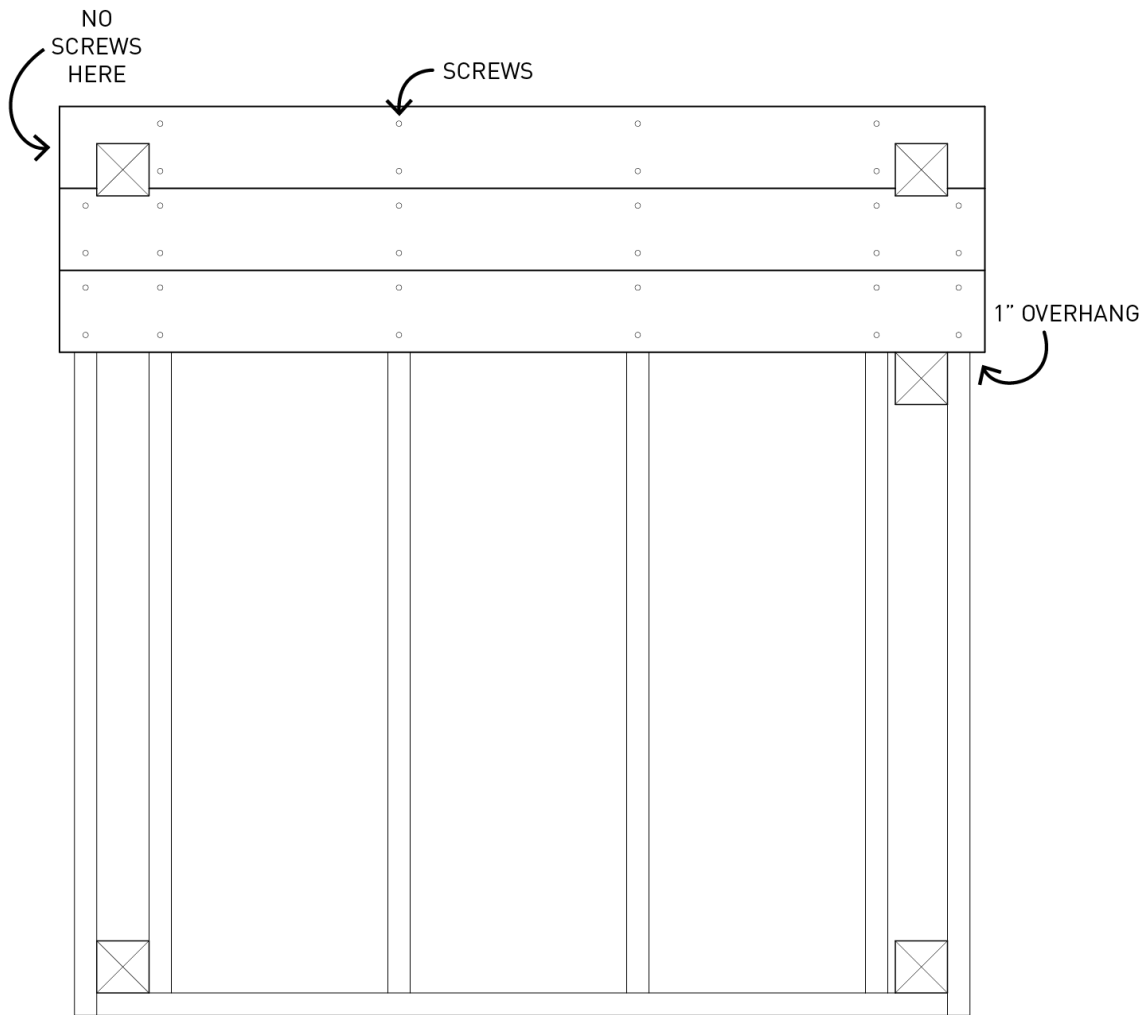

DIAGRAM 11



## Diagonal Bracing

- Diagonal bracing is required for all porches that are 30" or higher (from ground to walking surface) to increase stability of the porch
- Each corner porch post (except the one for the top of the stairs) should have 2 diagonal braces attached to it
  - For 6'x10' porches higher than 4' off the ground, diagonal bracing should be added to the middle posts on the long sides
- Braces should be cut from 2x4 with 45° cuts on each end
  - Bottom of the brace will attach to the post 2' below the framing of the deck (See Diagram 12)
  - Bracing should attach flush with the outside of the post and behind the frame of the porch (See Diagram 13)
  - Pre-drill holes with 1/8" drill bit and attach with 3" deck screws through diagonal brace into post/frame

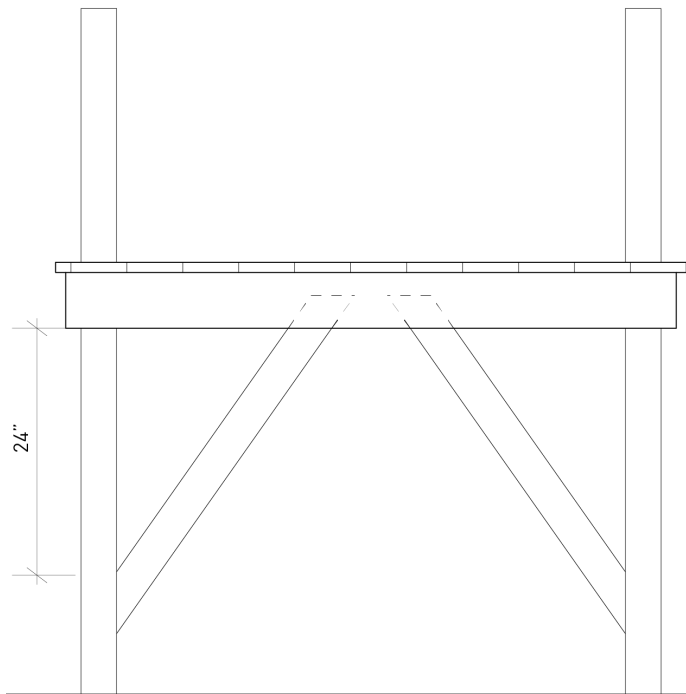

DIAGRAM 12

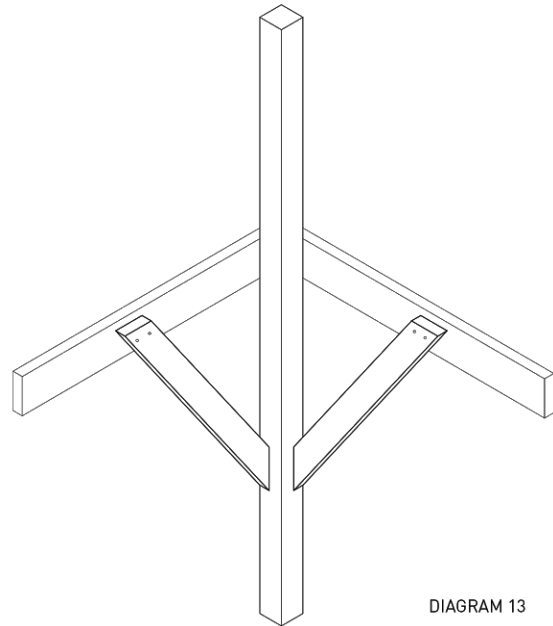

DIAGRAM 13

## Stairs

- Cut stair stringers from 2x12 material
- There will be three identical stringers
- The rise of the steps should be 6"-7 ½" and the run/tread should be 10"-11" (10 ½" is recommended)
  - **Determine the rise** by dividing the overall height of the stairs by the number of stairs to be constructed (roughly 7" per step) – you can use an online stair calculator if needed
  - Consider a lower rise (around 6" if building for elderly homeowners or homeowners with mobility issues)
- If the ground is sloping take that into consideration when determining number of steps

*For example:*

*If the top of the porch surface is 31" off of the ground, divide that height by a potential rise height until you get close to a whole number.  $31/7 = 4.43$ .  $31/6 = 5.17$ .  $31/6\frac{1}{4} = 4.96$ . 4.96 will round up to 5. Therefore, there will be 5 "risers" of 6 ¼". From the surface of the porch, the first step will be down (not out) and this will count as one of the five rises. Therefore the stringer piece that is cut out will only have 4 rises. There will also be 4 treads (number of threads and rises always matches).*

*The completed stringer will look like this:*

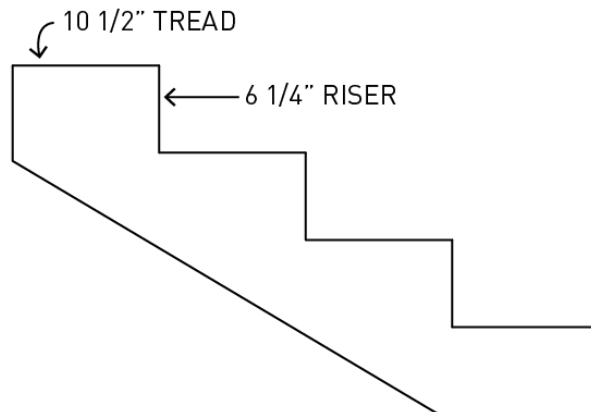

EXAMPLE DIAGRAM

- Once the rise and run are determined - lay out the stringer

In Diagram 14, 7" rise and 10 1/2" treads are used as an example to create a stringer with four rises of 7", the four rises includes the top step from the top of the stringer to porch surface (each porch will require a different stringer size)

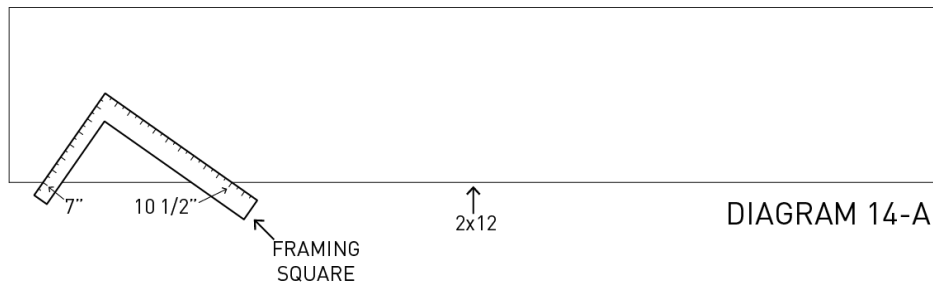

- Hold framing square on edge of 2x12 at riser and tread height and trace the outside of the framing square (See Diagram 14A)

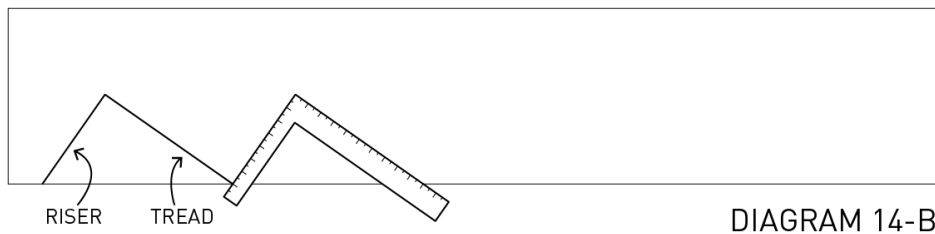

- Continue tracing this profile until there are the appropriate number of risers and treads (See Diagram 14B)



- Continue these lines at a 90 degree angle at the back of the top stair and the bottom of the the first stair. (See Diagram 14C)

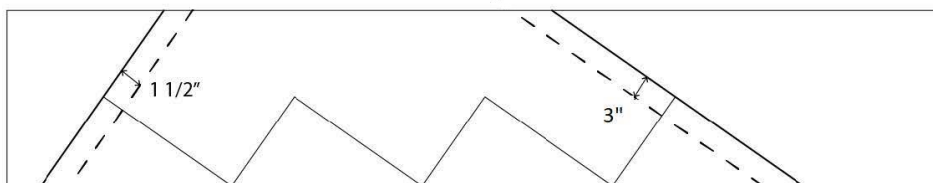

- Draw a parallel line that is 1 1/2" to the inside of the line at the back of the top stair and a line 3" from the line on the bottom of first stair. (See Diagram 14D)

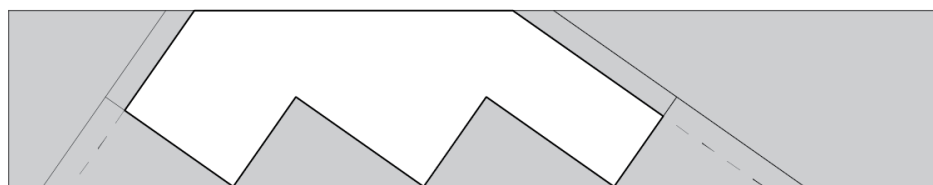

- Cut out stringer along darkened line, as in Diagram 14E
  - Make initial cuts on stringers with circular saw, do not cut past corner of where the right triangle shapes are being cut out or the stringer will be weakened
  - Finish corner of cut with hand saw or jigsaw
- Once one stringer is cut out, use that as a template and trace it for the two remaining stringers
- Assemble stair frame
  - Cut two pieces of 2x10 at 36" and one piece of 2x4 at 36"
  - The base of the stairs will sit on top of a 2x10 and 2x4 cross piece
  - A 2x10 cross piece will go across the back of the stringers (See Diagram 15 and 16)
  - The middle stringer should be in the center of both the top and bottom cross pieces
  - Fasten these pieces together making sure that they are square (See Diagram 16)

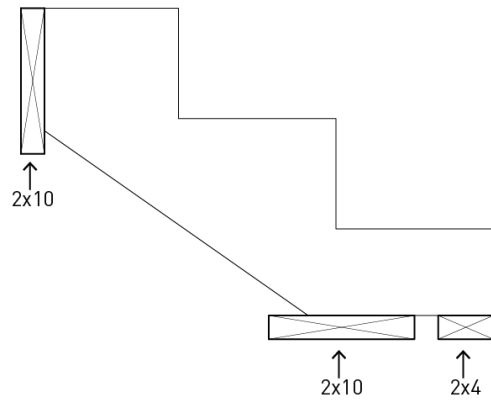

DIAGRAM 15

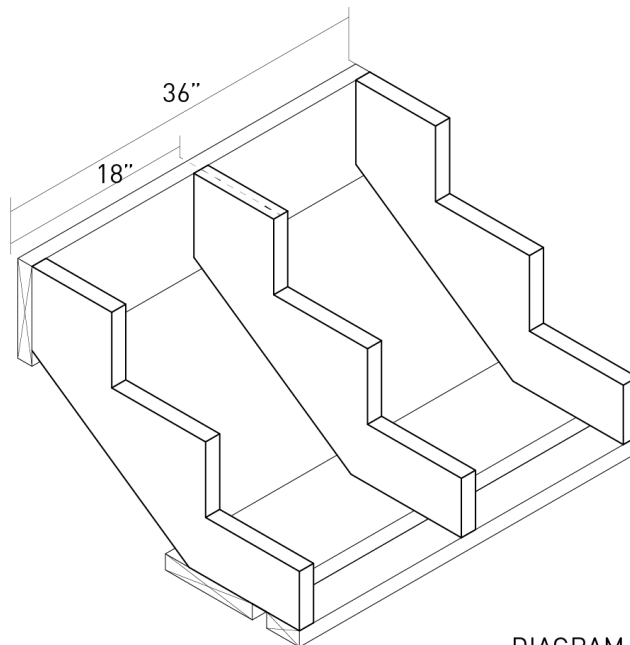

DIAGRAM 16

- Install Stairs
  - Across the two posts that act as the opening for the stairs, install a 2x10 that is cut to 43" using ledger loks (See Diagram 17)
  - Measure down from the surface of the porch the height of the riser plus 1 1/2"
    - For example, if the riser height is 6 1/4" (+ 1 1/2"), measure down 7 3/4"
  - Transfer that line across the ledger board that was just installed using a level, this is where the top of the stair assembly will go (See Diagram 17)
    - **This first step will be down, not out**

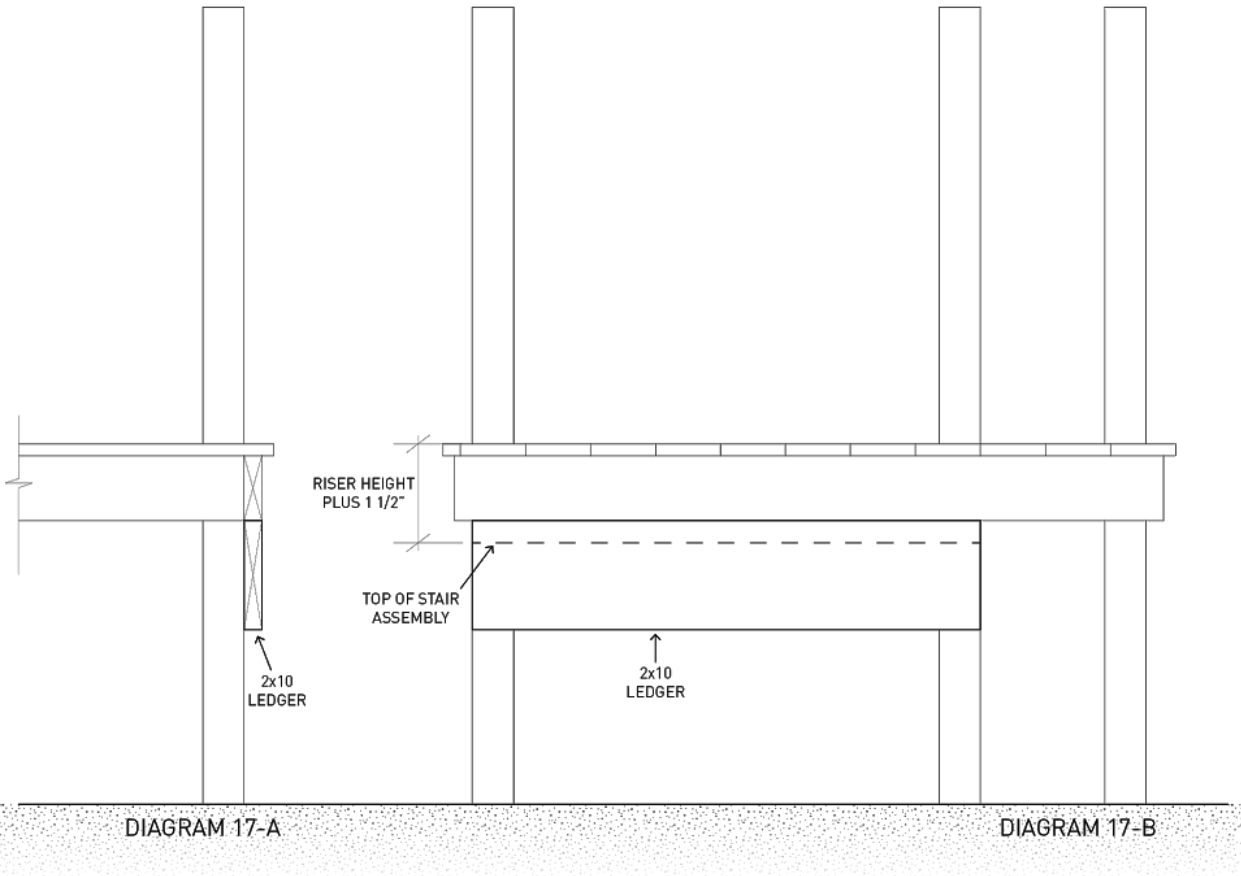

DIAGRAM 17-A

DIAGRAM 17-B

- Hold the stair assembly in place, dig out ground at base of steps if necessary to make sure treads are level
- While stairs are held in place, mark the far corners of the bottom step to indicate where holes will be dug for the handrails
- Dig holes for handrail posts 12"x12"x24" and place either a 1/2 cap block or 3" of sackrete in the bottom
- Dig out a rectangular hole for a full cap block so that the bottom of the stairs rest on the flat surface of the cap block, make the two blocks level (these may have to be adjusted slightly by sitting the steps on them and making sure everything is level and the steps are in contact with both blocks) (See Diagram 18)

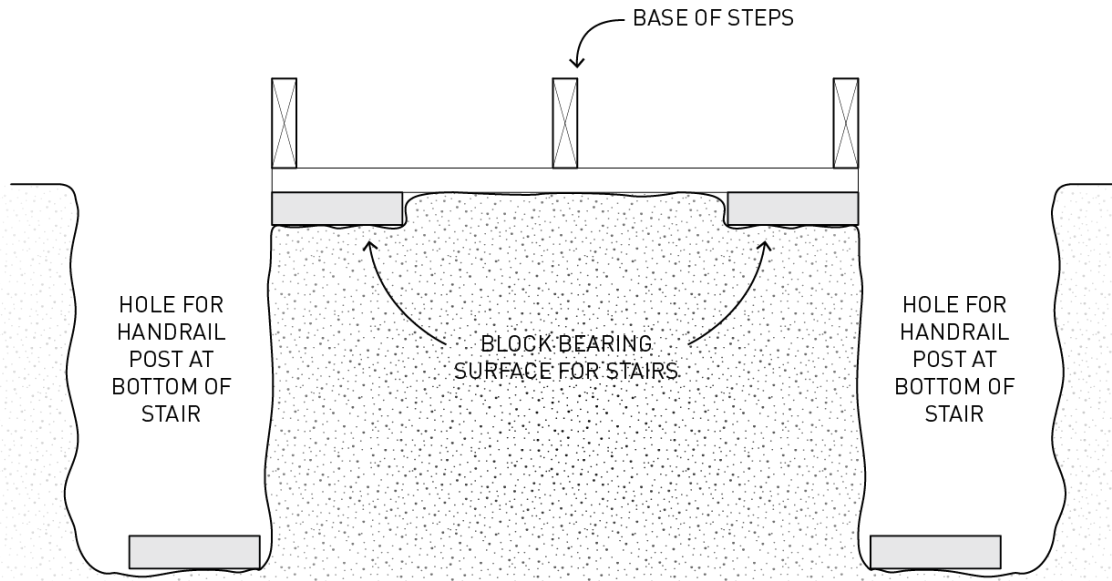
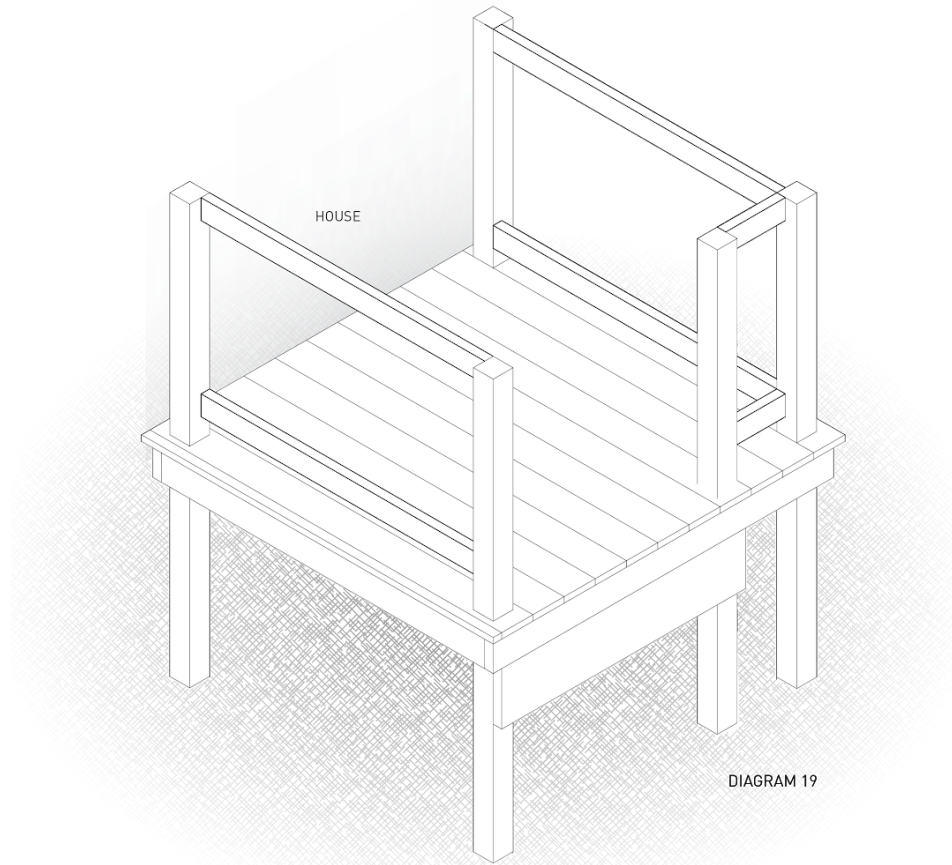

DIAGRAM 18

- Once the stair assembly is in place, fasten the stairs to the 2x10 ledger using 6 ledger loks
- After stairs are attached, set posts at the bottom of the steps
  - Make sure posts are plumb in both directions and attach to bottom of stringers using 2 ledger loks
  - Fill holes and tamp dirt
- Install decking on the stairs
  - **Use either 2x6 or 2x12 as stair tread**
  - Allow for a 1" overhang on each side

### **Handrails Around Porch Landing** (Stair handrail instructions below)

- Cut the posts in the frame at 34 ½" above surface of decking boards using circular saw at maximum depth from each side (finishing with reciprocating saw if necessary because of placement)
- Install bumpers/rails around frame
  - Top bumper will run flush with the tops and insides of the posts (See Diagram 19)
  - Bottom bumper will run flush with the inside of the posts and rest 3 ½" above the decking (sit on a 2x4 block while installing to get the right height) (See Diagram 19)
  - Measure each of these individually, make sure that they are snug
  - Pre-drill with ⅛" drill bit before toe-screwing the top and bottom rail into place (this will keep the wood from splintering)



- Use 2x4 as a cap that will sit flat on top of the top bumper and cover the tops of the 4x4 posts
  - Cut 45 degree angles where 2x4 caps come together at a corner
- Install pickets every 3 ½" with flat end at the top (2x4 width can be used at top and bottom as a spacing block) (See Diagram 20)
  - Cut pickets to length (measure from bottom of bottom rail to top of top rail)
  - Pre-drill holes in pickets with ⅛" drill bits, and install with 2 ½" screws
  - Start in the middle of each section between posts and work to either side, making sure the center picket that is installed first is plumb

SIDE VIEW

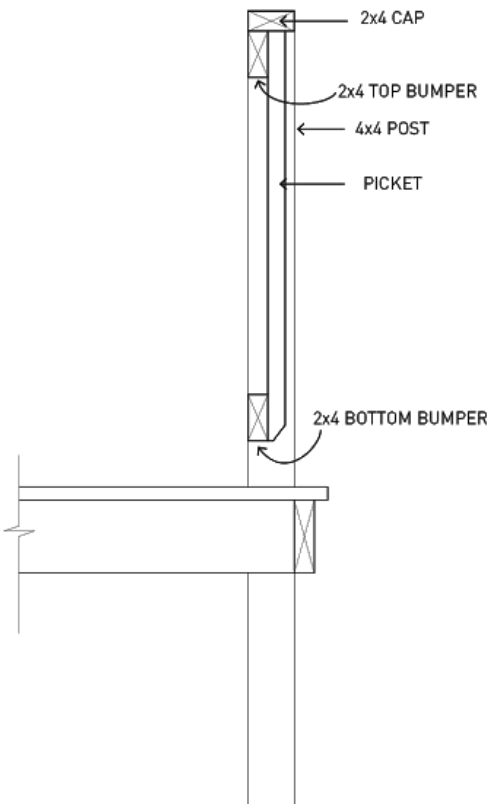

DIAGRAM 20-A

FRONT VIEW

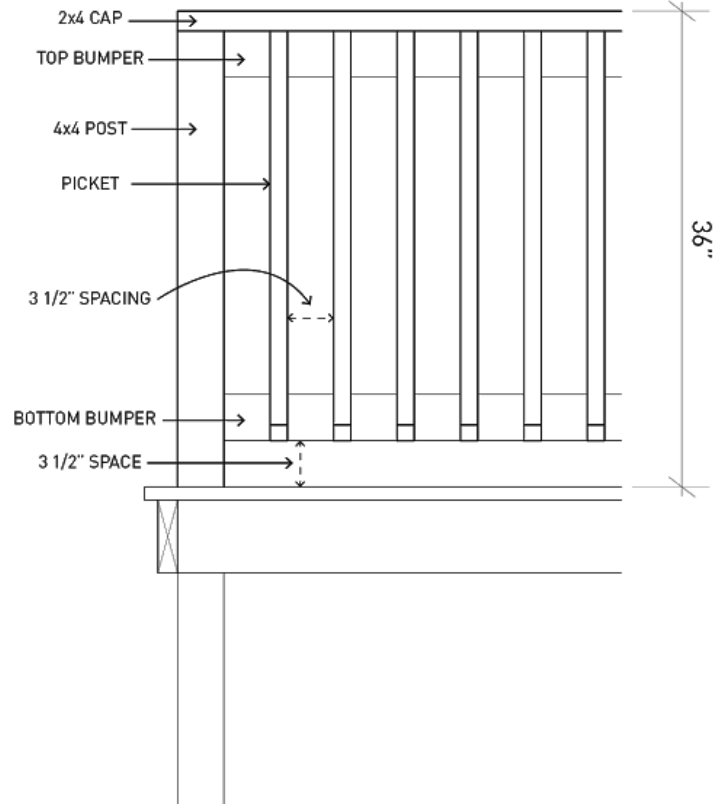

DIAGRAM 20-B

TOP VIEW

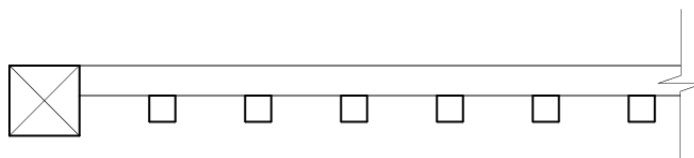
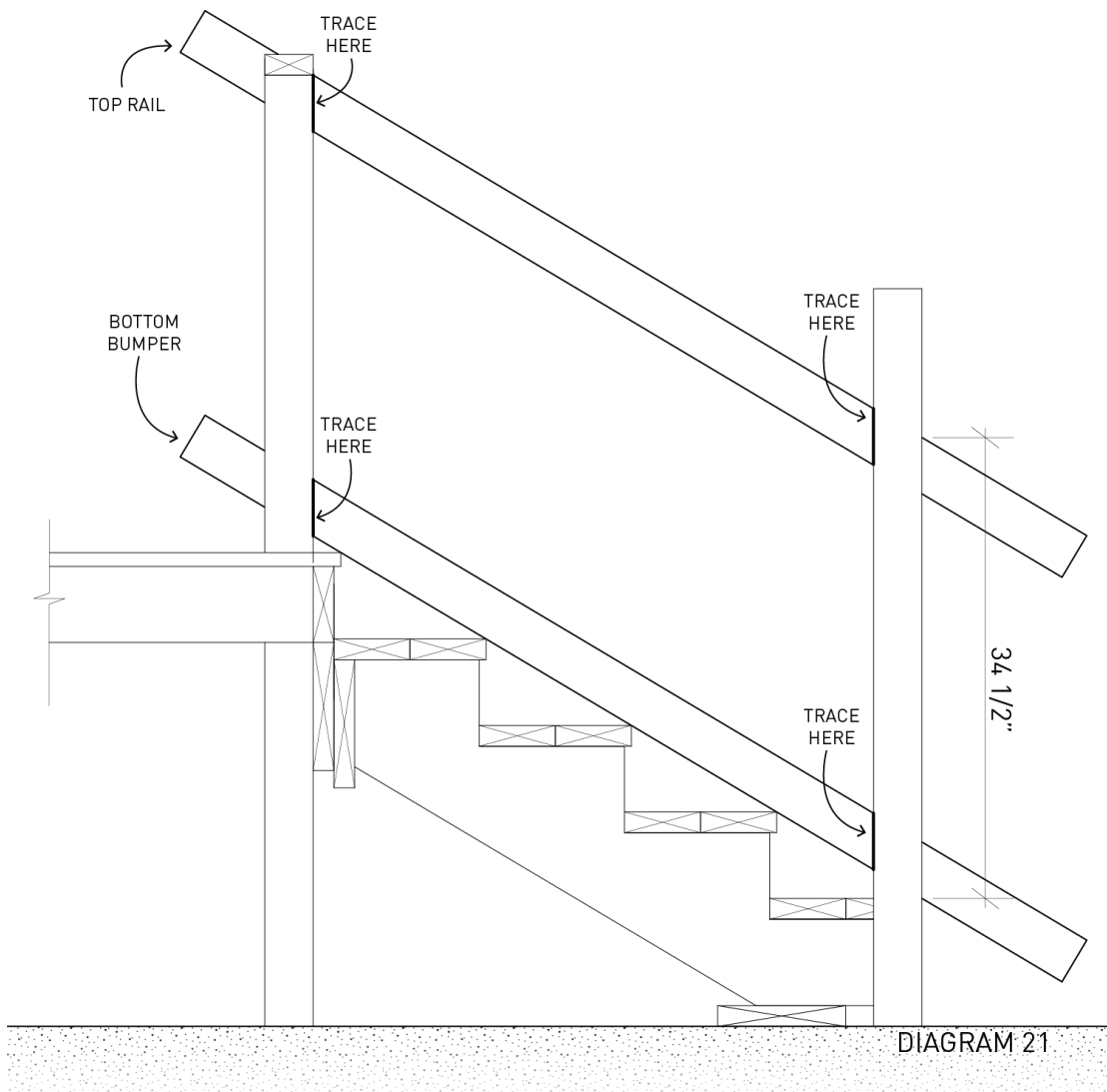

DIAGRAM 20-C



## Handrails on Stairs

- Bottom bumper will rest on the nose of each step (See Diagram 21)
  - Hold bottom bumper in place and trace the angle created at the intersection of the bumper and the posts at the top and bottom of the stairs
  - The bumper will rest in between the two posts
  - Attach the bumper by toe-screwing into the posts
- The height of the top bumper should be  $34 \frac{1}{2}$ " above the nose of each step (See Diagram 21)
  - Measure to determine height and placement of top bumper and trace the angle created at the intersection of the 2x4 and the posts
- Cut posts at bottom of stairs to height
  - Continue the line of the top rail onto the posts using a straight edge at the bottom of the steps, cut these posts to height (See Diagram 22)
  - Make the initial cut with a circular saw set to maximum depth, finish cut with reciprocating saw
  - Have someone in place to catch the top piece of post as it is cut



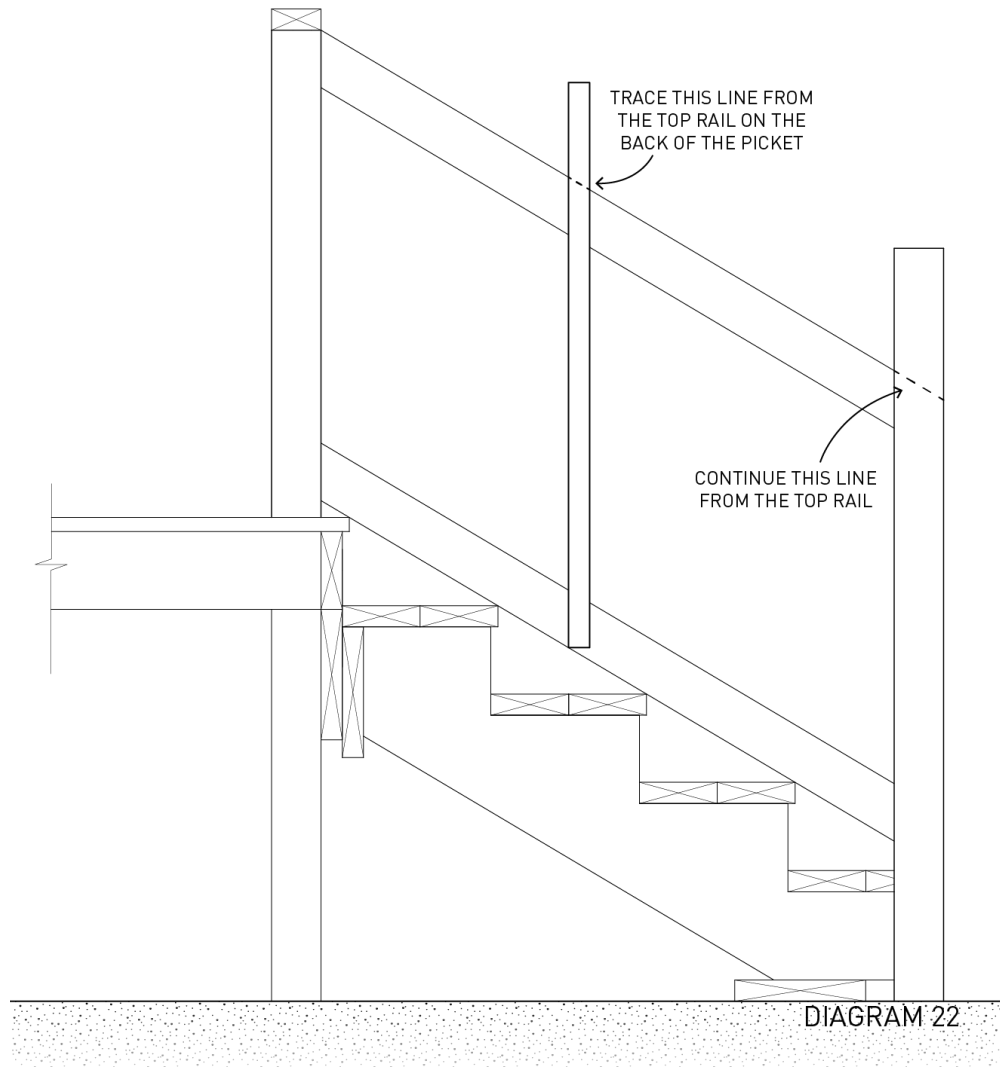

- o Install Pickets
  - Pickets will be spaced every 3 ½" (use width of a 2x4 block as a spacer)
  - Start in the middle of the stair bumpers and make sure the first picket is plumb
  - Hold the picket in place with the bottom of the picket at the bottom of the bottom rail and trace where the cut should be at the top of the top rail (See Diagram 23)
  - Match the angle of the cut on the miter saw and cut to length
  - Pre-drill pickets with ⅛" drill bits and install with 2 ½" deck screws
- o 2x4 cap over handrails (See Diagram 23)
  - Match the angle cut to that of the top rail by tracing the angle and matching it on the miter saw
    - Cut piece slightly long initially, and cut to exact length once the correct angle is found
  - Allow for a small overhang at the bottom of the handrail
  - Attach with 3" screws into the top rail/bumper

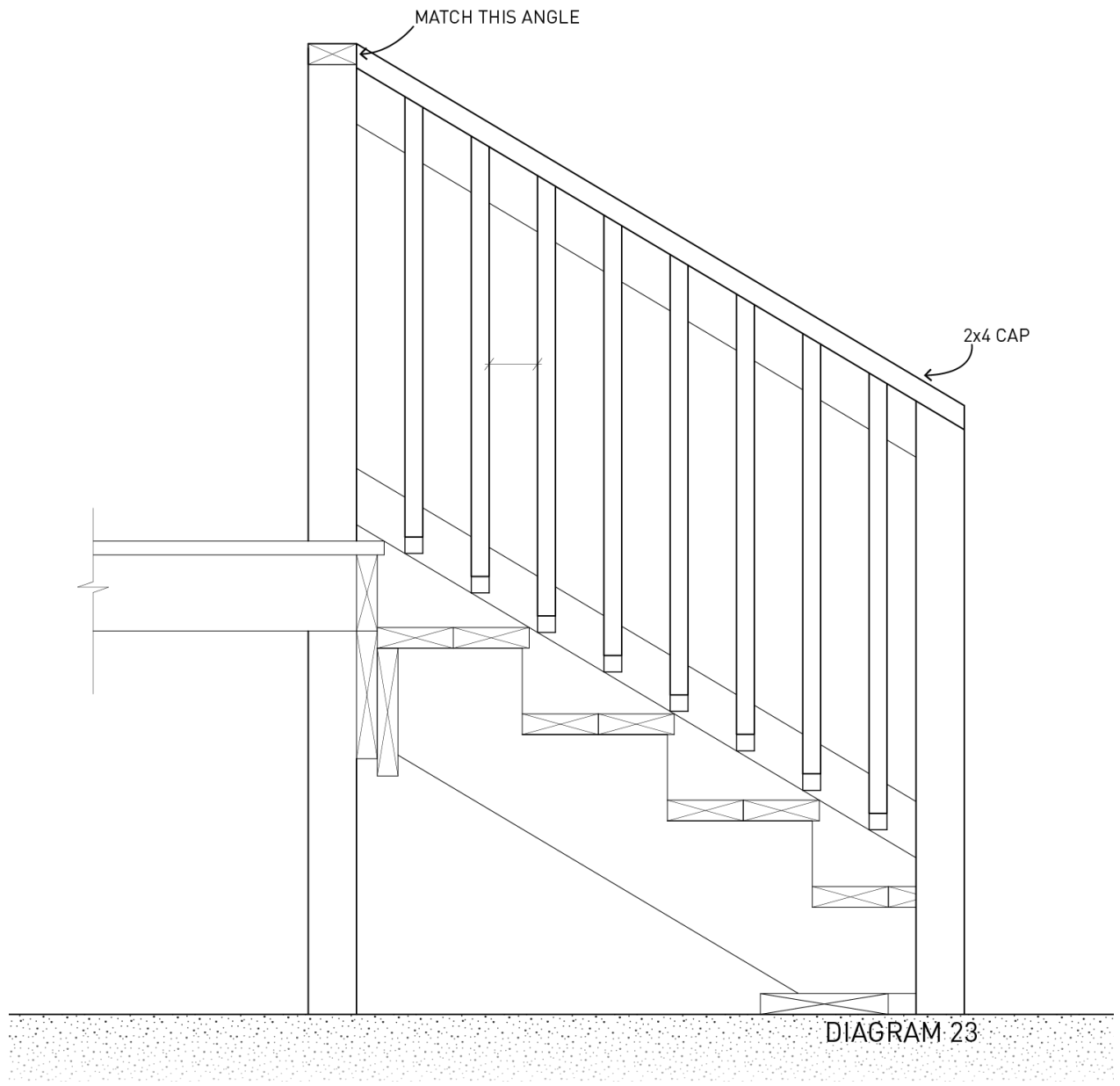

## Porch Materials List

| <u>Quantity</u> | <u>Item</u> | <u>Purpose/Notes</u> |
|-----------------|-------------|----------------------|
|-----------------|-------------|----------------------|

### Lumber:

#### **5'x5' Porch (Stair material not included - see below)**

|    |                     |  |
|----|---------------------|--|
| 5  | 4x4x___ PT (or 6x6) | Posts within frame   |
| 4  | 2x6x10 PT           | Exterior frame, common joists                                  |
| 2  | 2x4x8 PT            | Blocking, temporary supports, cross piece for bottom of stairs |
| 6  | 12' Deck Boards     | Walking surface over joists                                    |
| 2  | 2x4x12 PT           | Diagonal bracing   |
| 3  | 2x4x10 PT           | Top/bottom rail and cap around frame                           |
| 30 | Pre-cut Pickets     | For rails around landings                                      |

#### **6'x10' Porch (Stair/Handrail material not included - see below)**

|          |                     |  |
|----------|---------------------|--|
| 7        | 4x4x___ PT (or 6x6) | Posts within frame   |
| 6        | 2x6x10 PT           | 2 long exterior frame members, common joists   |
| 1        | 2x6x12 PT           | Cut in half for short sides of frame   |
| 2        | 2x4x8 PT            | Blocking, temporary supports, cross piece for bottom of stairs                             |
| 11       | 12' Deck Boards     | Cut in half for walking surface over joists  |
| 2 (or 3) | 2x4x12 PT           | Diagonal Bracing (Add third for diagonal bracing on center posts if porch is over 4' high) |

#### **6'x10' Handrails (if steps coming off of 10' side of porch)**

|    |                 |  |
|----|-----------------|--|
| 5  | 2x4x12 PT       | Top/bottom rail and cap around framing |
| 45 | Pre-cut Pickets | For rails around porch                 |

#### **6'x10' Handrails (if steps coming off of a 6' side of porch)**

|    |                 |   |
|----|-----------------|---|
| 3  | 2x4x10 PT       | Top/bottom rail and cap on the 10 side  |
| 3  | 2x4x12 PT       | Top/bottom rail full 6' side, top/bottom rail and cap in small section beside steps |
| 1  | 2x4x8 PT        | Cap on the full 6' side   |
| 45 | Pre-cut Pickets | For rails around porch  |

### **Stair Material (For both 5'x5' and 6'x10')**

|     |                           |  |
|-----|---------------------------|--|
| ___ | 2x12x___ PT               | <i>The length of piece needed for each step is one foot for each step plus one foot</i>                              |
| 1   | 2x10x10 PT                | Cross pieces for top and bottom of stairs, ledger board to hang stairs   |
| ___ | 2x4x___ PT                | Top/bottom rail and cap for handrails on stairs, (6 lengths of 2x4 the same as the required length for the stringer) |
| 1   | 4x4x12 PT                 | Cut in half for posts at bottom of stair handrails   |
| ___ | 2x6x___ PT or 2x12x___ PT | Stair treads, 2 pieces of 2x6 or 1 piece of 2x12 38"-40" for each stair tread  |
| ___ | Pre-cut Pickets           | For stair rails, <i>horizontal distance between posts for top and bottom of stairs (in inches)/5" = # of pickets</i> |

### **Other Materials/Fasteners**

#### **5'x5' Porch**

|       |   |  |
|-------|---|--|
| 6     | 4" Solid Concrete blocks                | Base for steps, 1/2 in each post hole  |
| 30-35 | Ledger Loks                             | Attaching posts to frame, stairs to frame, ledgers to posts, posts to stairs |
|       | 2 1/2" Deck Screws                      | To attach deck boards and pickets  |
|       | 3" Deck Screws                          | For all other framing  |
| 4     | 2x6 Joist Hangers<br>Joist Hanger Nails | For common joists (not in contact with posts)                                |

#### **6'x10' Porch**

|       |   |  |
|-------|---|--|
| 7     | 4" Solid Concrete blocks                | Base for steps, 1/2 in each post hole  |
| 45-50 | Ledger Loks                             | Attaching posts to frame, stairs to frame, ledgers to posts, posts to stairs |
|       | 2 1/2" Deck Screws                      | To attach deck boards and pickets  |
|       | 3" Deck Screws                          | For all other framing  |
| 6     | 2x6 Joist Hangers<br>Joist Hanger Nails | For common joists (not in contact with posts)                                |

## Recommended Tools

### **Safety:**

Glasses  
Gloves  
Ear Plugs

### **Digging Tools:**

Post Hole Diggers  
Shovels  
Digging Bars or Sledge Hammer to break blocks

### **General Tools:**

Basic Hand Tools (Tape measures, hammer, pencils, speed square, etc)  
Saw Horses  
Extension Cords/Splitters  
Framing Square - for laying out stairs  
4' Level  
Post Level  
Prybars - if deconstructing  
Marking Paint

### **Power Tools:**

Drills/Impact Drivers  
→ (2-3) 1/8" Drill Bits - to pre-drill handrails and pickets  
→ (3-4) T-25 Drivers for Deck Screws  
→ 5/16" Hex Drivers or T-40 Driver coordinating to heads of ledger loks  
Miter Saw  
Jig Saw - for notching around posts/finishing cuts in stringers  
→ Wood Blade  
Circular Saw - cut posts to handrail height  
Reciprocating Saw  
→ Demo Blade  
→ Wood Blade



# Ramps

**Why Ramps?** Ramps provide safe access to elderly and disabled homeowners and help them to have independence in their homes.

## Safety

- Wear gloves when removing debris/old structures
- Make sure to bend down or remove any nails sticking out of any debris lumber
- Wear safety glasses when cutting or working near someone cutting with power saw
- Communicate with homeowner/block off entrance if needed
- Put up temporary rails overnight if needed for homeowner to have accessibility
- Set up a cutting station facing away from the work area with plenty of space to maneuver boards

## Ramp Project Planning

- Is there adequate space for a ramp?
- While ramp is being built, will the family have another entrance/exit to the house?
- Are any utilities - water/electric in the area where the ramp will go?
- Should any other repairs be made to make the home safe and accessible for the family?
- Where will the ramp end?
- Will an initial landing/porch need to be built as well?
- Will you need to turn the ramp or have an extra landing to break up the length?
- Will any permits/inspections be needed?
- Does the ground slope towards or away from the ramp area? This may affect the length
- All ramp material will be pressure treated lumber
- **See additional ramp planning section below for ramp layout/design instructions**

## Measurements Needed

- Height off the ground - the ramp will drop 1" for every 12" of length
- Length of the ramp, number of the landings and turns that will be in the ramp

## Quality Control

- Are holes 16"x16"x 24"?
- Check for 41 ¼" space from the inside of one post to the inside of the other across the width of the ramp
- Check for 7'6" spacing from center of the post to center of the post going down the ramp
- Check for a consistent 1" drop for every 12" of ramp
- Make sure boards are crowned
- Check to make sure 2 ledger loks are used everywhere a ledger, runner, or joist meets a post
- Make sure finished rail height is 36"
- Make sure that spacing for pickets is 3 ½" and that pickets are plumb
- Make sure that there is a 1 ½" graspable handrail at the top of the handrail on ramp sections and a bumper at the bottom – for both pickets and barn rails

## Common Mistakes

- Holes not 16"x16" at the bottom
- Posts set too far apart so that ordered lumber for runners/rails will not reach
- Ramp is too steep
- Ledger loks forgotten on outside runners
- Posts cut off at finished handrail height
- **No smooth transition/concrete pad at the end of the ramp**

## After Work is Complete Quality Control Check

- If ramp does not end at a driveway/sidewalk pour a small concrete pad at the bottom of the ramp to help transition on/off of ramp
- Sand tops of handrails if needed
- Have other necessary handicap modifications made to the home?

## Group Leader Tips

- Getting the layout done and posts set is the hard part because there are a lot of moving pieces, hang in there!
- Some volunteers can split blocks while others are digging
- You can start digging holes for the second line of posts before the first is complete
- If there is a landing, once the first framing member for that is installed, some people can be installing the runners and ledgers for the first section of the ramp while others work on framing/joists for the landing
- Once the first section of runners are complete, decking can start to be installed at the top, even if all the framing hasn't been installed
- Some people can be pre-cutting decking while others are framing
- Handrails can be started at the top of the ramp once it is decked, while framing/decking are still happening at the bottom



# Ramp Instructions

## Ramp Planning

A ramp will drop 1" for every 12" in length. It is important to plan out the path of the ramp before construction so that the ramp will fit in the available space.

Consider where the ramp is ending with convenience to the homeowner, likely somewhere near the driveway. This will largely dictate the ramp's path.

A ramp should always have a minimum 5'x5' landing at its beginning. This may be a porch or landing that is built as part of the ramp, or it may be something pre-existing. (Note the beginning "landings" in Diagram 1 may be something that already exists).

There are several possible layouts for ramps:

- A straight ramp with less than 30' of dropping surface (anything longer must have an intermediate landing)

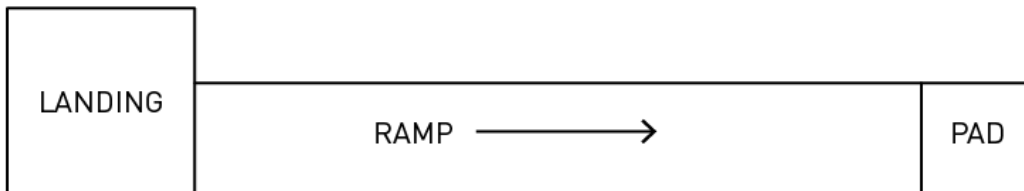

DIAGRAM 1-A

- A straight ramp with more than 30' of dropping surface with intermediate landing(s), intermediate landings are the same width as the ramp and 5' long

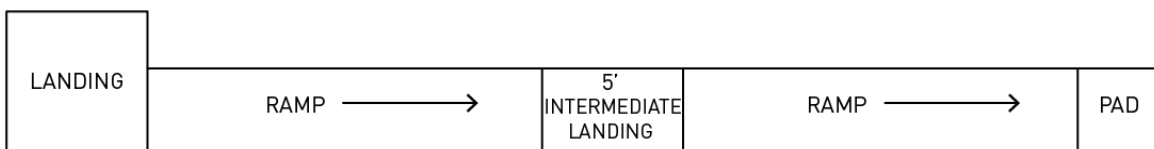

DIAGRAM 1-B

- A ramp with a 90 degree turn, with a 5x5 landing at the turn

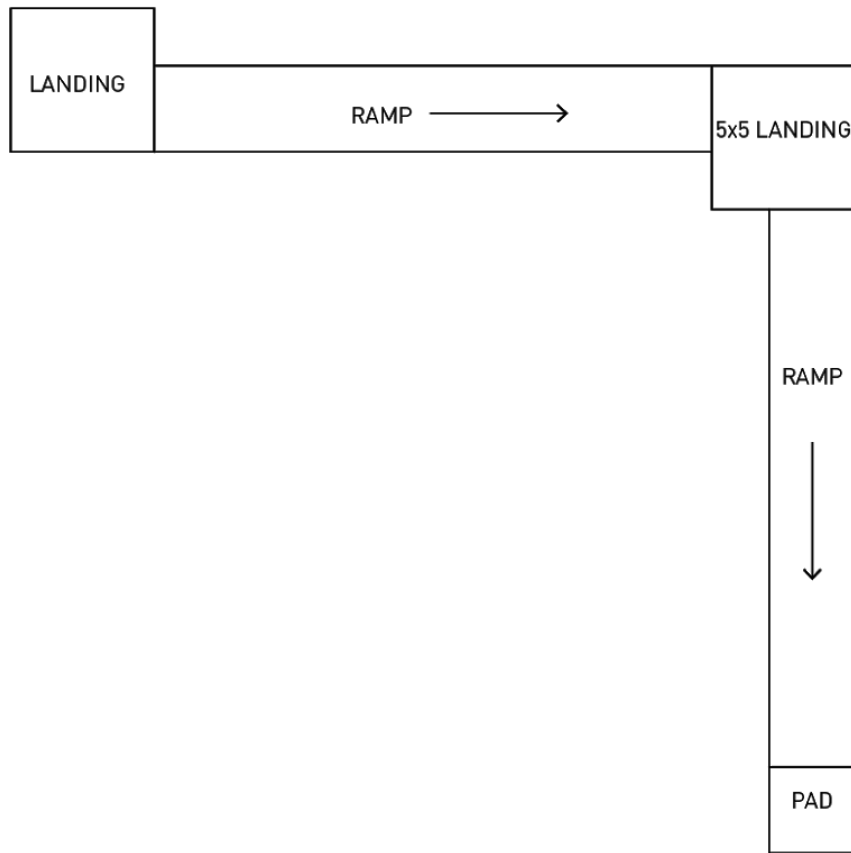

DIAGRAM 1-C

- A ramp with a 180 degree turn, with a 5x8 landing at the turn

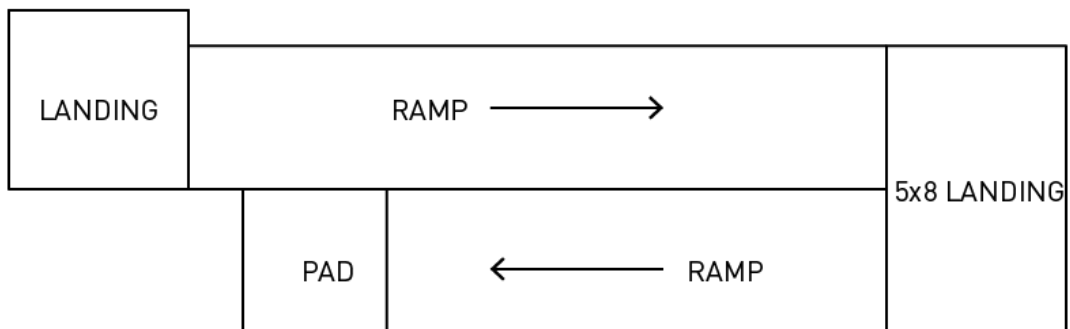

DIAGRAM 1-D

A ramp should be kept as simple as possible in the available space. Additional turns make the work more complex and costly, however, sometimes this is the only option for the space.

- Some additional ramp layout possibilities include (but are not limited to) a 180 degree and 90 degree turn (See Diagram 1E), or a 90 degree turn and an intermediate landing (See Diagram 1F)

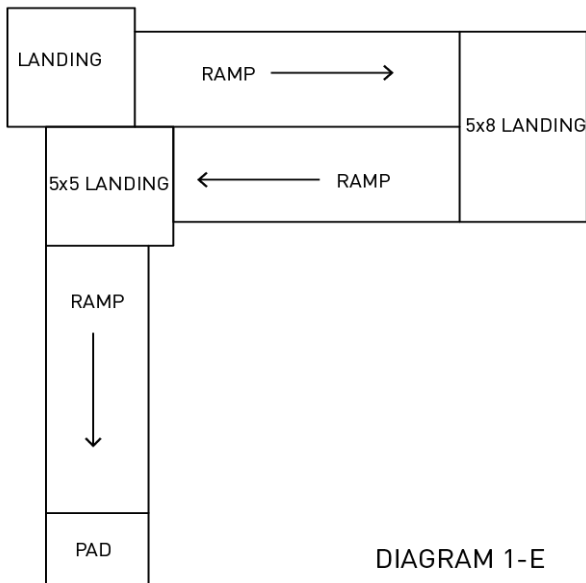

DIAGRAM 1-E

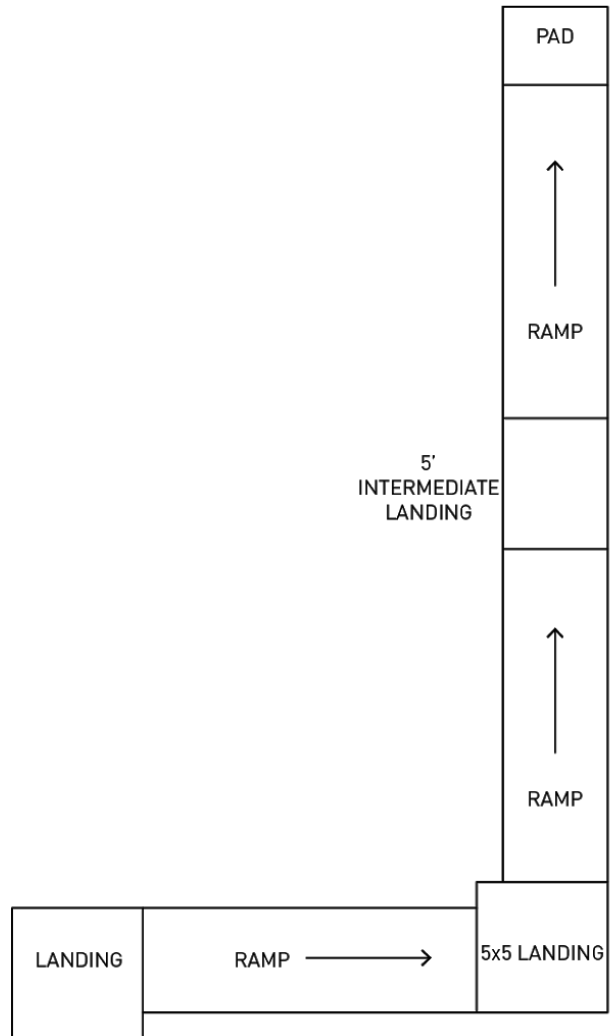

DIAGRAM 1-F

If there will be a 5'x5' landing or porch constructed at the top of the ramp, consult the porch section (See pages 225). Follow these instructions from beginning through handrails with the following change:

- An additional (5th) post will be installed for the ramp (as is with the stairs in the porch section), the space between these posts will be 41 1/4" across the width of the ramp (See Diagram 2)
- Common joists should be installed so that decking on landing is parallel to decking on ramp when it is added

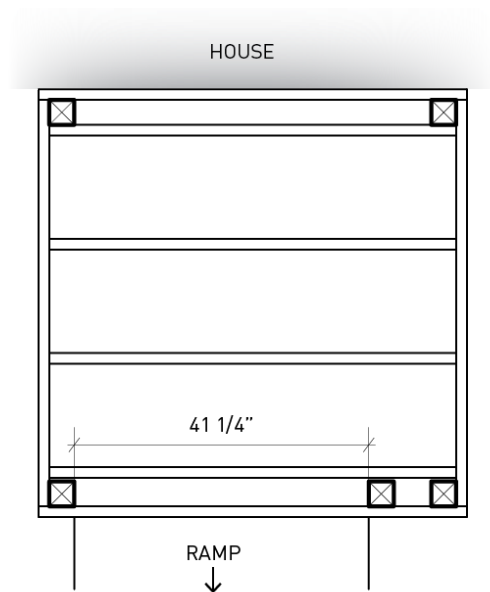

DIAGRAM 2

## Ramp Layout

- Posts will be installed in “lines”
  - All the posts in one line will be installed, then posts in the next line can be installed
  - The highlighted posts in Diagram 3A and B shows a “line” of posts

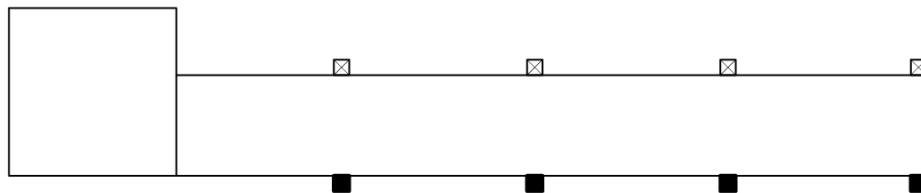

DIAGRAM 3-A

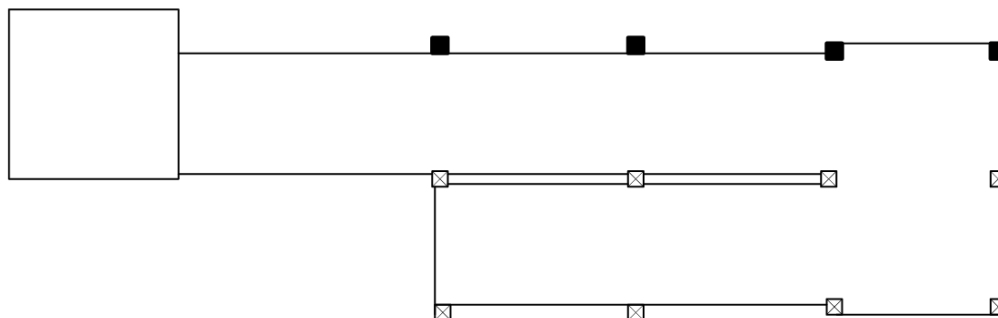
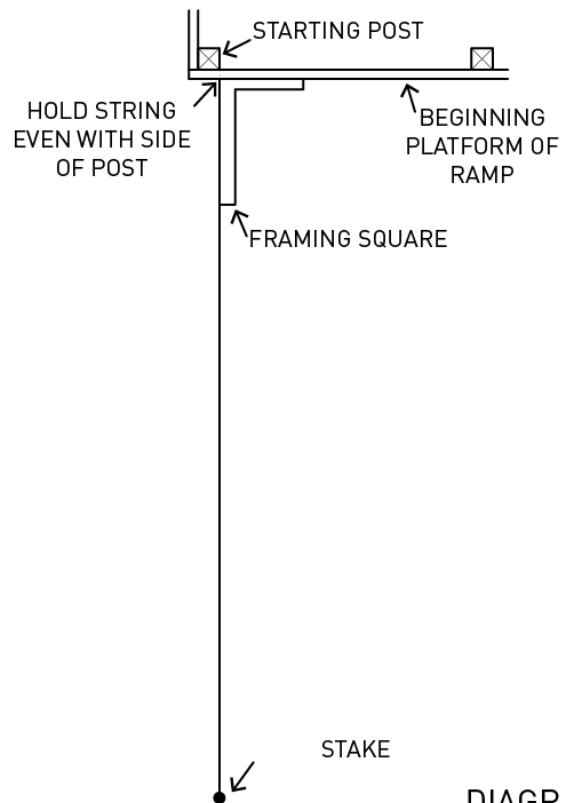

DIAGRAM 3-B

- All posts up through the ones that make the first landing should be set, then the process will be repeated for the next section of ramp
- Determine the spacing of the posts
  - **This will depend on the layout of each ramp**
  - For dropping sections of ramp, the posts should be spaced 7'6" on center along each line
    - When using 8' lumber, by spacing 7'6" there is some forgiveness and if any spacing gets a little off the 8' lumber still fits in the given space
    - Posts would be centered at 7'6", 15', 22'6", 30' (as applicable to each ramp)
  - Posts that make up an intermediate landing, 5'x5' turn, or 5'x8' turn should be spaced 4' 5 1/2" on center (50" OC)
- For the first line of posts, from the landing that will act as a starting surface (or a section of ramp coming off of an intermediate turn/landing):
  - Attach a string on the inside of the starting post (See Diagram 4)
    - Pull string in the direction of the drop of the ramp
    - Use a framing square to make sure that the string is square
      - Hold the framing square in place and move the string until it lines up with the edge of the framing square
    - Tie the string off to a stake that is driven into the ground
      - Make sure string remains square



- Mark where holes will go based on ramp plan
  - The string as shown in Diagram 4 indicates the inside of the line of posts
  - Use spray/marketing paint to mark the center of each hole

**Example for marking out posts:**

Layout for ramp:

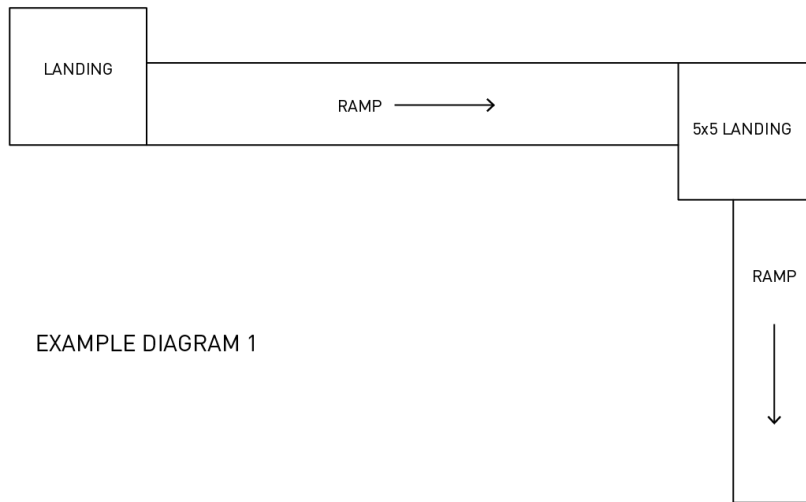

EXAMPLE DIAGRAM 1

The highlighted posts in the diagram below are the first line of posts that will be set

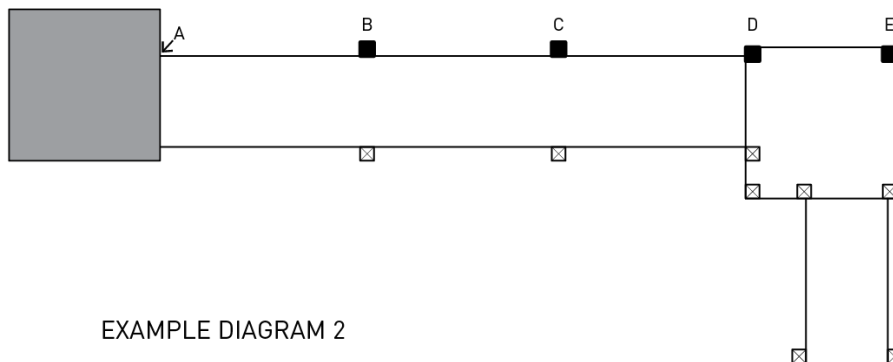

EXAMPLE DIAGRAM 2

From point A to point D will be 22'6" long. (Points B,C,D, and E mark the center of each post)  
 From point A to B will be 7'6", B to C will be 7'6", C to D will be 7'6", D to E will be 4'5 1/2".

Therefore, spray paint marks will be made along the string (measuring from point A) at 7'6" (B), 15' (C), 22'6" (D), and 26'11 1/2" (E).

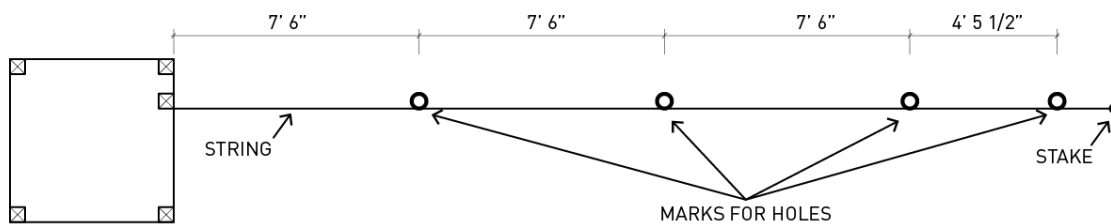

EXAMPLE DIAGRAM 3

## Dig Holes and Set Posts

- Leave the stake in the ground, but temporarily remove string to dig holes
- The spray paint mark should indicate the center of the hole
- Holes will be dug 16"x16"x24"
  - Tamp the dirt in the bottom of the hole flat
- Place either a split cap block or 3" of dry sackrete in the bottom of each hole
  - For cap blocks, split with digging bar or sledgehammer, place half of a cap block in each hole, and make block level (See Diagram 6)
  - For sackrete, after pouring in 3", tamp down and make flat with sledge or digging bar

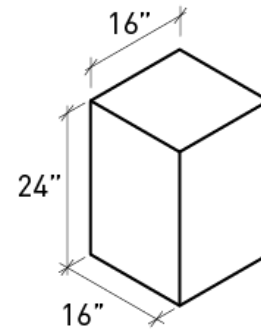

DIAGRAM 5

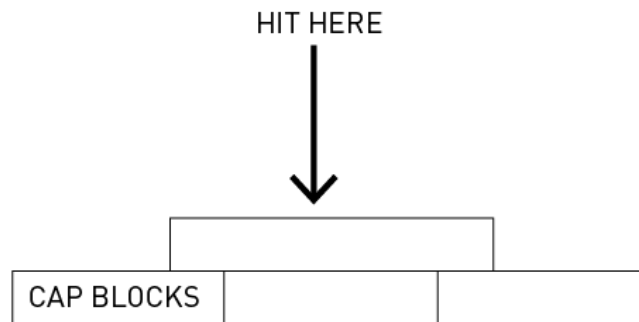

DIAGRAM 6

- Post will sit directly on the cap block or sackrete
- After all holes in a line are dug, re-attach the string to the stake and double check for square to the landing
  - Make sure string is pulled tight
- Start by setting the first post in the line (The left side of Diagram 7 shows the first line of posts)
  - The post should be in place with one edge barely touching the string (do not let the post lean into the string so that it is no longer straight)
    - Make sure the post is on the correct side of the string, in line with the post from the landing/porch
  - Use a level (or post level) to make sure post is plumb in both directions
  - From the edge of the landing to the center of the first post should be 7'6"
  - **When the post is lined up with the string, plumb, and 7'6" from the landing, start to fill in the holes with dirt**
    - If the hole needs to be adjusted to meet these criteria, remove the post and widen the hole as needed

- Fill holes with several inches of dirt at a time and tamp tightly
- Set the next post in line
  - Like the first, make sure that the post is lined up with the string, plumb, and at the correct distance from the center of the previous post
- Set remaining posts in line repeating this process
- As each post is set, step out towards the stake and look back down the line of posts
  - They should all disappear behind the one closest to you if they are lined up correctly

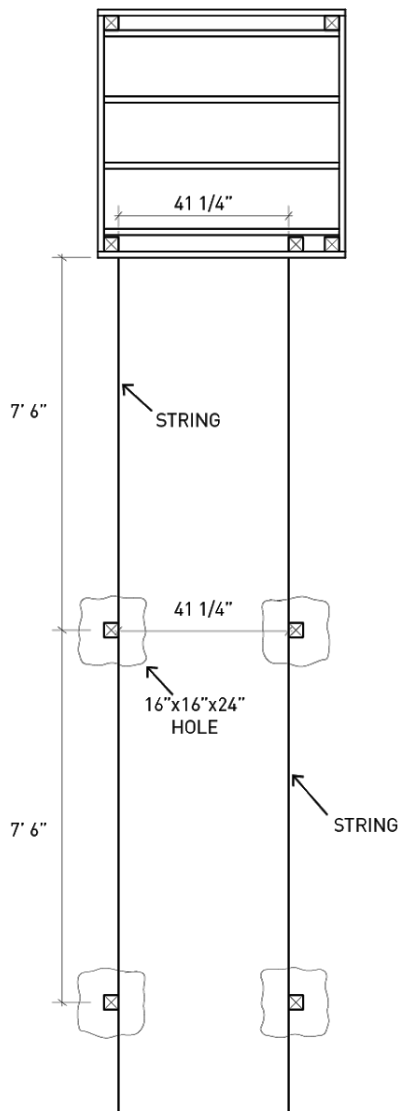

DIAGRAM 7

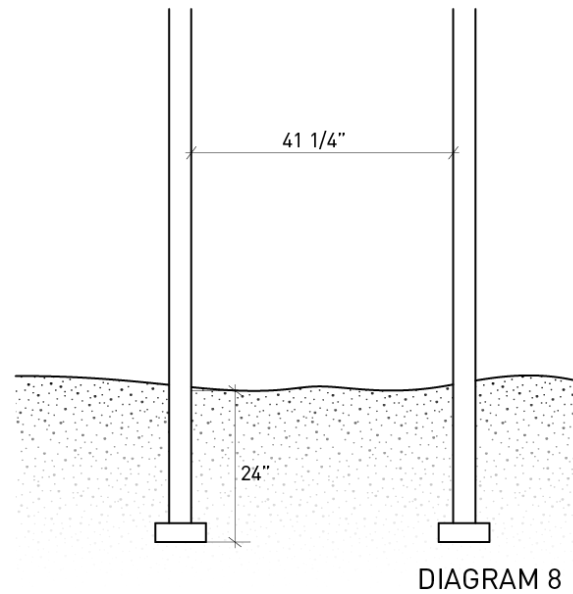

DIAGRAM 8



- Prepare the second line of posts (See Diagram 7 and 8)
  - For this line of posts, attach another string (lined up with the inside of the starting post) and square it, securing it to a stake as was done for the first line
    - **The distance from the inside to inside of each set of posts moving down the ramp is 41 ¼"**
  - Mark the holes, dig, and put in cap blocks or sackrete as done before
- Setting the second line of posts (See Diagram 7 and 8)
  - Follow the same process as for the first line of posts
  - **Additionally, make sure that as posts are set there is a 41 ¼" space from the inside of posts in the first line to the inside of posts in the second line**
  - Continue until all posts in line are set
- Follow the same procedure for any additional lines of posts that form a sloping portion of the ramp

### **Landing Frame (if applicable):**

- **Starting at the top of the ramp the runner will drop 1' for 12' of length**
- Use string and line level from the top of point where the first runner will start at the porch/landing
  - If initial landing is already decked, drop string 1" to account for the thickness of the decking that will be added on top of the runners, to ensure a smooth transition
- Run string to the first post in the landing/turn and mark at level
- Measure down from this level mark and make another mark at how many inches of drop there should be for this section of the ramp
  - **The number of inches dropped is equal to the distance in feet of the dropping section of the ramp**
- Diagram 9 demonstrates this process with two sections of ramp that are dropping over a 15' section
- Repeat this process on the second line of posts

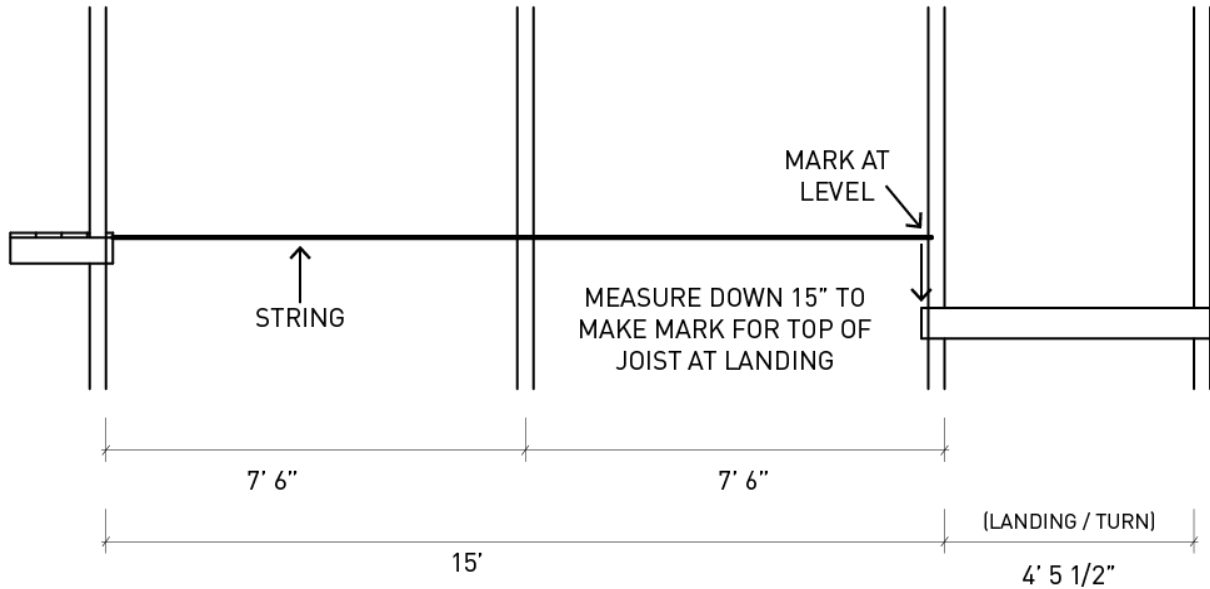

DIAGRAM 9

- Install a 2x6 across the posts at the bottom of the dropping section of ramp (and any others that make up this side of the landing/turn - See Diagram 10C) so that the top of the 2x6 lines up with these marks
  - Make sure this board is level
  - Attach board with 2 ledger loks into each post
  - Diagram 10 shows the outside frame for a intermediate landing, 5'x5' turn, and 5'x8' turn, with the highlighted member being the first installed at the marks made using the string level
- Add additional framing members, using a level to carry them around the posts (See Diagram 10)
  - Where each 2x6 intersects a post, attach with 2 ledger loks

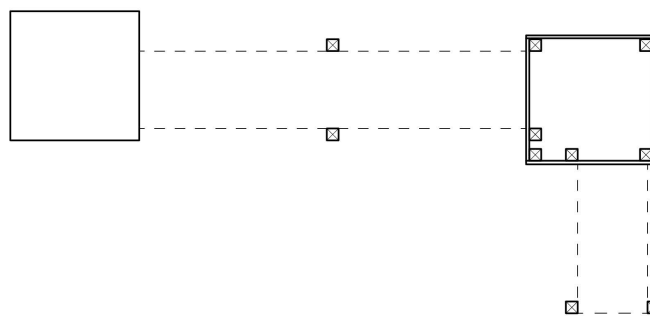

DIAGRAM 10-A

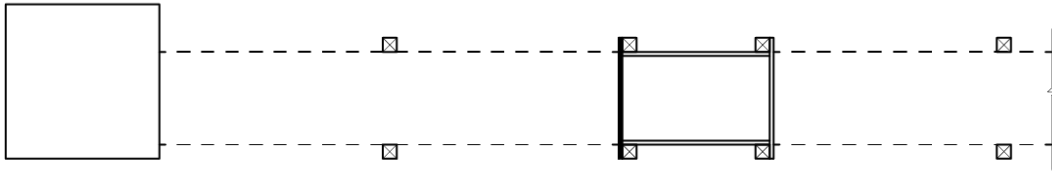

DIAGRAM 10-B

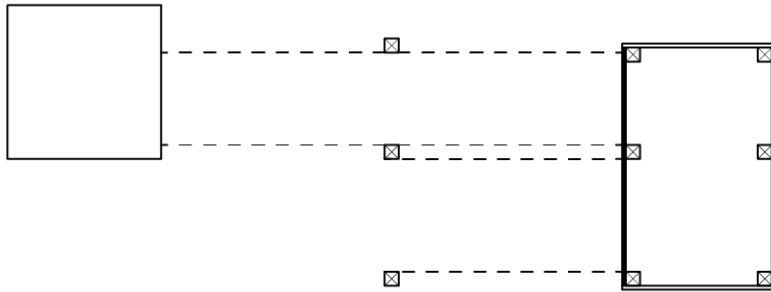

DIAGRAM 10-C

- Install the joists in the landing/turn (See Diagram 17 for common joist layout of each landing)
  - Install common joists every 16" on center
  - Measure and install each common joist with deck screws through the band joist
  - Make sure joists are flush with the frame at the top
  - Once each joist is in place, add a 2x6 joist hanger using joist hanger nails in holes on the flat surface and 2 ½" deck screws through the diagonal holes
- Add blocks (cut from 2x4) to each post in landing to provide a bearing surface for decking (See Diagram 11)
  - Make sure to pre-drill the holes in these small pieces to prevent them from splitting

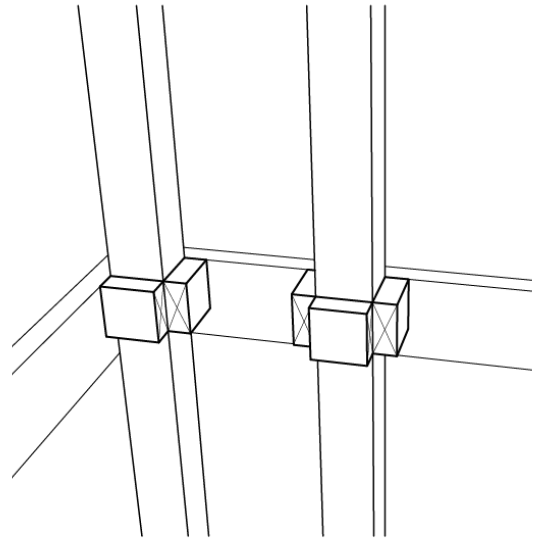

DIAGRAM 11

## Outside Runners:

- Runners are 2x6s that will act as joists on the dropping ramp
- Starting at the top of the ramp the runner will drop 1' for 12' of length
- The angle for where the runner meets a landing is 5°, cut both ends of runners at this angle
- Make sure runners are dropped 1" from the surface of the landing/porch so that when the decking is added the transition will be smooth (if tying into an existing landing)
- Runners will be installed on the **inside** of each line of posts (See Diagram 12)
- Check the slope of the runners as they are installed
  - A 2x4 block can be taped to a 4' level at 42" (See Diagram 13)
    - The 3 1/2" to 42" ratio is the same as the required 1" to 12" for the slope of the ramp
    - With the level and 2x4 block sitting on top of the runner, the runner is at the correct slope when the level/block assembly reads level

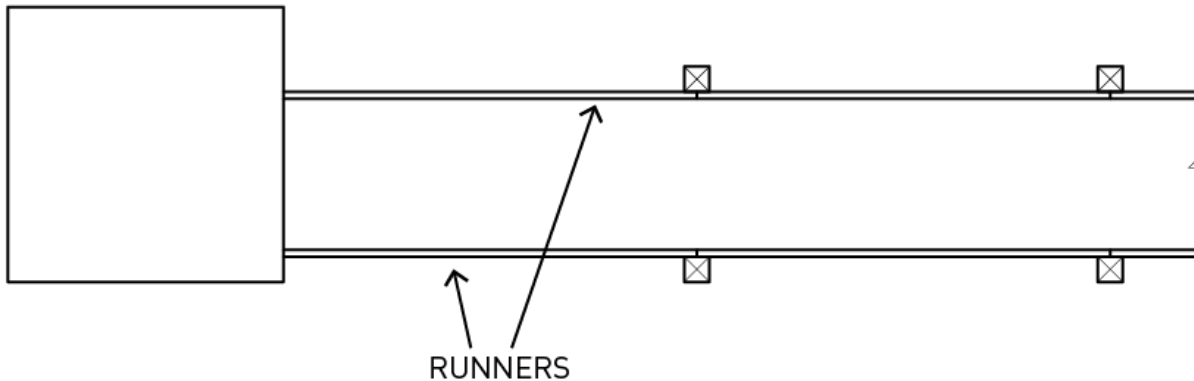

DIAGRAM 12

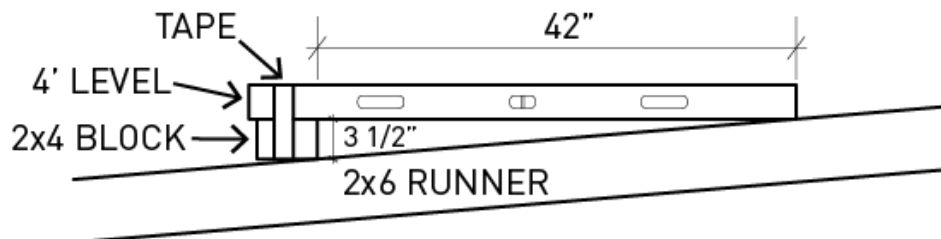
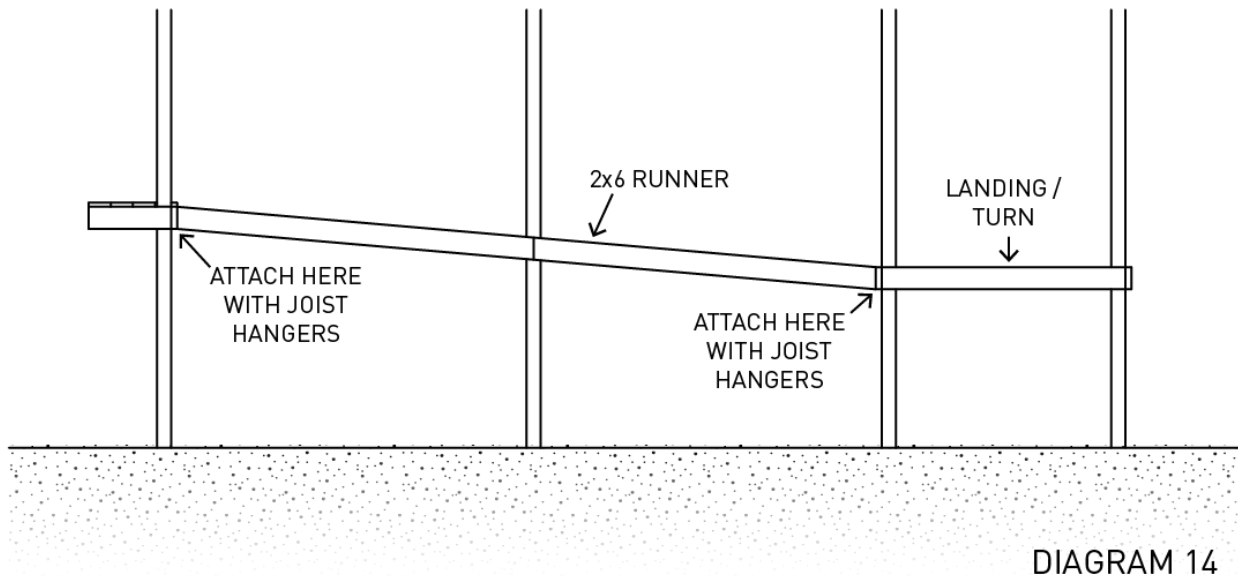

DIAGRAM 13

- Where runners meet at posts, they should be butted together and flush to one another at the top
- Runners should be attached to each posts with 2 ledger loks but can be temporarily attached with screws until they are adjusted to the correct place
- Use joist hangers where runners meet landings
- Make sure that where the runners intersect with the landing that the runners are flush at the top



- Follow the same process for any additional sections of ramp

### **Ledger Boards and Center Runners**

- Ledger boards are cut from 2x6s
- These will rest snugly underneath and perpendicular to the runners and connect pairs of posts together (See Diagram 15 and 16)
- Attach ledger boards to posts with 2 ledger loks to each post
- A ledger board should be installed on both sides of each set of posts, butted up to the bottom of the runners
- Install center runners (See Diagram 15 and 16)
  - Cut both ends at 5°
  - Set on top of ledger boards and tack into place using screws
  - Make sure that the center runner is directly in the center of the opening
  - Make sure that where sections of center runner butt together over ledger boards, the tops are flush

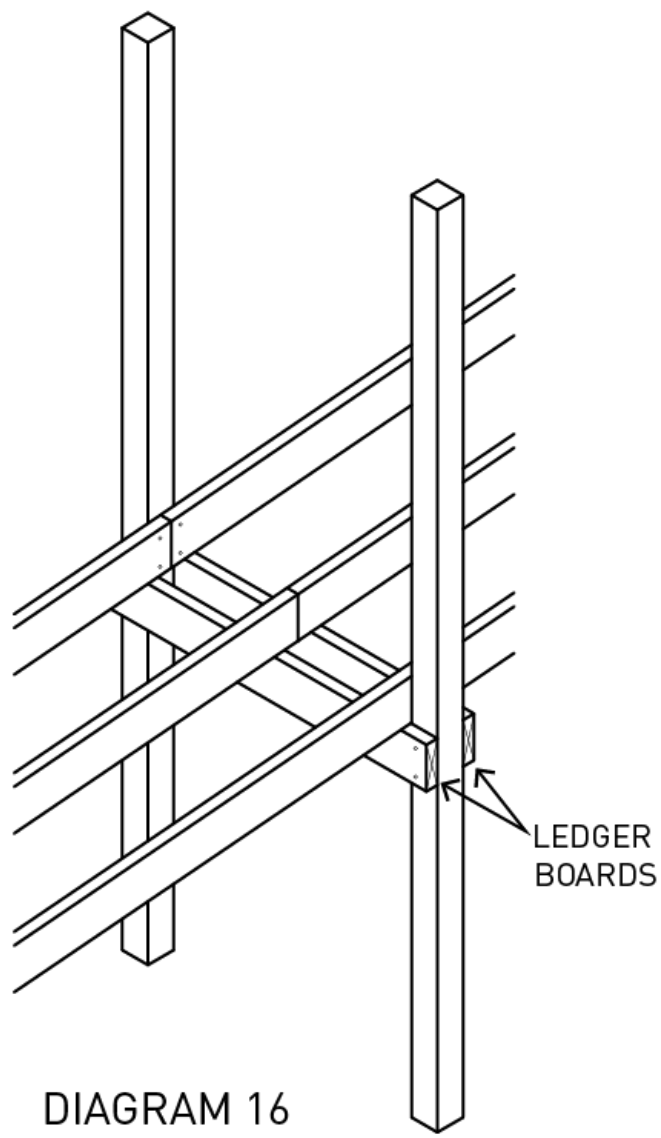
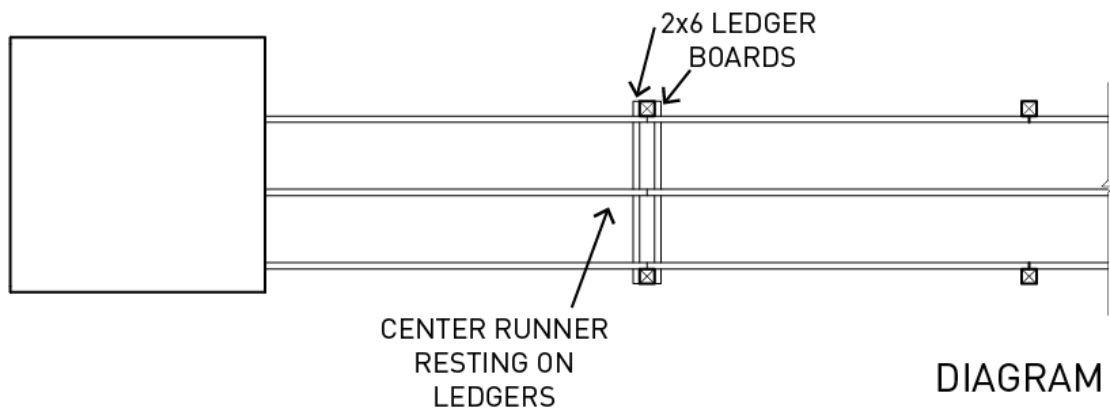

Diagram 17 A,B, and C illustrate several possibilities of framing for different ramp layouts. Other variations/combinations of these are possible.

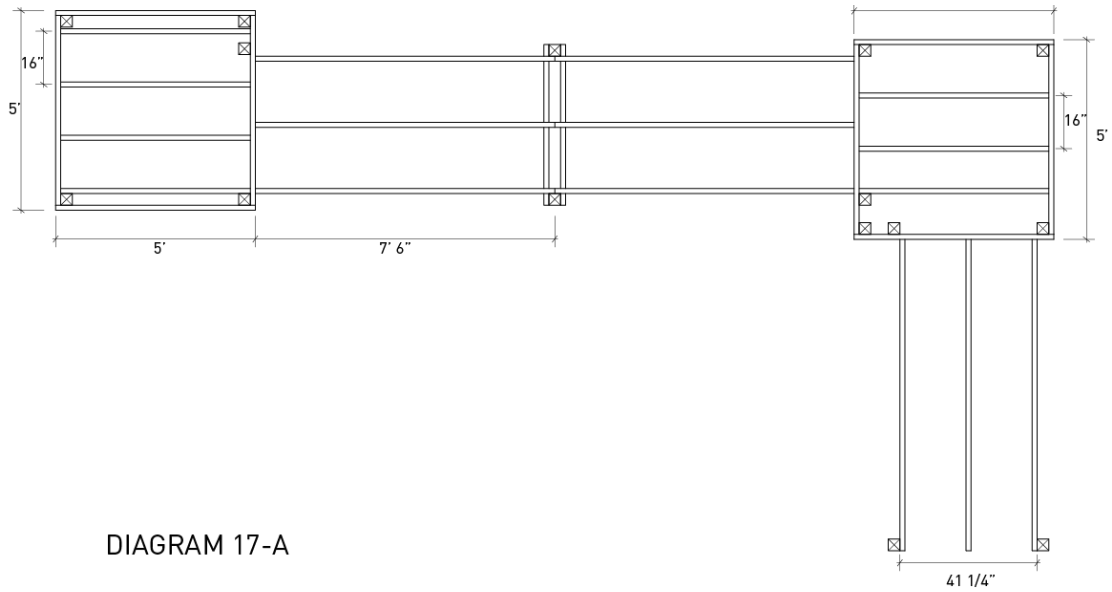

DIAGRAM 17-A

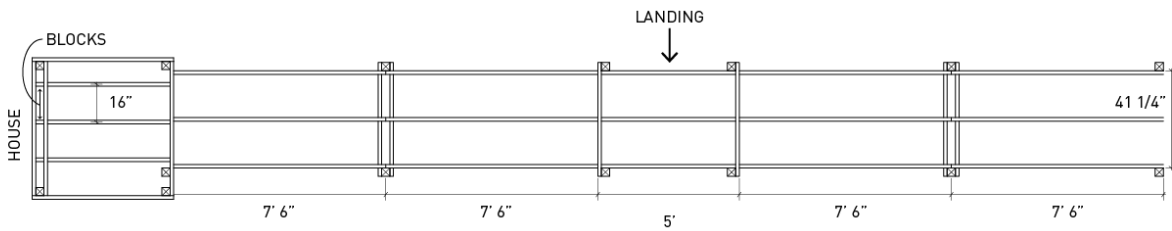

DIAGRAM 17-B

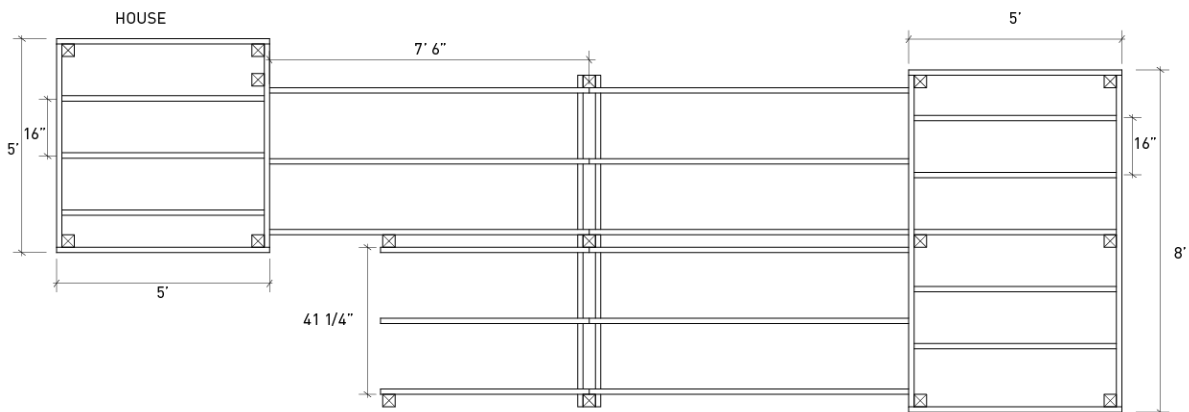
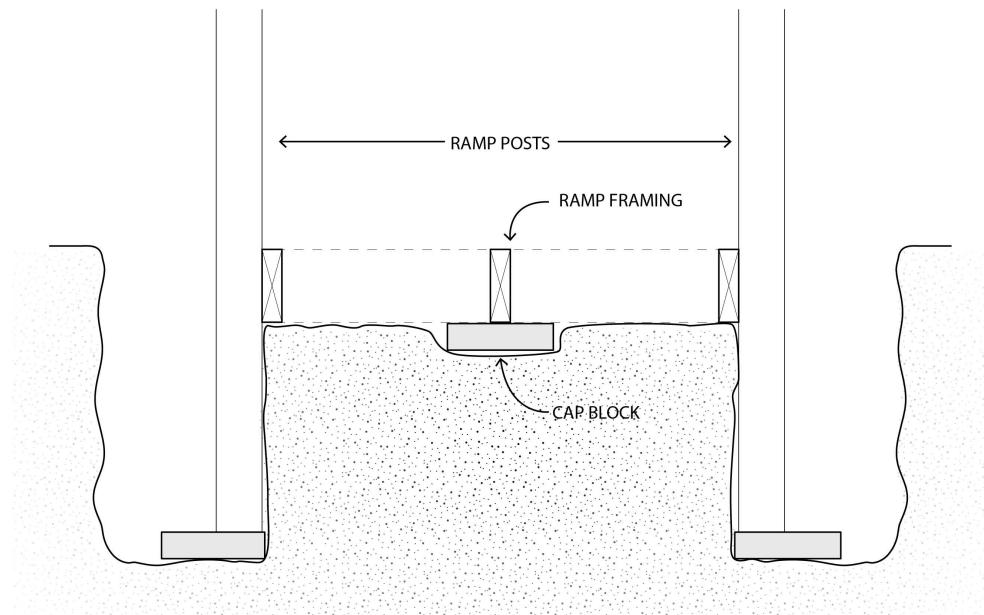

DIAGRAM 17-C

## Transition from ramp to ground:

- When transitioning from ramp to ground, enough dirt will need to be removed to allow ramp to maintain the proper slope for a smooth transition to ground level.
- In addition, post holes will be needed at the end of the ramp.
- Attach outside runners to posts and attach a 2x6 to the ends of the runners. This will act as a band joist to catch the middle runner.
- The middle runner should also be supported by a cap block.
- If ground contact lumber is available it should be used for this section of the ramp that is in contact with the ground.





## Decking

- Decking will run perpendicular to the runners/joists
- Allow for a 1" overhang of the decking on the ramp and landings
- Crown boards when installing by looking at the end grain of the boards (this helps water to run off rather than sitting on the wood) (See Diagram 18)
- Notch around posts using a jigsaw (See Diagram 19)
- Put two screws through the deck board into each runner about 1" in from the edge of the deck board (See Diagram 19)
- Do not leave any spaces between the boards, as the treated lumber dries out it will shrink and small gaps will form to allow water to run between
- If the runners are not perfectly square, decking may need to be cheated in one direction (rather than lining up decking edges perfectly) so that decking still covers the outside runners
- As an alternative method, decking pieces can be pre-cut to 48" and installed with relatively even overhang on each side, after decking is installed a chalk line can be used to mark a 1" overhang and decking can be cut at that mark



DIAGRAM 18

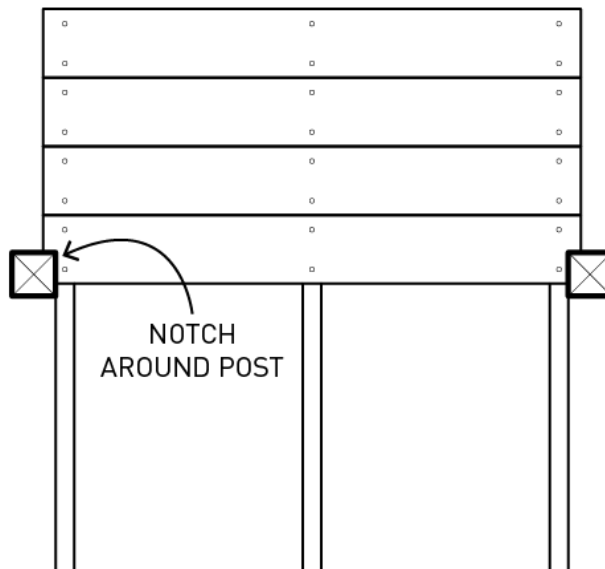

DIAGRAM 19

## **Railings**

- There are two different methods of railings for ramps: barn rails and spindles
  - Spindles are required for any ramp 32" or higher off the ground
  - Barn rails can be used for any ramp less than 32" off the ground
- For 5'x5' and 5'x8' landings, the handrails will be different than those on the sections of ramp, for a 5' straight intermediate landing, the rails will be the same as the dropping sections of ramp

### **Spindle Railings** (See Diagrams 20 and 21)

- Cut posts
  - On landings cut posts off flat at 34 ½" above the decking
  - For posts along the dropping section of the ramp, mark 33" above the decking on the first and last post (on the uphill side) and use a chalk line to transfer that line across all posts on the dropping section
    - Cut off posts at this angle using a circular saw at maximum depth and finishing cut with a reciprocating saw
    - Make sure someone is there to catch the top piece that is being cut off
- Around landings refer to directions in "Porch" section on page 257
- For dropping sections of ramp:
  - Install a 2x4 bottom bumper
    - This will start at the inside of the first set of posts at the landing/porch
    - Cut both ends at 5°
    - Bumpers will run on the inside of the posts (like the runners)
    - This bumper will rest 3 ½" above the surface of the deck boards (use a 2x4 block for spacing)
    - Attach with 3" deck screws
  - Install a 2x6 top rail
    - Like the bottom bumper, this will start at the inside of the first set of posts at the landing/porch, cut both ends at 5°, run on the inside of the posts, attach with 3" deck screws
    - Install this 2x6 sticking 3" above the tops of the cut posts
  - Install 2x4 cap that will lay flat and cover the tops of the 4x4 posts, and eventually the ends of the pickets
    - If needed, install a block at the top and bottom for this cap to rest on (See Diagram 20)
    - Make sure that joints in this cap are over a post
  - Install spindles
    - Install every 3 ½" (2x4 width can be used at top and bottom as a spacing block)
    - Cut pickets to length (measure from bottom of bottom rail to bottom of 2x4 cap)

- Top of the spindles can be cut at a 5° to match the slope of the top rail
- Pre-drill holes in pickets with 1/8" drill bits, and install with 2 1/2" screws
- Start in the middle of each section of ramp and work to either side, making sure the center picket that is installed first is plumb

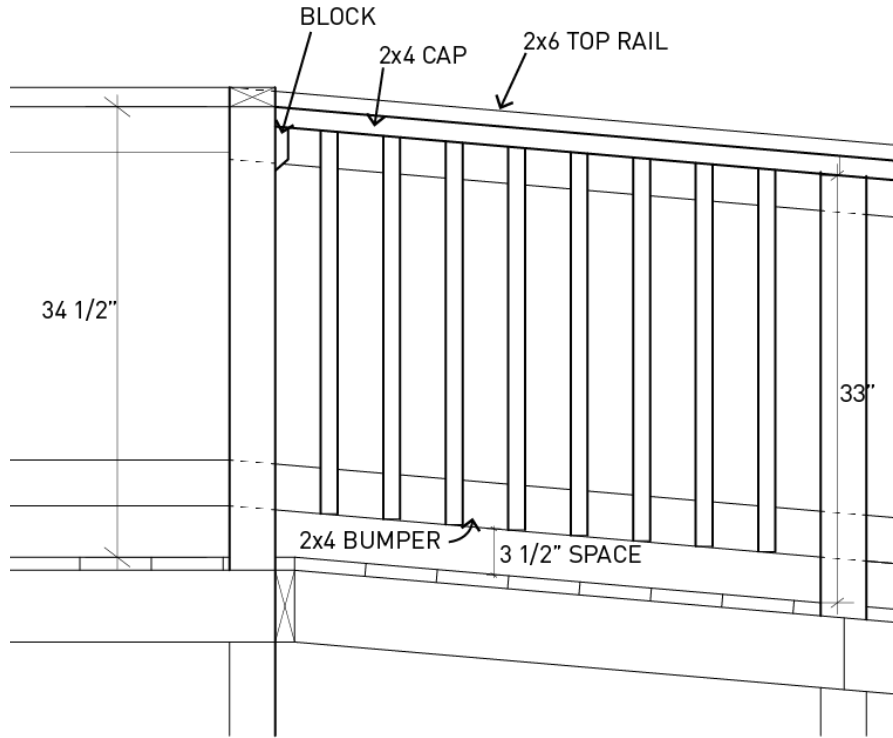

DIAGRAM 20

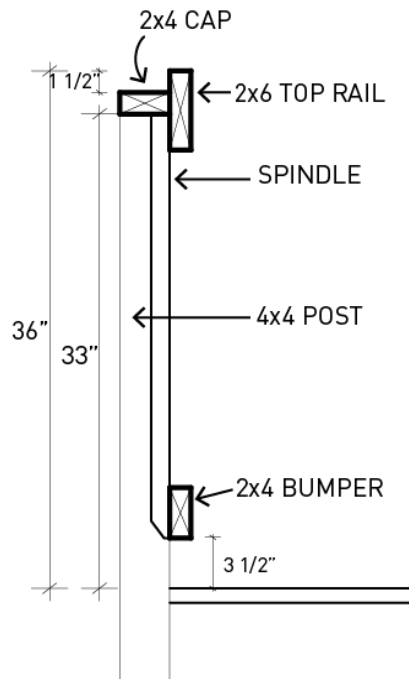
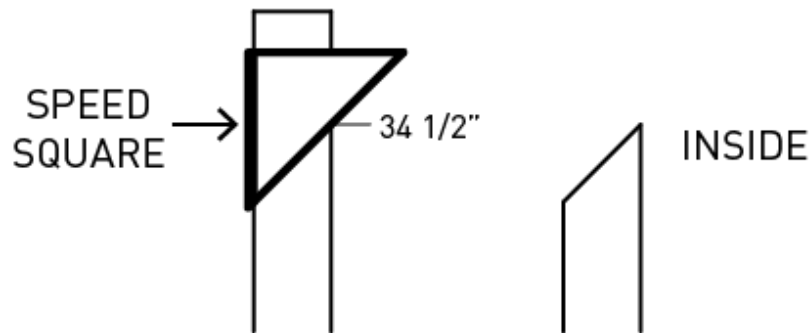

DIAGRAM 21

## **Barn Railings**

- On landings, cut posts off flat at 34 ½" above the decking
- For posts along the dropping section of ramp, measure 34 ½" above the decking on the uphill side of each post
  - Transfer lines around post with speed square and cut post at a 45° angle (See Diagram 22 and 23)
    - Can make the first pass of cut with a deeply set circular saw and finish with the reciprocating saw
    - Make sure someone is there to catch the top of the post as it is cut off



**DIAGRAM 22**

- Attach 2x6 handrails/bumpers down the ramp on the inside of the 4x4 posts using deck screws (See Diagram 23 and 25)
  - For top rail let 2x6 stick up 1 ½" above the tops of the posts
  - Install a 2x6 bottom rail 3 ½" above the decking (can use a 2x4 turned on edge as spacing)
  - Install an additional 2x6 between the top rail and bottom bumper
- Around landings (Diagram 24 and 25)
  - Install 2x6 rails (top, middle, and bottom) matching the height of those on the dropping sections of ramp
    - The top rail will not completely line up because of the additional 2x4 cap around the landing
  - These will be cut and installed between posts rather than on the insides (as shown in diagram 24)
  - Install a flat 2x4 cap, covering the top of the posts
    - Cut 45° angles at landing corners

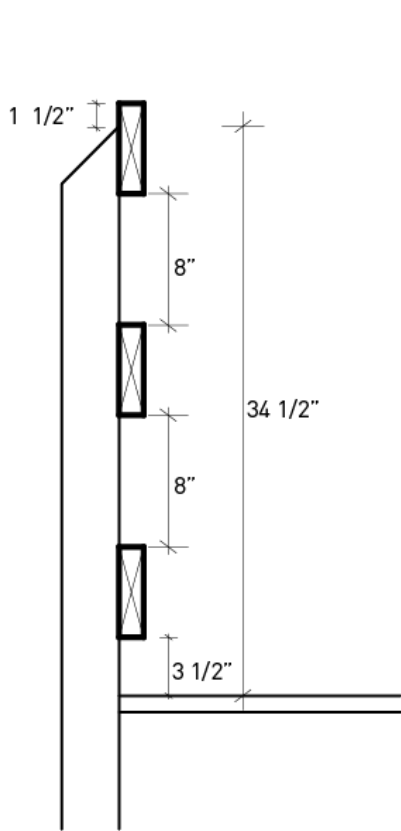

DIAGRAM 23

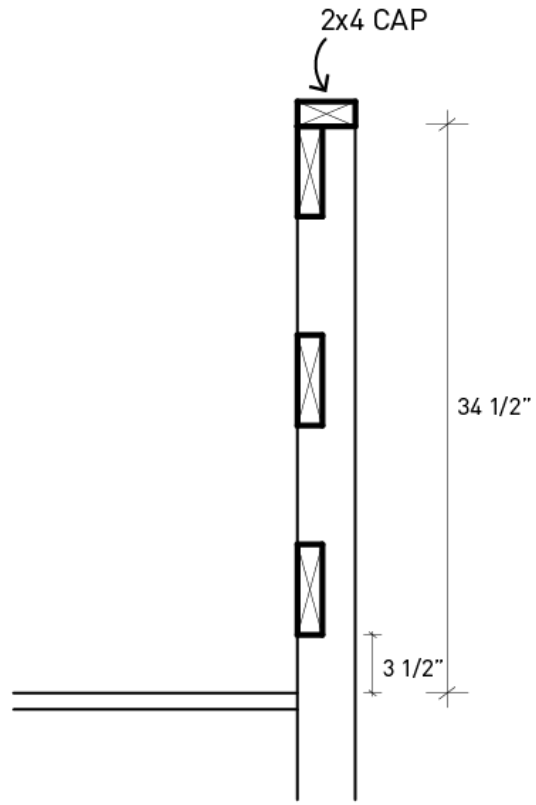

DIAGRAM 24

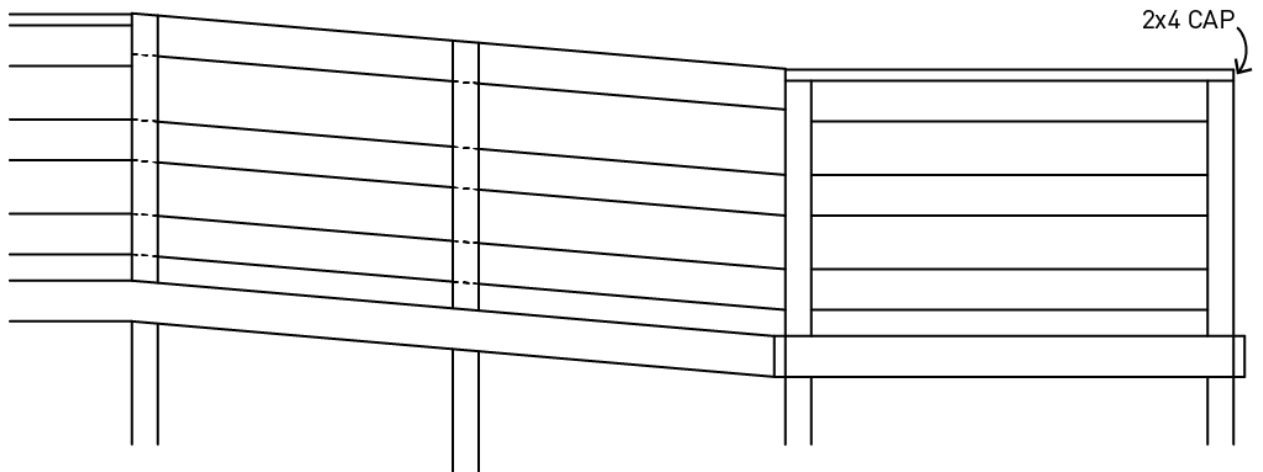
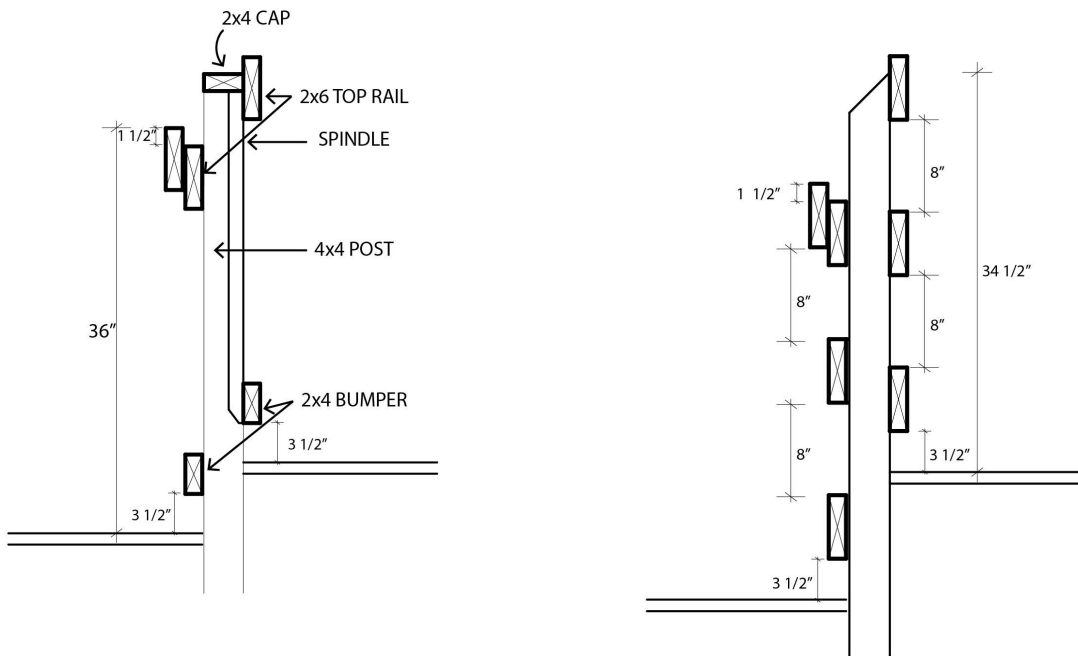

DIAGRAM 25

## Railings for Ramps that turn 180 degrees

- An additional 2x6 top rail will be needed for both spindle and barn rail style ramps that turn 180 degrees.
- This additional 2x6 allows space for the top rail to be graspable on the lower sections of ramp.
- Posts spaced at  $41\frac{1}{4}$ " will allow for this while still maintaining minimum clearance of 36".



## Ramp Material List

| <u>Quantity</u> | <u>Item</u> | <u>Purpose/Notes</u> |
|-----------------|-------------|----------------------|
|-----------------|-------------|----------------------|

### Lumber:

#### 5'x5' Landing/Turn

|        |                     |  |
|--------|---------------------|--|
| 5 or 4 | 4x4x___ PT (or 6x6) | Posts within frame, 5 for an initial landing, 4 if 5'x5' is a 90 degree turn, (2 additional posts will be in the frame but those will double with posts ordered with sections of ramp) |
| 4      | 2x6x10 PT           | Frame and common joists  |
| 2      | 2x4x8 PT            | Blocking, temporary support, bracing, miscellaneous, etc.  |
| 6      | 10' Deck Boards     | Walking surface over joists  |

#### Picket Handrails for 5'x5' Landing/Turn

|    |                 |                                       |
|----|-----------------|---------------------------------------|
| 3  | 2x4x10 PT       | Top/bottom rails and cap around frame |
| 30 | Pre-cut pickets | For rails around landing              |

#### Barn Rails for 5'x5' Landing/Turn

|   |           |                                       |
|---|-----------|---------------------------------------|
| 3 | 2x6x10 PT | Top, middle, and bottom rails/bumpers |
| 2 | 2x4x10 PT | Cap for rails around landing          |

#### 5'x8' Landing

|    |                     |   |
|----|---------------------|---|
| 4  | 4x4x___ PT (or 6x6) | Posts within frame (2 additional posts will be in the frame but those will double with posts ordered with sections of ramp) |
| 4  | 2x6x10 PT           | Short sides of frame and common joists  |
| 2  | 2x6x8 PT            | Long sides of frame/band joists   |
| 12 | 8' Deck Boards      | Walking surface over joists   |

#### Picket Handrails for 5'x8' Landing

|    |                 |  |
|----|-----------------|--|
| 3  | 2x4x10 PT       | Top/bottom rail, and cap on short sides of landing |
| 3  | 2x4x8 PT        | Top/bottom rail, and cap on long side of landing   |
| 45 | Pre-cut pickets | For rails around landing                           |

#### Barn Rails for 5'x8' Landings

|   |           |   |
|---|-----------|---|
| 3 | 2x6x10 PT | Top, middle, bottom rails/bumpers on short sides of landing |
| 1 | 2x4x10 PT | Cap for rails on short sides of landing                     |
| 3 | 2x6x8 PT  | Top, middle, bottom rails/bumpers on long sides of landing  |
| 1 | 2x4x8 PT  | Cap for rails on long side of landing                       |

### **5' Intermediate Landing**

|   |                     |   |
|---|---------------------|---|
| 2 | 4x4x___ PT (Or 6x6) | Posts within frame (2 additional posts will be in the frame but those will double with posts ordered with sections of ramp) |
| 2 | 2x6x10 PT           | Runners/joists  |
| 4 | 12' Deck Boards     | Or (6) 8' Deck Boards, walking surface over joists  |

### **Picket Handrails for 5' Intermediate Landing**

|    |                 |                                       |
|----|-----------------|---------------------------------------|
| 1  | 2x6x10 PT       | Top rail on landing                   |
| 2  | 2x4x10 PT       | Bottom bumper, cap over pickets/posts |
| 24 | Pre-cut pickets | Rails on both sides of landing        |

### **Barn Rails for 5' Intermediate Landing**

|   |           |  |
|---|-----------|--|
| 3 | 2x6x10 PT | Top, middle, bottom rail/bumper on both sides of landing |
|---|-----------|--|

### **Each 7'6" Section of Ramp**

|   |                 |   |
|---|-----------------|---|
| 2 | 4x4x___ PT      | Posts within sections of ramp                       |
| 4 | 2x6x8 PT        | Runners and ledger boards                           |
| 6 | 12' Deck Boards | Or (9) 8' Deck Boards, walking surface over runners |

### **Picket Handrails for each 7'6" Section of Ramp**

|    |                 |  |
|----|-----------------|--|
| 2  | 2x6x8 PT        | Top rail                                 |
| 4  | 2x4x8 PT        | Bottom bumper and cap over pickets/posts |
| 36 | Pre-cut pickets | Rails on both sides of ramp section      |

### **Barn Rails for each 7'6" Sections of Ramp**

|   |          |   |
|---|----------|---|
| 6 | 2x6x8 PT | Top, middle, bottom rails/bumpers on both sides of ramp |
|---|----------|---|

### **Other Materials/Fasteners:**

|     |                              |   |
|-----|------------------------------|---|
| ___ | 4" solid concrete cap blocks | Half a block for each post/hole (Or sackrete for each hole)                                       |
| ___ | Ledger Loks                  | 30 per each 5x5, 25 per each 5x8, 16 per 5' landing, 16 per each section of ramp                  |
| ___ | 2x6 Joist Hangers            | 6 per each 5x5, 10 per each 5x8, 2 per each 5' landing, 3 for each intersection of a landing/ramp |
|     | Joist Hanger Nails           |   |
|     | 2 ½" Deck Screws             | To attach deck boards and pickets   |



## **Recommended Ramp Tools**

### **Safety:**

Glasses  
Gloves  
Ear Plugs

### **Digging Tools:**

Post Hole Diggers  
Shovels  
Digging Bars or Sledge Hammer to break blocks

### **General Tools:**

Basic Hand Tools (Tape measures, hammer, pencils, speed square, etc)  
Saw Horses  
Extension Cords/Splitters  
Framing Square - for squaring layout line  
4' Level  
Post Level  
String/String Level  
Spray/Marking Paint  
Stakes - for tying off layout string

### **Power Tools:**

Drills/Impact Drivers  
→ (2-3) 1/8" Drill bits - to pre-drill handrails and pickets  
→ (3-4) T-25 drivers for deck screws  
→ 5/16 Hex bits or T-40 - coordinating to head of ledger loks  
Miter Saw  
Jig Saw - for notching around posts  
→ Wood Bladed  
Circular Saw - cut posts to handrail height  
Reciprocating Saw  
→ Wood Blade



# Mobile Homes

Mobile homes are manufactured buildings that come out of a factory ready to live in (heat systems/plumbing/and electric included). Mobile homes are designed to be moved to a site, placed on piers or a continuous foundation, and hooked up to service facilities. Initially, mobile homes were not intended for long term/permanent use. Prior to 1978 there was little regulation on mobile home structure.

1. Truss
2. J-Rail
3. Top Starter Panel
4. Metal Siding
5. Window
6. Exterior Door
7. Bottom Starter Panel
8. Wall Sheathing
9. Carpet
10. Carpet Pad
11. HVAC
12. Furnace Base
13. Moving Gear
14. Bottom Plate
15. Gusset
16. Water Supply Lines
17. Drain/Sewer Line
18. Fiberglass Insulation
19. Vapor Barrier
20. I-Beam
21. Outrigger
22. A-Frame
23. Hitch and Jack
24. Front Cross Member
25. Floor Joist
26. Stringer/Bracing
27. Vapor Barrier

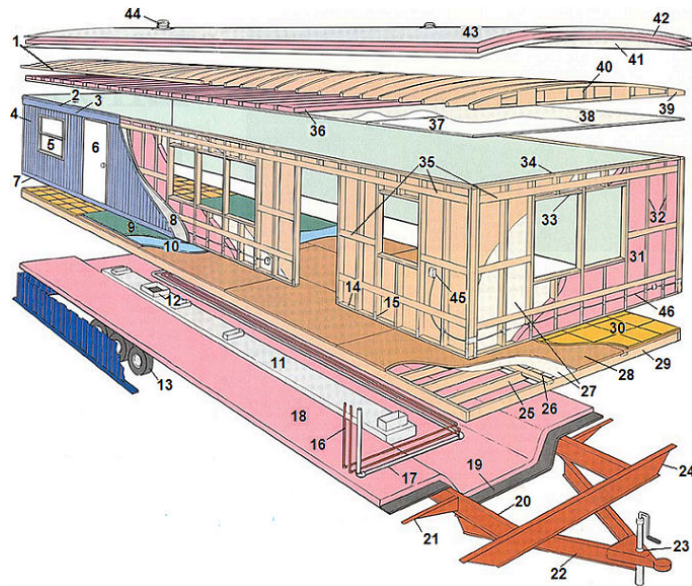

28. Floor Underlayment
29. Bottom Sill
30. Vinyl Floor Covering
31. Fiberglass Insulation
32. Studs
33. Header
34. Top Plate
35. Belt Rails
36. Second Layer of Insulation
37. Ceiling Panels

38. Second Roof Vapor Barrier
39. Truss Rafter
40. Tie Rail (Cross Rafter)
41. First Roof Vapor Barrier
42. First Layer of Fiberglass Roof Insulation
43. Galvanized Roof Steel
44. Furnace Roof Stack
45. Electrical Outlet Box
46. Electrical Wires

**Foundations** (See Diagram 2 and 3)

- I-beams run the full length of the mobile home and are the main support for the mobile home
  - I-beams should be supported every 8' with a pier
    - Piers are most likely concrete blocks
    - If any piers are compromised or missing, sonotubes should be installed (See pages 25-27 for information on sonotube installation)

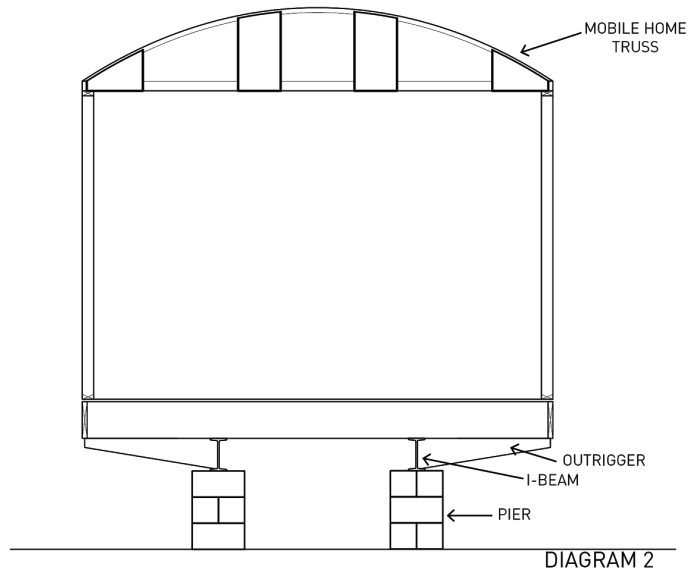

- Outriggers: come off the I-beams perpendicularly and support the rim joist and wall
  - If outriggers are missing or damaged, the rim joist/wall can be supported by installing a 4x4 post under the rim joist
    - See instructions for post installation on pages 19-21, install as a post would be installed under a girder

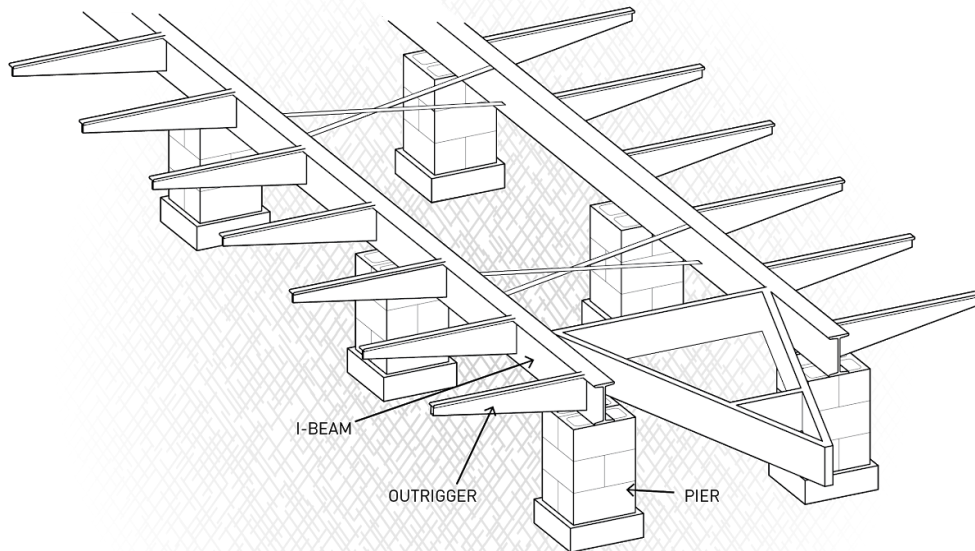

DIAGRAM 3

## Floors

- Structure:
  - Typically, mobile home floor joists will be 2x6s running perpendicular to the I-beams
  - Joists could also be 2x4s
  - Joists could run parallel to the I-beams
  - Check underneath mobile home to look at structure before opening up floors
- Floor framing sits directly on I-beams (See Diagram 2)
- If band joist repair is needed, wall/roof should be temporarily supported (See page 37)
- Subflooring is most often particle board
  - Particle board does not hold up to moisture and disintegrates quickly
  - If coming down to subfloor for repairs it is good practice to replace all particle board with  $\frac{3}{4}$ " OSB
  - Subfloor repair found on page 42

## Walls

- Walls are likely not a full 2x4
  - 2x2s or 2x3s are common
  - If repairs are to be made to walls, 2x4 will likely have to be ripped down to the correct width
  - Some suppliers do sell 2x2/2x3
- Exterior walls of the mobile home carry the weight of the roof trusses
- Mobile home siding
  - The metal siding of a mobile home provides lateral support and should not be removed unless alternate lateral support will be installed
  - Alternate lateral support methods could be sheathing or lateral 1x4s installed every 16" on center

## Roofs

- Mobile home roof structure consists of trusses that sit on the exterior walls
  - Trusses are made of small lumber (typically 2x2 or smaller)
  - Trusses are not intended to carry much weight and are easily broken
  - If work must be done on a mobile home roof, OSB should be laid down on the roof (crossing at least 3 trusses) to distribute the weight of a person
- Thin metal roofing is screwed into the top of the trusses, there is no solid decking to the roof
- Roofing options for mobile home roofs
  - For pitched roofs, SBS roof covering can be used (See page 114)

## Truss Repair

- Truss repair will be done from inside the home, ceiling drywall will likely be damaged and need to be removed if truss repair is needed
- For rounded mobile home roofs, add a block underneath the broken place in the truss (See Diagram 4)
  - The block used should not be wider than the truss
  - Extend the block 1' past the crack on each side
  - Screws should go into but not through the top piece of the truss
  - OSB plates should be cut that cover the crack and the reinforcement block, down to the bottom member of the truss
    - OSB is represented by the dashed line in Diagram 4A
    - OSB should be added to both sides

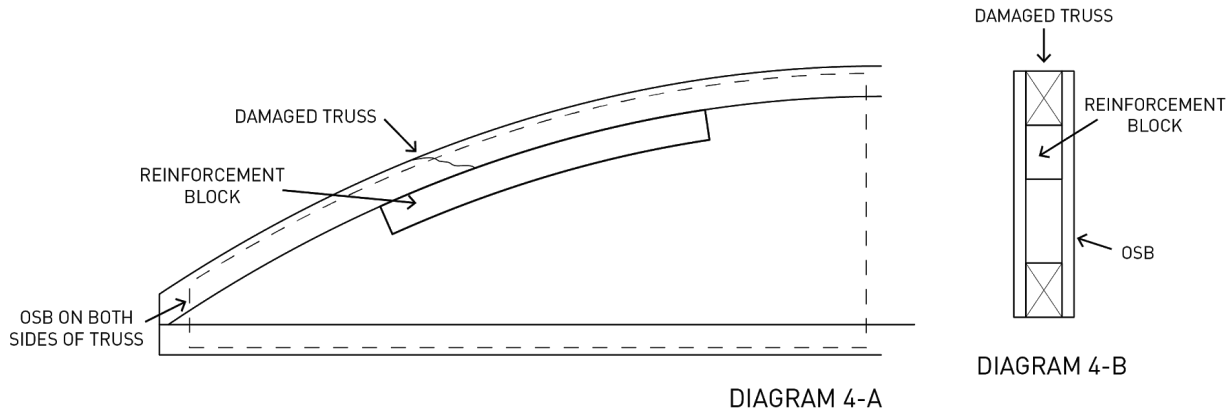

- For flat or gable shaped mobile home roofs, scabs should be added to either side of the cracked truss (See Diagram 5)
  - Scab should extend 2' past the damaged area on both sides
  - A scab should be added on both sides of the truss if possible

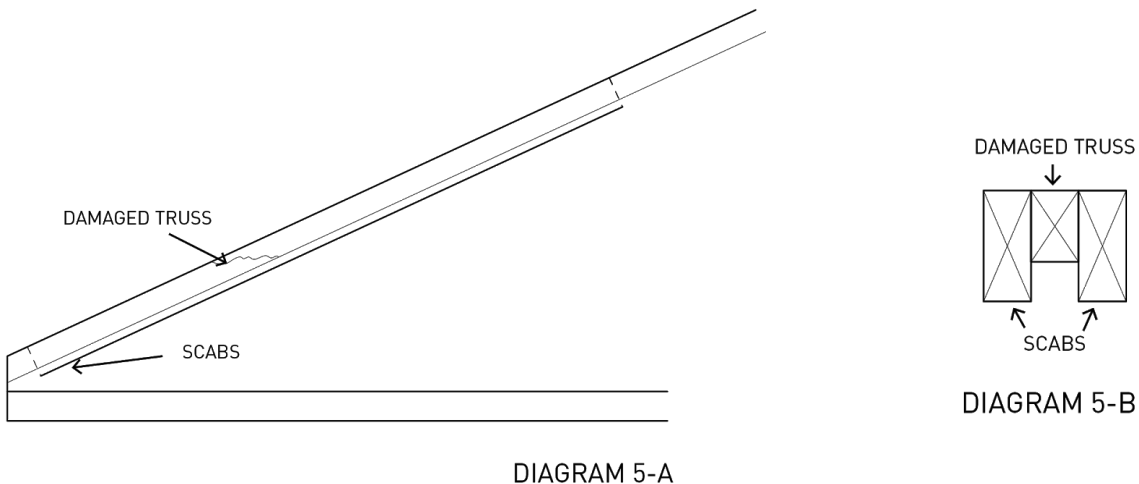

### **Roof Repair** (If there is a penetration in the metal skin of a mobile home roof)

- Locate leak and clean area with a plastic putty knife (removing chunks of roof coating)
- Cut a piece of metal flashing that will extend past the damaged area to the next truss on either side
- Run butyl tape or a bead of silicone caulk under the edge of the flashing
- Attach into the truss with roofing nails
- Run a strip of SBS that covers the patch and runs over the peak of the mobile home
  - Roll the SBS with a roller to help it adhere
- This should only be done in situations where there is one damaged area and the rest of the roof is in good condition, otherwise a full roof covering replacement should be considered

### **Common Mobile Home Issues**

- Rotten floor/wall under ac unit
  - This often happens because AC unit leaks and the window opening left by the AC unit is not sealed properly
  - Make sure that the AC unit slopes away from the home to drain properly
  - Unit can be supported by bracing on the outside if needed
  - Seal the open space left from the AC unit so that water cannot come in
    - Lauan cut to size can be used, paint outside to make waterproof
- Saggy vapor barrier underneath the home
  - If the vapor barrier under the home is sagging, the insulation may be sitting on top of that and not in contact with the floor, therefore not insulating
  - If the vapor barrier is sagging in one location, it could be an indication of a plumbing leak
- Water running into windows and exterior doors
  - Windows and doors can be caulked
  - Overhang can be installed with SBS roofing or shed roof system to keep water from running down the walls onto window/door frames







# Hug Systems

**Why Hug System?** The Hug System allows access to floor/wall repair from the outside of the home, adds significant insulation to the entire home, and provides both new roof covering and new siding/underpinning. The system reduces energy cost for the homeowner and creates a new, thorough building envelope.

## Safety

- Be aware of wires/plumbing that may run through walls that you are fastening into
- Be aware of and avoid any underground utilities that may interfere with framing around the bottom of the home
- Use ladder safety from page 9
- See project specific sections for additional safety information (siding, SBS, etc.)
- Watch out for any bees/critters under home
- Look for any plumbing leaks under home before closing in crawl space

## Hug System Project Planning

- What kind of obstacles will you have to work around? (porch roofs, cables, etc.)
- Locate where wires are likely to be and use shorter fasteners in these areas. (At the level of outlets, where switches are located)
- Is there adequate time to complete this entire project?
- How will the top of the hug system be terminated? Under the existing eave or will an overhang have to be added?
- Is the hug system going over lap siding? Vertical nailers may be required.
- What color siding does the homeowner want?

## Measurements Needed

- Dimensions of home
- Height from ground to eave at each corner or height from foundation to eave
- Number of windows/doors - how much J-channel will be needed to go around each one?

## **Quality Control**

- Are nails for foam and siding going into studs?
- Is foam terminating into J-channel around doors/windows?
- Is there venting to the crawlspace?
- Is there an access door to the crawlspace?
- Are seams of the foam being taped?
- Is the siding level at the starting point?

- *See project specific sections for additional quality control/common mistake information*

## **Common Mistakes**

- Nails missing studs, just fastening into metal siding
- Foam just cut around windows/doors
- Venting left out completely

## **After Work is Complete Quality Control Check**

- Is the transition from siding to roof smooth?
- Is J-channel around windows/door caulked?
- Is there venting to the crawlspace?
- See project specific sections for additional After Work Quality Control checkpoints

# **Hug System Instructions for Mobile Homes**

## **Order of Operations:**

(See Diagrams 6 and 7)

- Any needed band joist/wall repair (page 37)
- Framing around base of mobile home (page 287)
- Trim windows/doors with J-channel (to receive foam) (pages 142)
- Build out overhang around roof (page 289 and page 117)
- Install foam on walls (291)
  - Can start installing foam on roof at this time as well (page 293)
- Install flashing along bottom (page 292)
- Install vinyl trim and siding (after foam on walls) (page 133)
- Install metal fascia (page 140)
- Install SBS roofing, attach with termination bar (page 114)

## Framing Around Base of Mobile Home:

Hug systems on mobile homes combine the underpinning and siding into one unit. To do this, framing (much like underpinning framing) is needed to attach the foam, flashing, and siding to.

- **Install Bottom Plate** (See Diagram 9)
  - Prep bottom plates by drilling  $\frac{1}{2}$ " holes in base plates every 6' or at each end of pieces shorter than 6'
  - When planning for rebar placement, be cautious of any underground utilities and allow a 3' clearance from them with the rebar
  - Use a plumb bob from the outside surface of existing siding to determine where the bottom plate will rest
  - When outside edge of bottom plate is flush with outside edge, hold bottom plate in place and pound 12" pieces of rebar in each hole drilled (heavier hammers will be better for this)

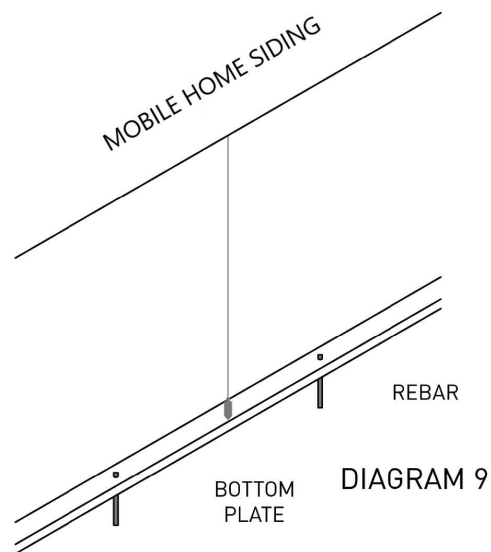

## Install Vertical Framing Members and Locating Existing Wall Studs (See Diagram 10)

- Vertical framing member will be 2x4 material
- **Vertical members should be installed directly below wall studs an no more than 24" apart.**
  - Location of wall studs can be determined pushing in on mobile home skin or driving short test screws to locate studs.
- Plan for access doors during vertical member installation, it should be near plumbing shutoff. It can be built as described in the underpinning sections using painted plywood as the door and vertical framing members as the jambs.
- Measure between the bottom of the band/rim joist and bottom plate for each individual member to get the length for each vertical member
- Turn vertical members so that the wide side is facing out. The primary function of these members is to receive siding. Turning them wide side out makes them easier to attach to.
- Fasten vertical members at the band/rim joist and then use level to make sure all members are plumb before fastening to bottom plate
  - Toe-screw members into place with 3" screws
- At each side of each corner, install vertical members 2 ½" from the very corner

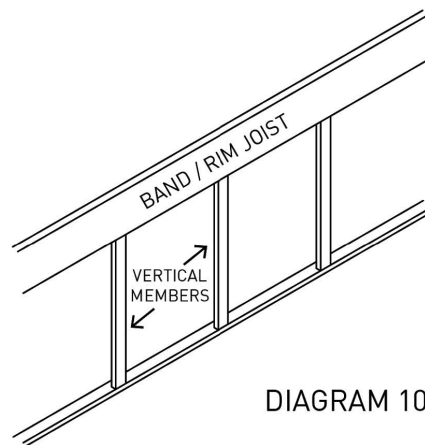

DIAGRAM 10

**Build Out Overhang** (Only if foam/SBS roof covering are being installed)

- The purpose of the built out overhang is to prevent water from running down the wall and over windows
  - This also separates the wall and roof system so that they can be worked on at the same time
- Remove gutters if necessary
  - If these are rigid and hard to remove, they can be cut flush with the wall using a reciprocating saw with a metal cutting blade
- Install a treated 2x4 around the top edge of the wall
  - Before installing, cut the top of the 2x4 at an angle that will match the line of the roof using a table saw
  - Fasten with 3 1/2" to 4" screws into the top plate of the wall or ends of trusses
  - Fasten every 12"-18"
- Install a treated 1x6 on the outside of the 2x4 (See Diagram 7A)
  - Like the 2x4, cut the top of the board at an angle that will match the roof
  - Install with 2" screws in to the 2x4
  - Fasten every 12"-18" with one screw over the other
- Short ends of the mobile home: (see page 117 and Diagram 7A)
  - If the roof is flat, continue the 2x4 and 1x6 all the way around the roof
  - If the roof is sloped with a defined ridge, install the 2x4 and 1x6 at those angles
  - If the roof is rounded, cut 2x4 and 1x6 at multiple angles to match as closely as possible to the profile of the roof (See page 117, Diagram 26)
  - If there is a built in overhang on the short ends of the mobile home, the 2x4/1x6 do not need to be installed on that side (page 114, See Diagram 27)
- Install metal fascia covering over the 1x6 (See page 117, Diagram 25)
  - Attach with white aluminum trim nails every 18"-24" one over the other
  - On eaves, start at one side and work towards the other, overlapping pieces 4"
  - Make tabs for corners to keep water out

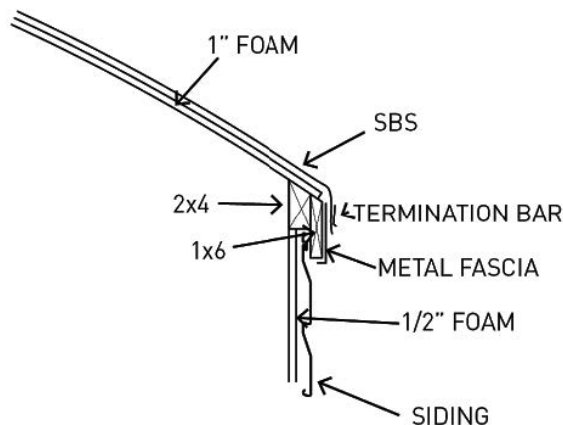
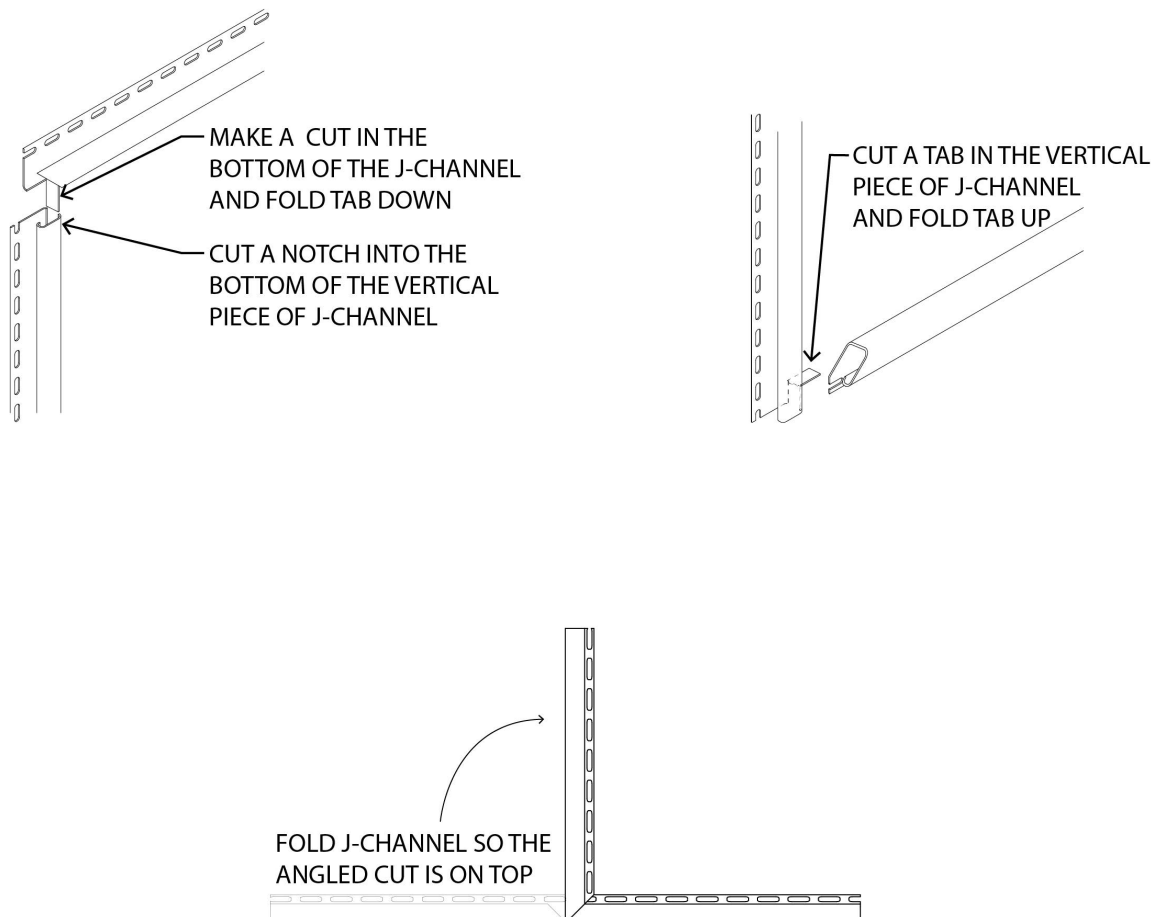

DIAGRAM 7-A

## J-Channel Around Doors and Windows to Receive Foam

Windows and doors are the most vulnerable component of the hug system. Increasing the depth of siding often creates a ledge for water to enter below the window. The solution for this depends on the window, if there is window trim, if it's a window that is boarded up, etc. If replacement windows are allowed by the budget, replacing them with vinyl windows with a siding flange can alleviate this problem. If replacement windows are not accessible, take special care with the J-Channel around the windows especially. Any seams or gaps must be small enough to receive sealant.

- Windows/doors/other obstructions should be trimmed with J-channel that will hold the edges of the foam that will be installed
- Some counties may be able to source 1 1/2" J-channel. This can receive both the foam and siding.
- The false miter method is a good way to make the J-Channel weather-tight
- Place J-channel around mobile home doors and windows so that they can still be removed in the future. (Place J-Channel adjacent to flange of window)
- See more detailed instructions for J-Channel installation on Page 142.



## Foam Board Installation on Walls (See Diagrams 6 and 7)

- ½" foam should be used on the walls
- Sheets of foam will run horizontally
- The bottom of the first sheet should fall on the bottom plate
  - If needed, cut the bottom of the piece at an angle so that the top on the first row stays parallel to the mobile home
- Cut foam by scoring with a utility knife, then bend the two edges away from the cut and it should split at the score mark
- Sheets of foam should be attached with lathe screws (1 ½" - 3")
  - Make sure nails are fastening into studs
  - **IN AREAS WHERE THERE MAY BE WIRES BEHIND WALL, USE SHORT SCREWS**
- Transfer the locations of studs onto the foam board
  - These lines will be used to help locate studs for higher courses of foam and while installing siding
- Continue installing foam board in rows until a full piece will no longer fit
- Top course of foam
  - Run the foam up to the bottom of the 2x4 overhang that was installed around the edge of the roof
- Seal all seams of foam with housewrap tape

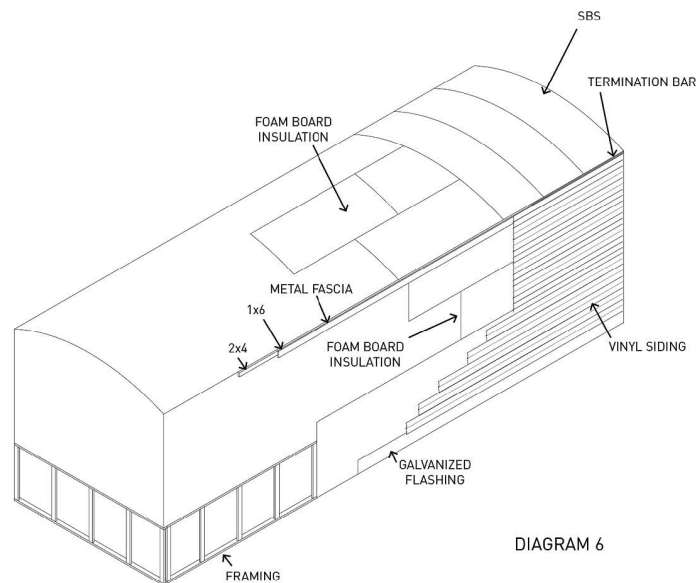
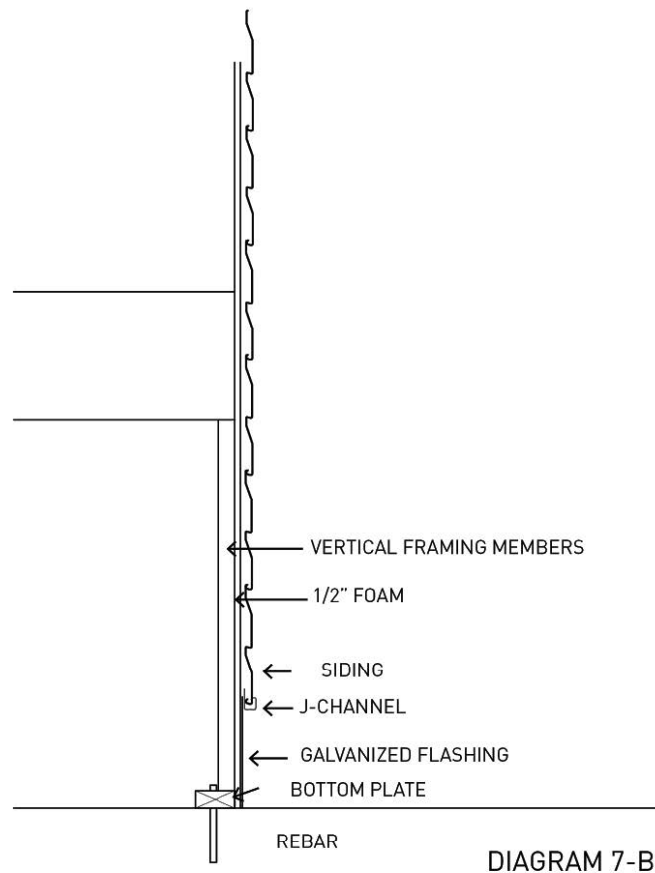

DIAGRAM 6

### Install flashing (See Diagram 7B)

- 8-12" galvanized flashing is install along the bottom of the wall over top of the foam. It should be installed with roofing nails every 12" on the top on bottom and should overlap or wrap around corners.
- It can follow grade and does not have to be level, but the bottom of flashing should contact the ground
- It will likely have to be cut to manipulate it to go up and then down hill. Overlap seems a minimum of 6"





## Installing Foam Board on Roof (With SBS System) (See Diagram 6)

- 1" to 2" **RIGID FOAM** should be used on the roof
  - Foil faced foam should not be used on roof
  - Extruded polystyrene foam is rigid, expanded polystyrene is not rigid
- Sheets of foam will run perpendicular to the trusses of the roof
- Sheets should start at the edge of the built out overhang
- Attach foam with 2" wafer head screws into the mobile home trusses
  - some success has been had using Loctite Adhesive rather than screws to prevent holes in mobile home roof skin
- Seal all seams of foam with housewrap tape

## Install SBS Roofing (if applicable)

### Cut Pieces

- Measure the needed length, pieces will run down the wall 3"-4"
- Pieces can be cut a little long and then trimmed after installation
- Pieces should be cut on the ground using a hook blade
- Pieces can be rolled up and easily carried up to the roof

### Install Pieces (See Diagram 28)

- Position the first piece with the sticky tab facing the field
- Allow 6"-8" to overhang the short side of the mobile home
- Make sure that there is even overhang on each end

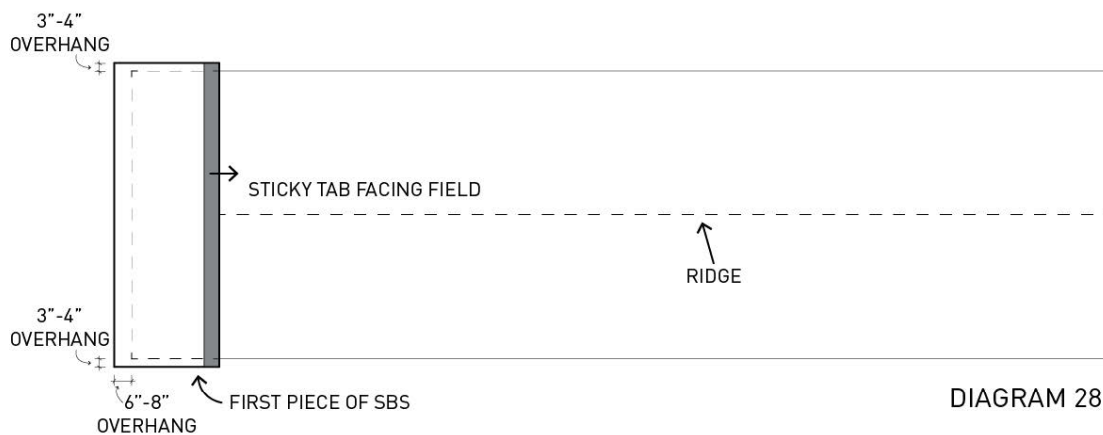

- Stick the first piece down (See Diagram 29)
  - Hold the piece in place on one side of the roof
  - Fold the other half of the piece back, exposing the backing
  - Remove the backing on this half, while still holding the other half in place
  - Let the piece down, working from the peak of the roof towards the eave of the mobile home
  - Then, fold the other half back, remove the backing, and let it down to the roof, working from the peak to the eave
- Using a roller, go over the entire piece applying pressure to help the SBS adhere to the roof
  - Work from the overlap side towards the field

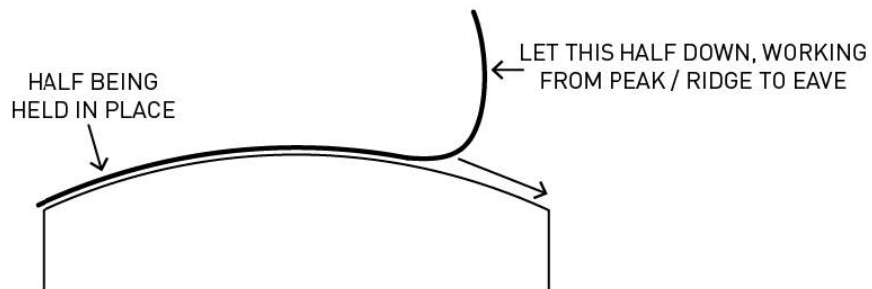
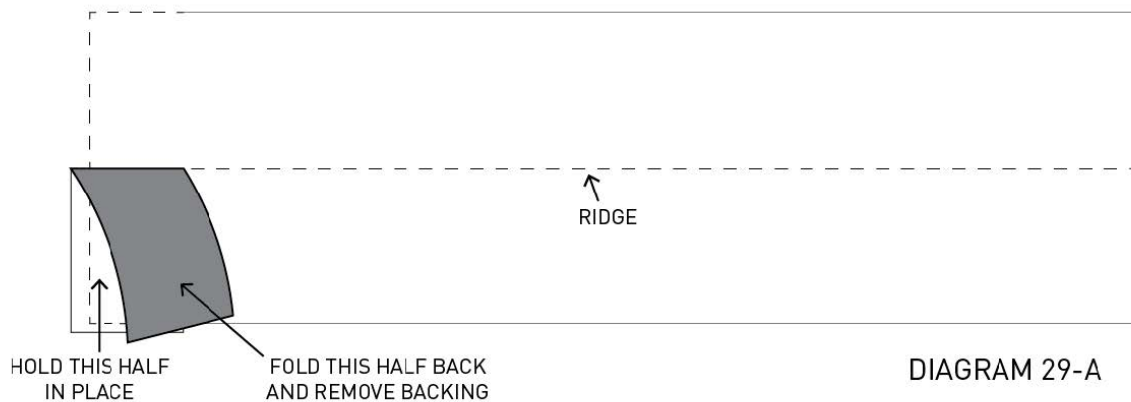

- Get the next piece into position
  - The next piece should cover the sticky tab of the previous piece (See Diagram 30)
  - Do not remove the plastic from the overlap tab on the first piece yet
  - Repeat the same process of holding half of the piece, folding back the other half, and removing the backing (See Diagram 29)
- At this point, also remove the plastic from the overlap tab on this half of the roof.
  - Let the piece down, working from the peak of the roof towards the eave of the mobile home
  - Repeat this process on the other side of the roof
- Repeat this process down the length of the roof
- Roll all pieces with roller applying pressure to help pieces adhere

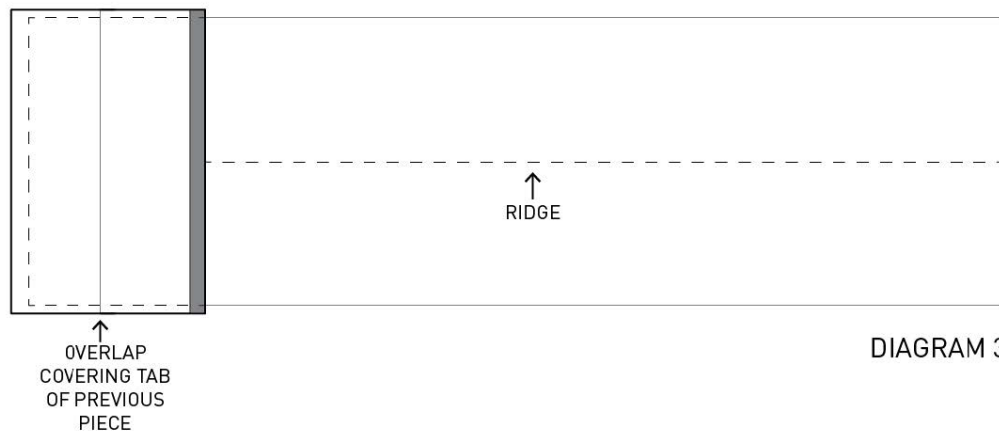

## Vent Pipes

- Cut a hole in the SBS so that it can slide down over the existing vent pipe. It should fit tightly around the vent pipe.
  - apply a generous bead of roofing sealant at the bottom of the vent pipe
  - dry fit the boot over the pipe, then apply roofing sealant where the boot will contact the SBS
  - install boot cover around perimeter every 2" with neoprene screws
- For more details on working around vent pipes see page 122.

## Install Termination Bar

- Termination bar is a critical component of the hug system. It is what mechanically fastens the SBS to the home
  - Fastened over SBS 3"-4" down from the top of the fascia.
  - Ideally at the bottom of the SBS. **If SBS is uneven it can be trimmed right below the termination bar at this time. A hook blade is great for this.**
  - A neoprene screw should be placed in every hole of the termination bar
  - Be careful not to overdrive screws and strip the wood
  - On short ends of rounded roof mobile homes cut smaller sections to match profile (See Diagram 37C)
  - More details on termination bar can be found in the SBS section on page 123.

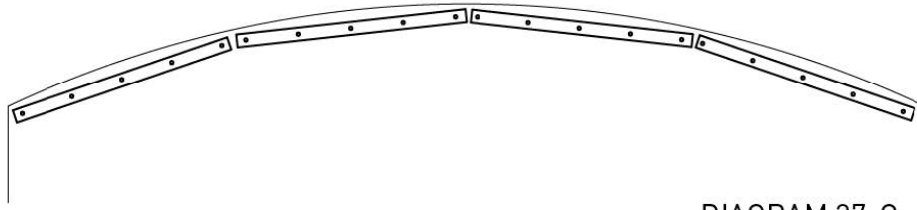

DIAGRAM 37-C

### **Install Vinyl Siding** (See page 133 for more details)

- Install Vinyl Trim Pieces
  - Corner pieces will but up to the overhang that was built and 3" below the top of the flashing
  - Make sure corner is even on both sides and attach with 1 1/2" lathe screws
- Install J-channel or starter strip along bottom of wall
  - Measure down from the top of the wall to find a consistent height on both sides. Use a line level and a chalk line to indicate where the J-channel or starter will be installed.
    - It is a little easier to measure up the height of the J-channel or starter strip before chalking the line. That way J-channel or starter strip is installed below the line rather than on top of it.
  - J-Channel should be tucked into corner posts
- Install a second course of J-Channel around doors and windows (if applicable)
  - Special care should be made that corners are tight and gaps between courses of J-channel are minimal
  - High grade UV rated exterior caulk should be used to fill any of these gaps.
- Install siding
  - Siding is installed as described in the siding section of the manual with only minor differences.
  - Instead of roofing nails, we have had more success using lathe screws on mobile homes. Special care should be taken that screws are not completely tight so that the siding has the ability to expand and contract. A good rule of thumb is a dime should fit between the screw head and siding.
  - **Beware of likely locations of electrical wires within the walls. Typically there are several wires between floor level and roughly 24" up from the floor. Using shorter screws (1") in this zone will minimize the chance of driving a screw into a wire.**
  - The built out overhang will act as the J-channel at the top of the siding. Attach top course with fascia nails through the weep holes of siding.

### **Finishing**

- Trim SBS extending below termination bar
- Caulk J-channel seam around windows/doors

# Hug System Instructions for overlaying lap siding:

The hug system can also be installed on stick built homes that are in need of additional insulation and thermal barrier. Some lap siding has laps that are minor enough the foam itself is enough to flatten the wall appropriately to install vinyl siding. Sometimes this is not the case and vertical nailers are needed to to install the vinyl siding in a flat, consistent plane.

- Wooden lap siding has deep laps that may require these vertical nailers
- For homes that studs are difficult or seemingly impossible to find vertical nailers may be used
- Occasionally we install siding on a block house. Vertical nailers can be used in this situation

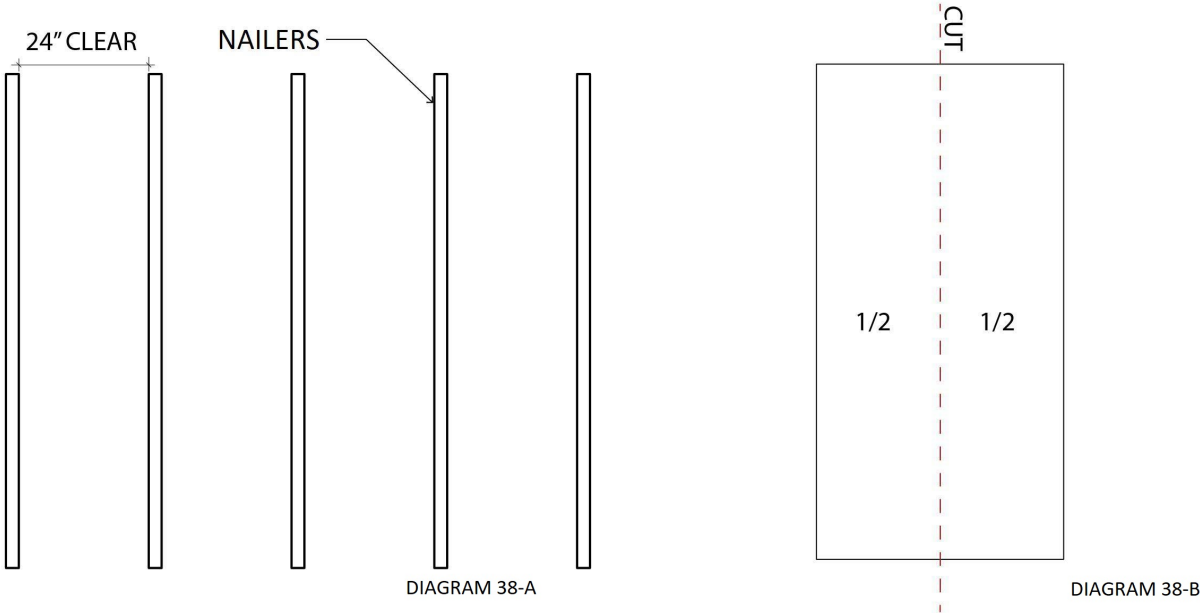

- Nailers should be installed 24" apart so that half a piece of 48" wide foam fits between the nailers (See Diagram 38)
- Install with two 2 1/2"deck screws every 16" up the wall. (Use lathe screws if attaching to metal and tapcons if attaching to concrete)
- Frame the outside of doors and windows with nailers.
- Place cut pieces of blue foam in between nailers and tape both sides to nailers using housewrap tape.
- Install corner posts
- Install J-Channel or starter strip across bottom of nailers, making sure that the foam and nailers will be concealed. Measuring down from the top and using a chalk line with a line level can help to get ensure the j-channel or starter strip is level.
- J-channel is installed around windows and doors and attached to nailers.. Take care to install tightly around frame and be sure to caulk any gaps with UV resistant caulk.
- Install J-Channel at top of wall for the top course of siding.
- Install siding as described in Siding section. Roofing nails or lathe screws may be used. Take care that vinyl has room to expand and contract. (See page 133)

## Hug System Material List

| <u>Quantity</u>                         | <u>Item</u>  | <u>Purpose/Notes</u>  |
|---|--|---|
| <b><u>Framing:</u></b>                  |  |   |
| ___                                     | 2x4x___ PT<br>(2x4 can come in any length)                       | Bottom plate:<br><i>Perimeter of home (in feet)/length of lumber = # of pieces</i><br>Vertical members for each corner, other vertical/horizontal members (as applicable), access door material   |
| ___                                     | 1/2" (#4) Rebar  | For anchoring bottom plate to the ground<br>1' of rebar is need for every 6' of base plate<br>→ <i>Perimeter (in feet)/6' = # of pieces of rebar</i><br>→ <i># rebar needed/10' (typical selling length of rebar) = # of 10 pieces</i><br>Add a few extra pieces of rebar |
| ___                                     | 3" Screws<br>*nailers may be required                            | Used to attach top plate and vertical framing<br>Used in some applications  |
| <b><u>Access Door Material:</u></b>     |  |   |
| ___                                     | 1/2" Plywood   | To cover the frame  |
| ___                                     | 1 1/2" Exterior Screws   | To fasten the plywood to door frame   |
| ___                                     | Exterior Primer/Paint  | To paint access door  |
|   | <i>Or get vinyl/j-channel or metal to cover access door with</i> |   |
|   | Exterior Hinges  |   |
|   | Latch for Access Door  |   |
| <b><u>Foam Insulation Material:</u></b> |  |   |
| ___                                     | 1/2" Foam Board  | For walls   |
| ___                                     | 1" to 2" Rigid Foam Board  | For roofs   |
|   | To calculate needed foam:  | <i>SF of walls to be insulated/32 (SF in one piece) = # of pieces needed</i>  |
| ___                                     | J-channel  | To catch edges of foam around doors/windows<br><i>Linear feet needed/12 (feet in one piece) = # of pieces needed</i>  |
|   | Housewrap Tape   | To seal seams of foam   |
|   | 1 1/2" lathe screws  | For attaching foam and j-channel  |
|   | Window/Door Caulk  | To caulk j-channel around windows/doors   |
|   | 12" Galvanized Flashing  | To install around base of home  |

See Vinyl Siding section for materials/recommended tools

For SBS Roof Systems, see SBS roofing section for materials/recommended tools (including material for the built out overhang)

## **Recommended Tools**

### **Safety:**

Gloves (Sturdy/leather for working with metal)

Glasses

Ear Plugs

### **Power Tools:**

Miter Saw

Drills/Impact Drivers

→ T-25 Drivers to match deck screws

→ Philips bits for lather screws

→ ½" Drill Bit to drill holes for rebar

Circular Saw

→ Wood Blade

→ Metal Cutting Blade for cutting rebar

(or) Angle Grinder - with metal cutting blade to cut rebar

### **Digging Tools:**

Shovel - to level out ground as needed and create positive drainage

### **General:**

Basic Hand Tools (Tape measures, hammers, pencils, speed square, etc)

Utility Knives - for cutting foam

Saw Horses

Extension Cords/Splitters

Caulk Gun

Tin Snips

Level

Heavy Hammer - to pound in rebar

Plumb Bob

Ladders







# Room Additions

**Why room additions?** Room additions can allow children's bedrooms to be separated by gender. Additionally, bathroom additions can be added if there are not adequate bathroom facilities or accessible bathroom facilities are needed.

## **ASP builds five standard sized room additions**

- 8'x12' Single Bedroom Addition
- 8'x24' Double Bedroom Addition
- 5'x5' Bathroom Addition
- 8'x20' Bedroom and Bathroom Addition
- 8'x10' Accessible Bathroom Addition

## **Safety**

- When opening up the wall, cut slowly in case there is a wire in the wall
- Be aware of underground utilities where footings will go
- Reference project specific sections for more safety information

## **Room Addition Project Planning**

- Check with inspector about needed permitting and inspections
- Identify subcontractors to work with (electricians for all room additions and plumbers for bathrooms/kitchen/laundry)
- Check the breaker box in the home, will it support the additional load?
- Where will the room attach to the existing home? (Consider the following)
  - Ease of roof transition
  - Proximity to septic/electric lines/etc.
  - Property lines
- Where will the door be cut to access the new room?
  - Cannot come out of an existing bedroom unless a hallway is built as well
- Where will water for concrete mixing come from?
- See project specific sections for additional project planning information

## **Measurements Needed**

- Height off the ground for the piers
- See Project specific sections for more information on measurements needed for material ordering

## **Quality Control**

- Holes for footings should be widened out at bottom
- Make sure all holes for footers are in the correct place before pouring concrete
- All concrete in each individual hole should be poured at one time
- Post connector should be inserted into the wet concrete
- Check outside wall height (minimum 84 ½")
- Check that window opening is 18" above floor
- Make sure that the transition from addition roof to existing roof is smooth
- Make sure roof venting is added
- Make sure adequate flashing is added between existing house and room addition walls
- Make sure flashing and a strip of SBS are installed before the 2x4/2x6 overhang
- See specific project sections for additional Quality Control/Common Mistakes checkpoints

## **Common Mistakes**

- Outside frame for floor system not used to mark holes, they are dug in the wrong place
- Concrete count not double checked before each hole, pour one partially full and then run out
- Walls built at height with full studs, not low enough to allow slope to roof
- If outside wall is too low, roof transitions may be rough
- Flashing forgotten and siding butted up to the existing wall, allowing water and air to move in easily
- 2x4 and 2x6 installed before flashing/SBS

## **After Work is Complete Quality Control Check**

- Is the room attached to the home well and watertight?
- Is the doorway from the existing home into the new room trimmed well?
- Is there a smoke detector installed in each new bedroom?
- See specific project sections for After Work Quality Control Checks

# Room Addition Instructions

## Order of Operations:

- Build Floor Frame pg. 305
- Determine Floor Height pg. 306
- Holes For Footers pg. 307
- Temporarily Set Floor Frame pg. 308
- Pour Footers pg. 309
- Install Piers pg. 310
- Install Common Joists pg. 311
- Instal Subfloor pg. 45
- Frame and Stand Walls pg. 65 and 312
- Install Rafters pg. 312
- Sheath Walls pg. 75 and 316
- Flashing (from existing home to new addition) pg. 317
- Build Out Overhang (on gable sides of roof) pg. 319
- Install Fascia Board pg. 319
- Deck Roof pg. 94 and 320
- Install Metal Fascia on Gable Sides Only pg. 320
- SBS Roof Covering pg. 124 and 320
- Housewrap pg. 136
- Cut Door Opening Into Home pg. 321
- Install Window(s) pg. 79
- Vinyl Soffit/Metal Fascia pg. 146
- Vinyl Siding pg. 151
- Subcontractor (electrician/plumber) come through at this point pg. 321
- Insulate pg. 157
- Underpinning pg. 209
- Set shower/tub (if applicable, see product instructions)
- Drywall (Install and Finish) pg. 167
- Install and Trim Interior Door pg. 84
- Prime/Paint pg. 181
- Install Finished Floor pg. 56
- Set Light Fixtures/heaters/toilet/vanity
- Trim (Baseboard and Windows) pg. 189

# Reference Diagrams

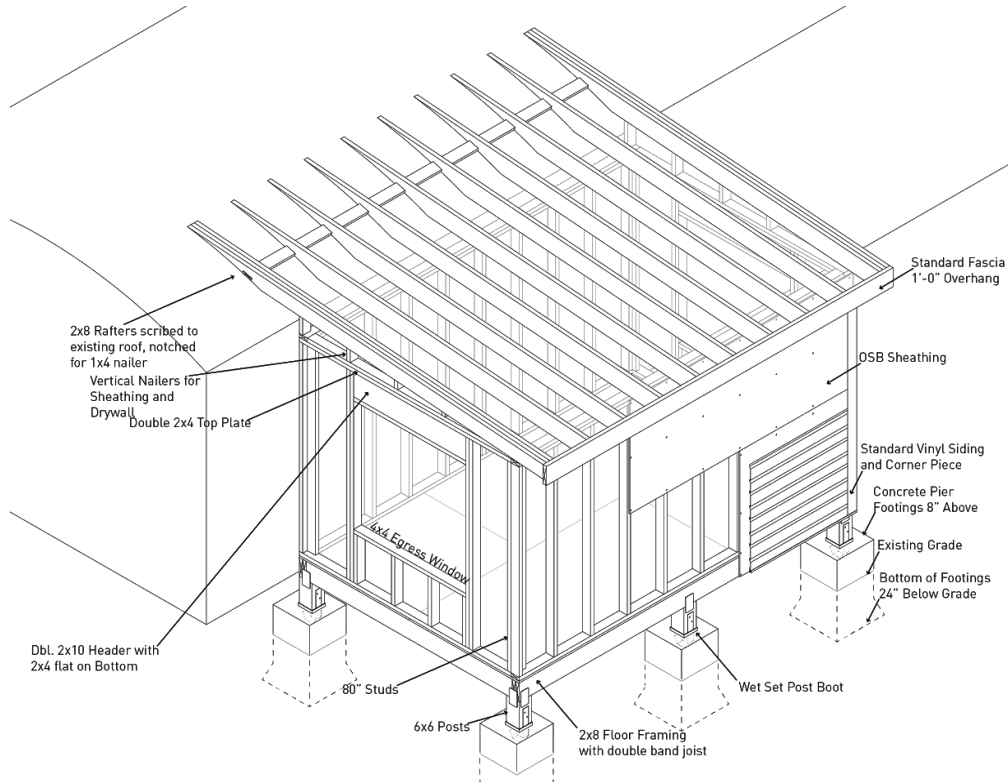
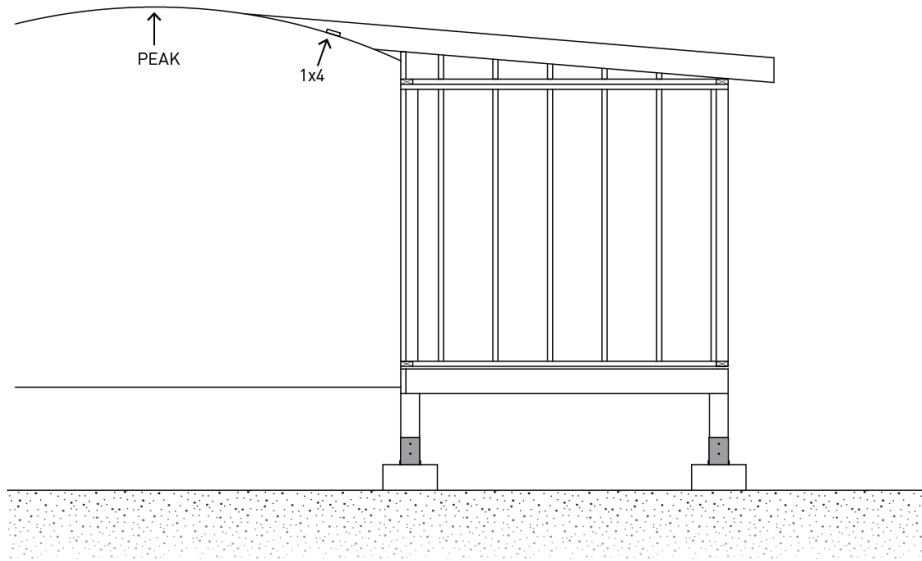

## Build Floor Frame

- The finished dimensions of the outside of the frame should equal the dimensions of the planned room addition
- Build the outside perimeter of the frame (See Diagram 1)
  - Double band joist
    - Cut pieces for the outside band joist 3" short of the finished length of the room addition
    - Cut pieces for the inside band joist 6" short of the finished length of the room addition
    - Use full lengths of lumber if possible, if necessary to use multiple pieces and stagger seams by 4'
  - Double rim joist
    - Cut pieces for the outside rim joist to the full width of the room addition
    - Cut pieces for the inside rim joist 3" short of the finished length of the room addition
  - Assemble the frame with 3" exterior screws, one over the other every 12"
    - Intersect corners as seen in Diagram 1 to create a frame with finished outside dimensions of the given room
  - *For example, if the room addition is 8' x 12' the length of pieces cut will be*
    - *Outside Band: 11'9"*
    - *Inside Band: 11'6"*
    - *Outside Rim: 8'*
    - *Inside Rim: 7'9"*

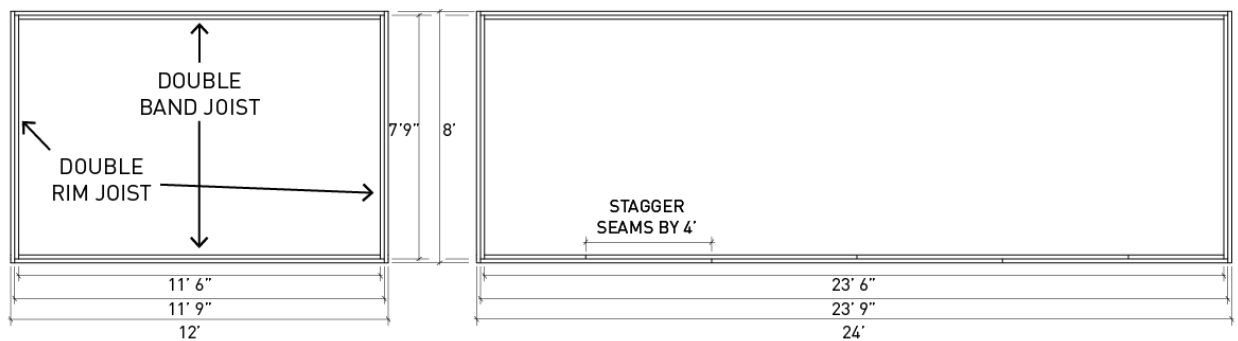

1-A

1-B

DIAGRAM 1

- Adjust the frame to square and add temporary bracing to help keep its shape
  - Use framing square to adjust the corners
  - Place the bracing so that it will not interfere with the frame being put in place against the home

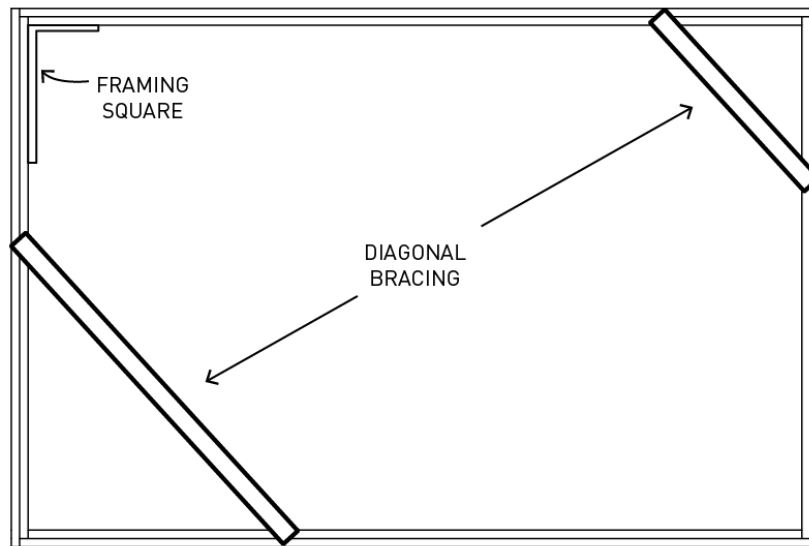

DIAGRAM 2

## Determining Floor Height

- The top of the new floor system should align with the top of the existing floor system
- If the addition is to a house, remove a section of siding to determine where the top of the existing floor system is
- If the addition is to a mobile home, cut a slit in the skin of the mobile home up from the bottom that allows you to see the top of the band joist
- Make sure this slit is cut or siding is removed in the **space that the new door will be cut** from the existing house to the new addition (cover with tape to water seal until room is in place)
- Make a mark on the outside of the siding/mobile home skin at the top of the floor joists
  - Transfer that line across the wall where the room addition will be using a level
  - This is the mark that will be used to line up the top of the addition's band joist against the home

## Holes for Footers

- Move the frame into its position (but sitting on the ground) and mark where the holes will be dug for the footers
  - Mark each corner
  - For any side over 8' there will also be intermediate piers
    - For 10' and 12' lengths there should be a pier in the middle of both long sides
    - For 20' lengths there should be two intermediate piers on each long side at 6'8" on center
    - For 24' lengths there should be two intermediate piers on each long side at 8' on center
- Dig holes at each mark (See Diagram 3)
  - Holes should be dug 16"x16"x24" deep
  - At the bottom of each hole, dig the bottom wider than the 16"x16" top

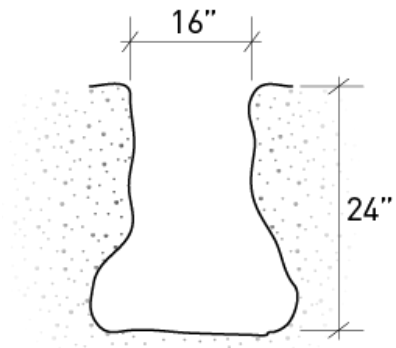

DIAGRAM 3

- Build boxes out of 2x8 material for each pier (See Diagram 4)
  - This will be temporary so it does not need to be pressure treated
  - Open space created by box should be 16"x16"
  - Place these over each hole, they will allow the concrete to extend above the ground when poured
  - Attach a 2x4 scrap to two sides of the box that extend over the opening of the hole to hold the box in place if needed
  - These boxes must be level so that concrete poured to the top will also be level
    - Adjust ground underneath them if needed to make them level

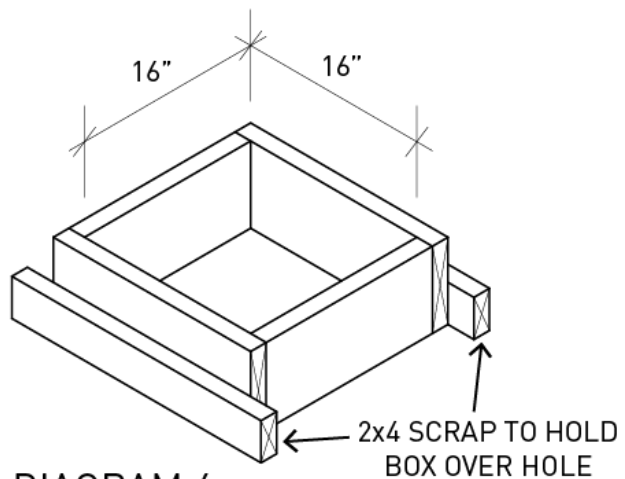

DIAGRAM 4

## **Temporarily Set Floor Frame** (See Diagram 5)

- Move frame into place over holes
- Align with mark for the top of band joist against the home
- Attach temporary 2x4 supports resting on cap blocks
  - Level and temporarily support the side against the home first
  - Then check level on the short sides and outside, and attach temporary supports across the front
  - Temporary supports should be roughly every 8' and attached with 3" screws
- The frame should be square itself and square to the house
- Check that all holes and boxes for footers are in place to receive posts that will sit directly under the floor frame
  - Adjust boxes/holes if needed

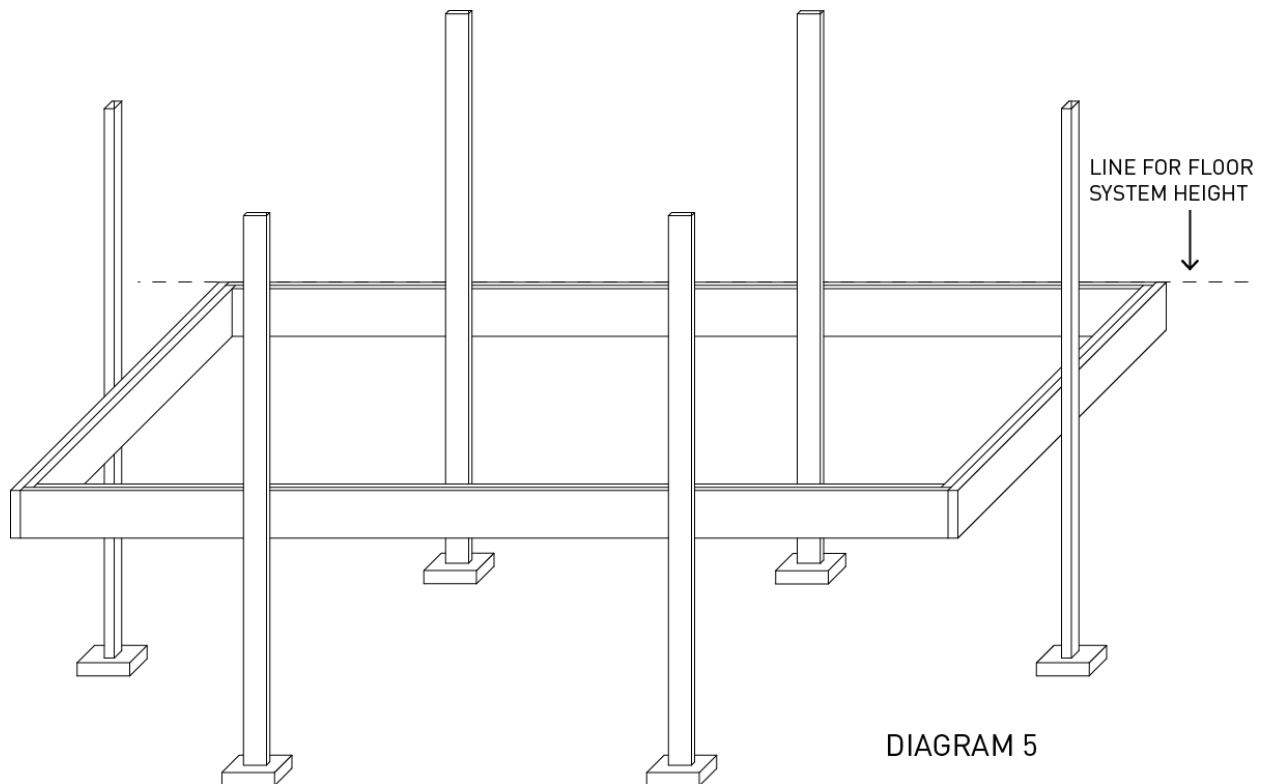

DIAGRAM 5



## Pour Footers

- It is important that all concrete in a hole is poured at one time so that the concrete dries as one unit
  - As you mix and pour for the first hole, count the bags used and make sure that there is enough for the remaining holes, do not start pouring for a footer that there is not enough concrete to complete
  - Make sure the bracket is present, it needs to be set in place while concrete is wet
- Mix concrete in a wheelbarrow or pan using a garden hoe
  - Follow the instructions on the concrete packaging for water to concrete ratio
- Fill hole and box to the top of the 2x8
  - Level off the top using a trowel
- Set bracket in concrete (while the concrete is still wet)
  - Use a plumb bob from the frame to determine where the bracket should go (See Diagram 6)
  - It is important that the bracket be in place so that the pier that is installed between the frame and the bracket will be plumb
- Allow the concrete to cure/dry overnight before installing the piers

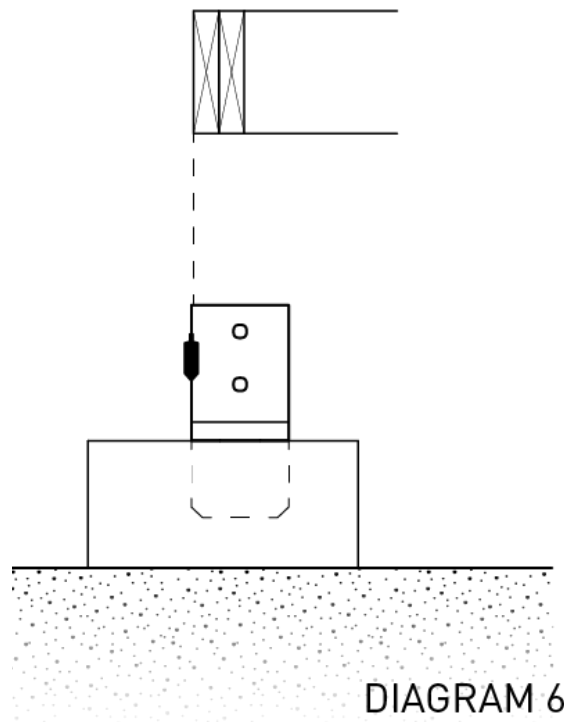

DIAGRAM 6

## Install Piers

- Double check that the temporary bracing has not moved and that the frame is both at the correct height and level
  - Adjust as needed
- Piers will be cut from 6x6 posts
- For each pier, measure from the top of the floor frame to where the 6x6 will sit in the bracket (See Diagram 7)
  - Cut 6x6 to this length using a circular saw set to maximum depth, rotating the post and making passes on all sides until cut is all the way through
- Cut notches so that the outside of the 6x6 is flush with the outside of the floor frame and the remainder extends up to the top of the floor frame
  - For piers in the corner, a 2 ½"x2 ½" piece will remain (See Diagrams 8A and 8B)
  - For intermediate piers, a 2 ½"x5 ½" piece will remain (See Diagrams 8C and 8D)
  - The height of the notches should match the height of the joists
  - To cut notches, plunge cut with a circular saw and complete cuts with a reciprocating saw or a hand saw
- Pre-drill holes and install lag screws from the outside of the frame into the notch that is extending up
  - Use 2 lag screws each time a post meets the frame (See Diagrams 8A and 8C)
  - Use ¾"x6 ½" galvanized lag screws

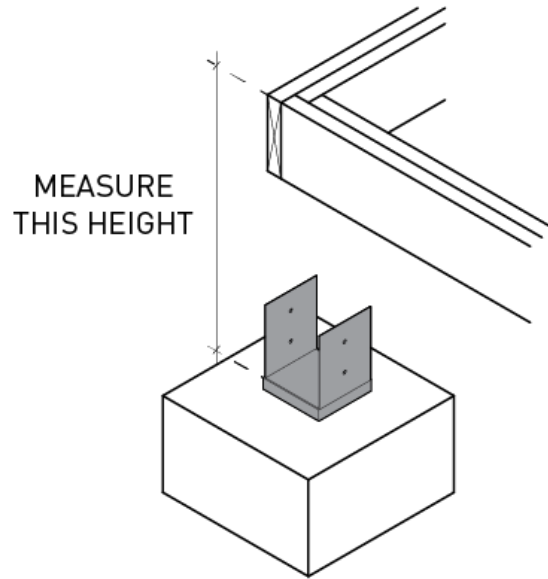

DIAGRAM 7

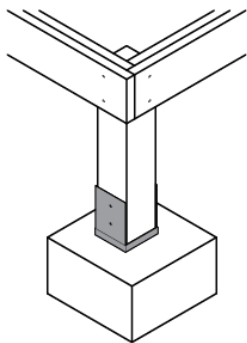

DIAGRAM 8-A



DIAGRAM 8-B

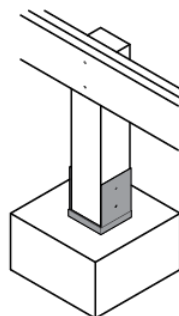

DIAGRAM 8-C

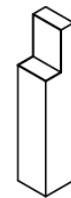

DIAGRAM 8-D

## **Install Common Joists** (See Diagram 9)

- Joists will run perpendicular to the band joist/perpendicular to the long sides of the addition
- Install common joists every 16" on center
- Crown each common joist, making sure that its natural arch is facing up
- Measure and install each common joist
  - Can toe-screw joist into place to hold it still or just hold it in place
- Add a joist hangers on each end of joists
  - Use joist hanger nails in holes on the flat surface and 2 ½" deck screws through the diagonal holes

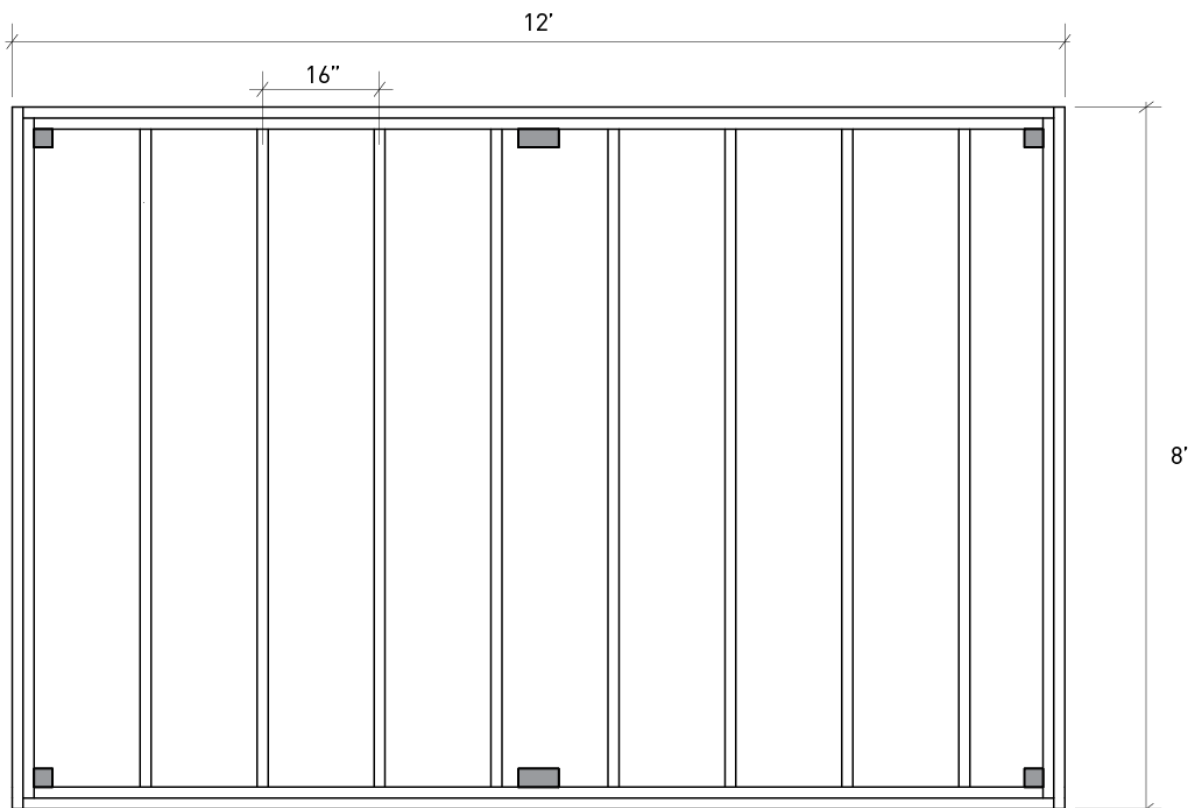

DIAGRAM 9

## **Install Subfloor**

- See installation directions on page 45

## **Frame and Stand Walls**

- See building and standing instructions on page 65
- For room additions the required minimum height of the outside wall is 84 ½”
  - After the double top plate and the bottom plate, the minimum stud height is 80”
- The bottom of the window should be a minimum of 18” above the floor
- Wall height
  - For additions to mobile homes, all four walls should be built to the same height
  - For additions to homes with rafters under the eaves, the interior wall should be at a height to support the rafters and the other three should be at the same height
- Do not forget to frame interior door(s) and window(s)
- Consider the pitch of the roof and how the new roof will tie into the old when determining the wall height
  - For additions onto mobile homes, rafters will likely have to extend up onto the existing roof and be scribed and cut at an angle to match the slope of the existing roof
  - For houses, the rafters may either rest underneath the existing overhang or extend up onto the existing roof and create a transition from the existing roof (tin roofing and transition flashing can be used in this situation)
  - For additions on the gable side of a house, flashing will have to be installed under the existing siding where the new roof attaches to the side of the house

## **Install Rafters**

- Roof over room addition will be a shed roof, with a single slope
- Determine the size of the rafters based on the span chart on page 90
  - Generally, 2x8s should be adequate
- Rafters for room additions to mobile homes
  - The rafters will run from just below the peak of the mobile home room to 12” past the exterior wall of the addition
  - Install a 1x4 ledger on the mobile home roof 2’ below the peak to receive and distribute the weight of the rafters (See Diagram 10)
    - 1x4 should be fastened into the mobile home trusses with deck screws
    - Ends of 1x4 should end on trusses if possible (this may not be possible at each end)
    - 1x4 should be installed the width of the room addition

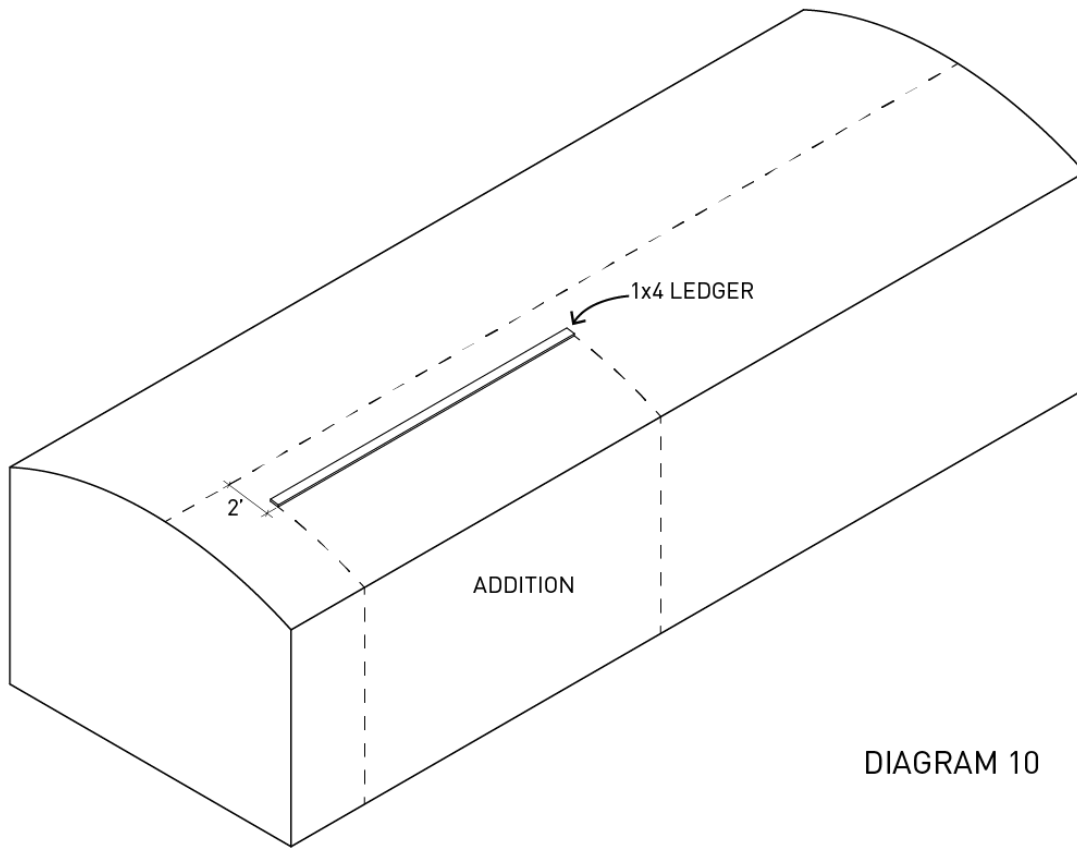

DIAGRAM 10

- Scribe the profile of the roof onto the rafter (See Diagram 11A)
  - Put the first rafter into place with a corner just below the peak of the mobile home roof and the other end sitting on a block that is on top of the outside wall, the block should be the same width as the rafters
  - Take an additional block the same size as the rafter and use it to trace the shape of the roof onto the rafter
- Cut the shape in the rafter from scribing using a jig saw if the line is curved or a circular saw if the line is straight
- Put the rafter into place with the small, cut end just below the peak and the other end resting directly on top of the exterior wall (See Diagram 11B)
  - Mark where the rafter sits on the 1x4 ledger
    - Notch out the shape of the 1x4 so that the cut profile of the rafter will sit directly on the mobile home roof
- After the notch is cut, put the rafter back into place and measure and mark a plumb, 12" overhang (See Diagram 11B)
- Make the plumb cut and use this rafter as a template to mark and cut the remainder of the rafters

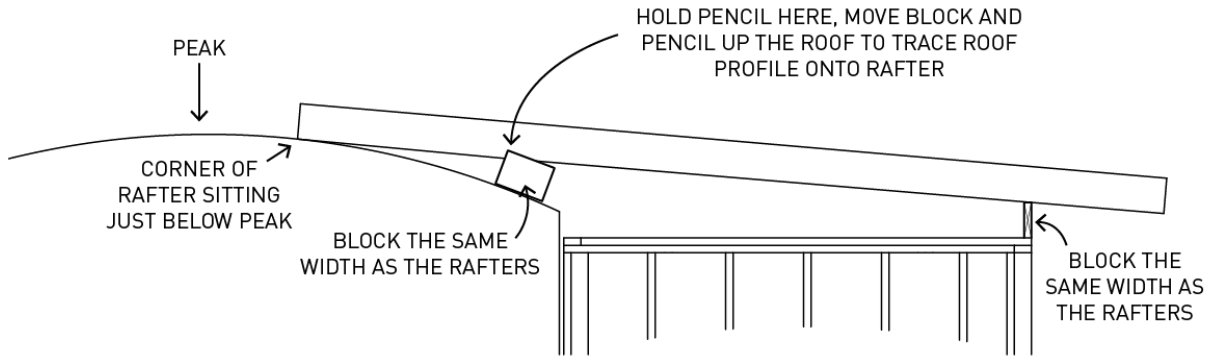

DIAGRAM 11-A

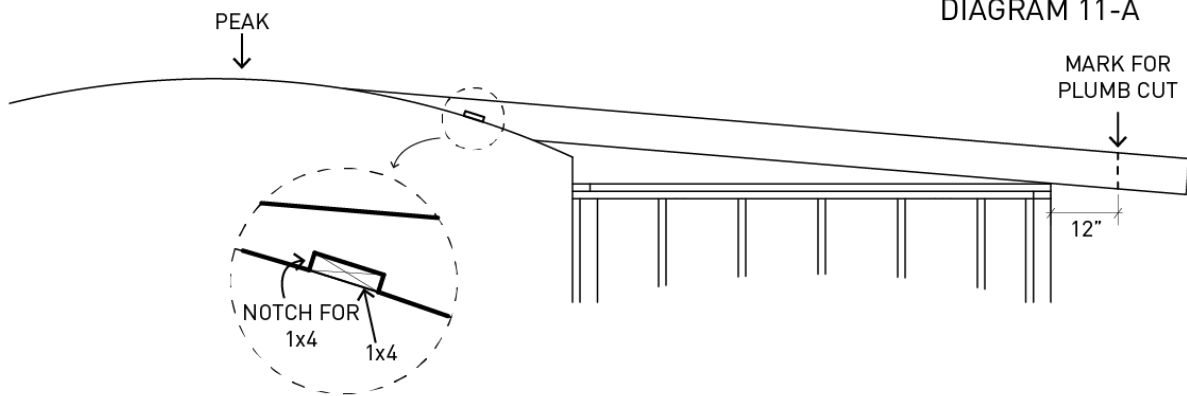

DIAGRAM 11-B

- Install the rafters 16" on center
  - Where the rafters sit on top of the addition's exterior wall, they should be attached with hurricane straps, filling 3 holes in each face of the hurricane strap with joist hanger nails (See Diagram 12)
  - Blocks will be added that attach the rafters to the new interior wall of the room addition (instructions below)
  - Pre-drill and toe-screw through the rafter into the 1x4 ledger to hold the top of the rafters into place
- The outside rafters should be installed so that the outside of the rafter will be flush with the sheathing of the wall when installed (See Diagram 12B)

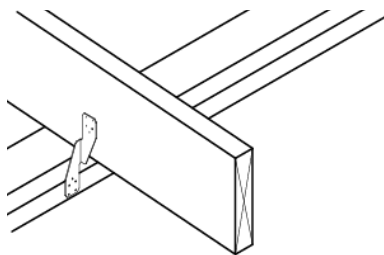

DIAGRAM 12-A

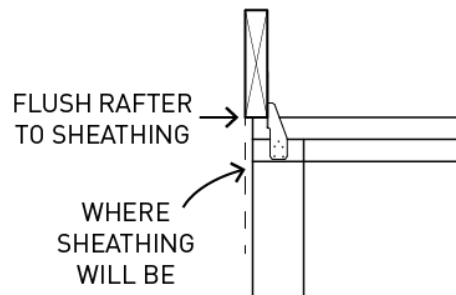

DIAGRAM 12-B

- Rafters to room additions on houses
  - If the rafters will be installed underneath the eave of the home: (See Diagram 13)
    - The rafters should rest on top of the interior wall that is built against the house and on top of the outside wall
    - Both ends of the rafter should be cut plumb
    - There should be a 12" overhang at the eave
    - Find the correct angles on one rafter and then use it as a template to mark and cut the additional rafters
    - Rafters should be installed 16" on center
    - Rafters should be fastened to both walls with hurricane ties, 3 joist hanger nails into each face of the hurricane tie
    - The two outside rafters should be installed to fall flush with the sheathing of the wall, account for this installing rafters because the walls not have been sheathed yet
  - If the rafters will extend up on to the roof, work with your construction consultant or HRC to make a plan for attaching the rafters to the existing roof

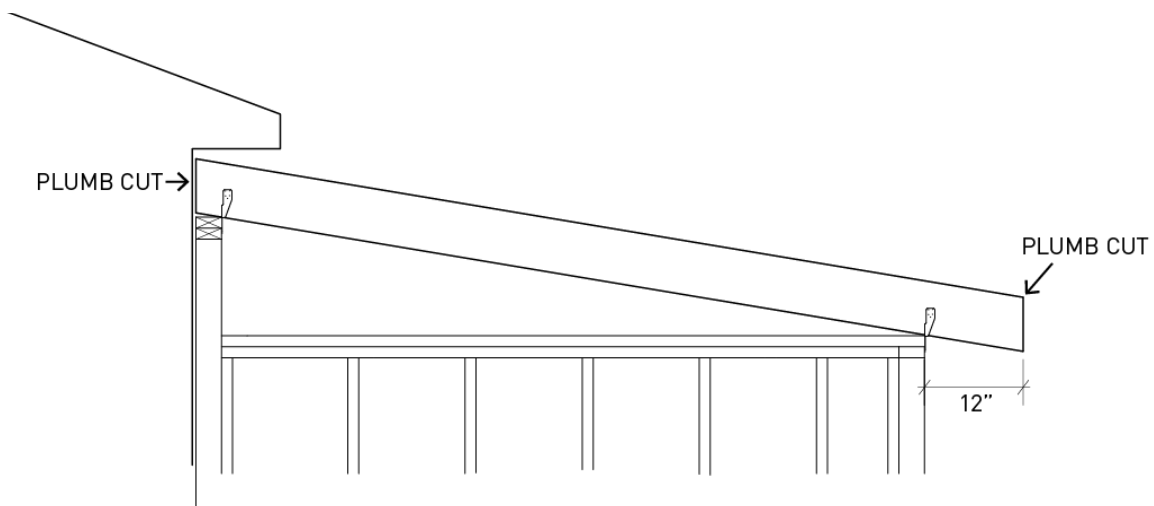

DIAGRAM 13

## Sheath Walls

- Once the walls are sheathed, (until the room is dried in) the hole for the window will be the access to the inside of the room
- Blocks
  - Install blocks between the two side walls and the outside rafters
    - These will act as nailers for both sheathing and drywall
  - If there is space between the rafters and the interior wall, blocks should be added here too
  - To install (See Diagram 14)
    - Install over studs so that the spacing remains the same
    - Trace the angle onto the pieces and toe-screws into place
    - Find and cut angles with miter saw
- Detailed sheathing instructions can be found on page 73
- Carry sheathing from bottom of floor frame to bottom of outside rafter, top of sheathing will be cut at an angle

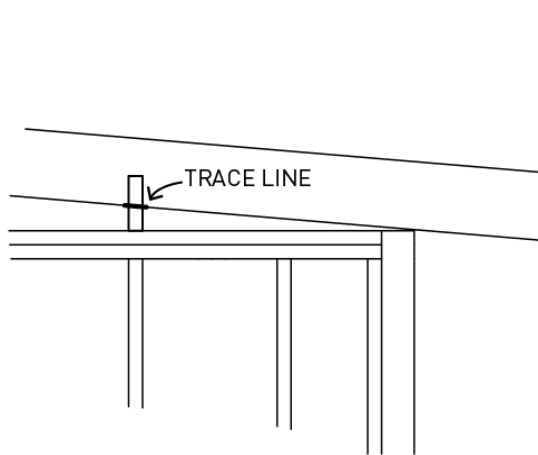

DIAGRAM 14-A

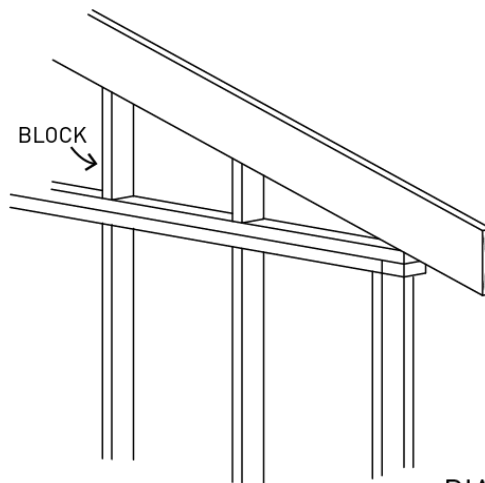

DIAGRAM 14-B

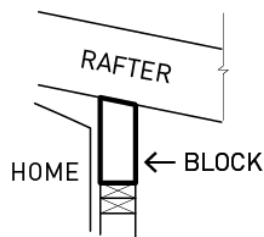

DIAGRAM 14-C



## Install Flashing

- For additions to mobile homes, flashing needs to be installed where the walls and roofline of the addition meet the existing structure
- For additions to homes, flashing only needs to be installed where the new walls intersect the old
- Wall to wall connection (See Diagram 15)
  - Bend a piece of flashing that will extend from 2" below the bottom of the floor frame to 6" above the eave (for mobile homes) or extends up to the top of the rafter (for additions to homes with new roofline under existing overhang)
    - At least 6" needs to extend onto the existing siding
    - If there is a mobile home gutter, it needs to be cut 3"-4" away from the intersection of the walls and that 3"-4" section should be pounded down
    - Bend the flashing in half lengthwise using a straight edge to help create the corner
    - Cut 6" down the middle of the bend on one end, bend one tab down and out 90° (this tab will extend over the roof )
  - Apply a generous bead of silicone caulk to the back of the edge that will rest on the siding of the new structure
  - Put the flashing into place, bending the tab over the roof
  - Fasten to the existing wall with neoprene screws every 8" (or more often if needed to match profile of siding)
  - Fasten into the new sheathing every 12"-18" with roofing nails
  - Add another bead of silicone caulk at edge of flashing over existing siding after it is fastened
  - Do not fasten tab into the roof

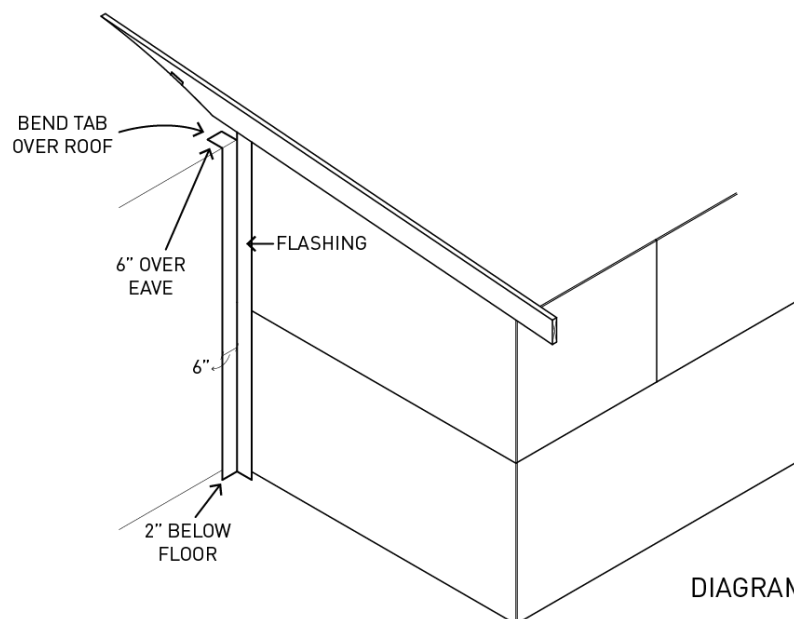

DIAGRAM 15

- Roof to roof flashing (See Diagram 16)
  - Bend a piece of flashing lengthwise that will extend from the top of the addition rafters to 3" past the eave
    - At least 6" should extend out onto the roof
    - Use wide enough flashing that it will extend up the majority of the side of the rafter
  - Put this piece in place and trace where the flashing extends above the new roof
    - Cut this line using tin snips
  - Tack the flashing into the rafter every 12" using roofing nails, do not tack into the existing roof
  - A length of SBS roofing material should be cut that runs from the top of the rafter to 3" past the eave
    - The SBS will extend at least 12" out onto the roof and run up the side of rafter, covering the flashing
    - SBS should extend above the addition roof all the way to the eave, trim this excess off with a hook blade
    - Use the SBS roller, to roll the SBS onto mobile home roof, flashing, and rafter to help it adhere

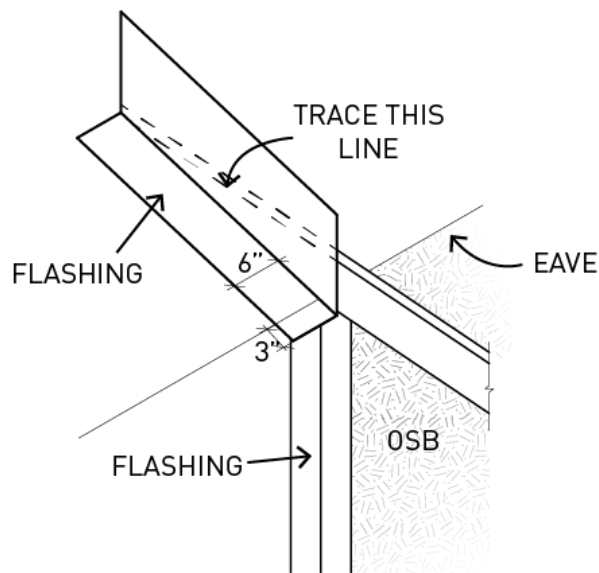

DIAGRAM 16-A

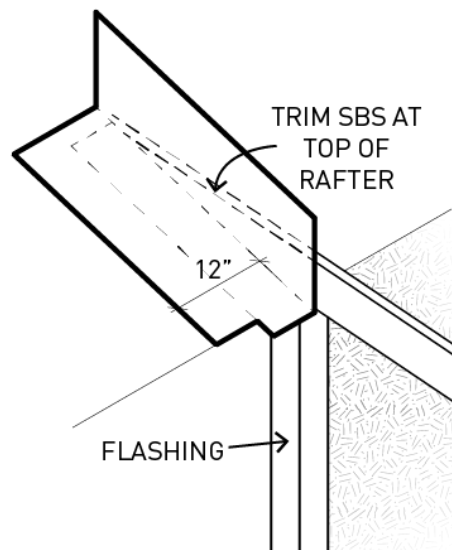

DIAGRAM 16-B

## **Build Out Overhang** (See Diagram 17)

- An overhang will be built out on sloped sides of the room addition
- Install a pressure treated 2x4 on the outside of the exterior rafters
  - Cut to match profile of rafters at the top and the plumb cut at the bottom
  - Fasten into the rafter (over the SBS) with 3" screws
- Install a 2x6 on the outside of the 2x4
  - Cut to match profile of rafters at the top and the plumb cut at the bottom
  - Fasten into the 2x4 with 3" screws
- This creates an opening where the j-channel for the top of the siding will rest (j-channel won't be installed until later)

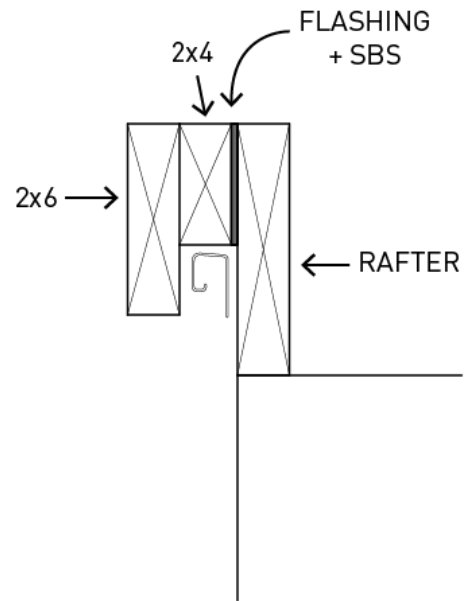

DIAGRAM 17

## **Install Fascia Board** (See Diagram 18)

- Install a 2x8 fascia board across the front of the rafter tails
  - This will cover the ends of the 2x6 and 2x4 overhangs that were just installed

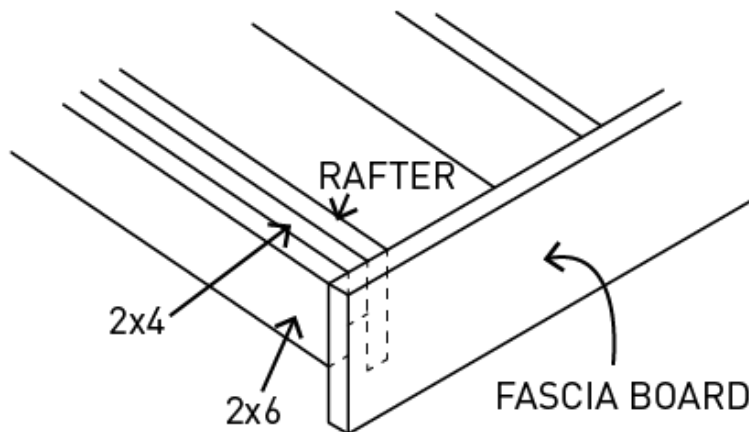

DIAGRAM 18

## Deck Roof

- Instructions for installing roof decking are on page 92
- If SBS roof covering will be used **do not install H-clips**
- Extend the OSB slightly past the end of the rafters at the top if that will help ease the transition

## Install Metal Fascia on Gable Sides Only

- Attach metal fascia over the outside of the 2x6 on both angled sides of the roof
- Install with white aluminum trim nails attached every 18", one over the other

## SBS Roof Covering

- Instructions for SBS roof covering are on page 111
- Instructions for tin roof covering are on page \_\_\_\_
- If using SBS on an addition to a mobile home, leave excess on each edge to be attached underneath termination bar, but do not attach termination bar until metal fascia has been installed
  - Soffit across the eave side has to be installed before metal fascia
  - SBS can be left overhanging temporarily and fastened down later
- Carry the last piece of SBS over the peak of the roof and extend 12" past the overhang on each end (See Diagram 19)

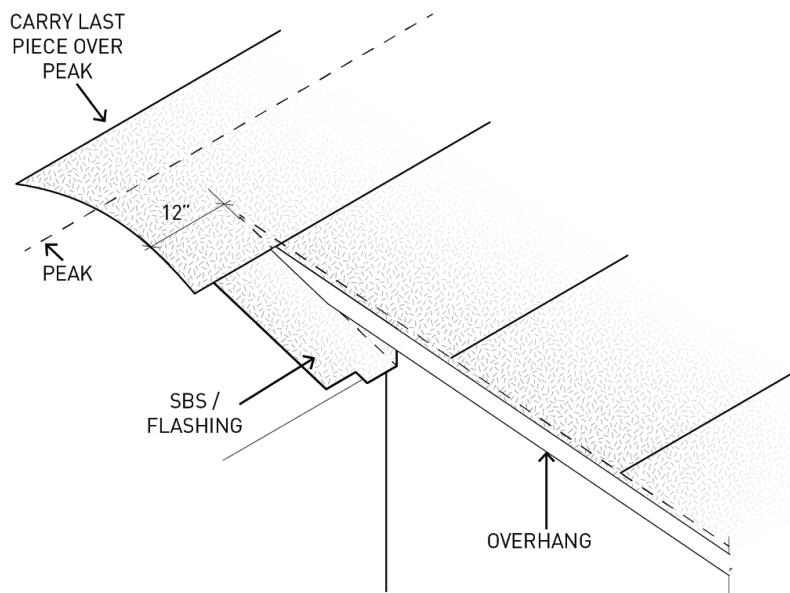

DIAGRAM 19

## **Housewrap:**

- See installation instructions on page 146

## **Cut Door Opening into Home**

- If coming through an existing window, remove the window
- Cut away siding from the opening from the addition side and drywall away from the interior
- Remove interfering studs and re-frame opening as needed

## **Install Window:**

- See installation instructions on page 78

## **Vinyl Soffit/Metal Fascia:**

- See installation instructions for vinyl soffit and metal fascia on page 146
- The termination bar across the eave needs to be installed after the metal fascia is installed

## **Vinyl Siding:** Instructions for installing vinyl siding are on page 151

- On gable sides, j-channel will be installed into the gap of the overhang created by the 2x4 and 2x6 at the top of the wall

## **Subcontractor(s) (Plumbing and Electric):**

- This is the point in the room addition process that electricians and plumbers should come do the rough-ins
- Do not complete the remaining items until the plumbing/electric is run because it will interfere with their ability to complete work

## **Insulate:**

- See installation instructions for insulation on page 167

## **Underpinning:**

- See installation instructions for underpinning installation on page 221

## **Set Shower/Tub Base:**

- See product installation instructions

## **Drywall (Install and Finish):**

- See instruction for drywall installation and finishing are on page 175

## **Install and Trim Interior Door** (See Diagram 20)

- A prehung interior door will be used, the door will swing into the room
- Additional studs may need to be added to the wall of the existing house or mobile home to create the door frame
  - A header should be built and installed over this new doorway in the existing wall
- If the addition is to a mobile home, the door will likely be taller than the wall of the mobile home (which is okay, because the door will swing into the room)
  - This will require some extra trim at the top of the opening
- Install pre-hung door (detailed directions on page 82)
- 1x material can be ripped to width with a table saw and used to meet up to the pre-hung door frame, install 1x with finish nails (this can be done on both sides and the top if possible)
- Install door casing around the door inside the existing home

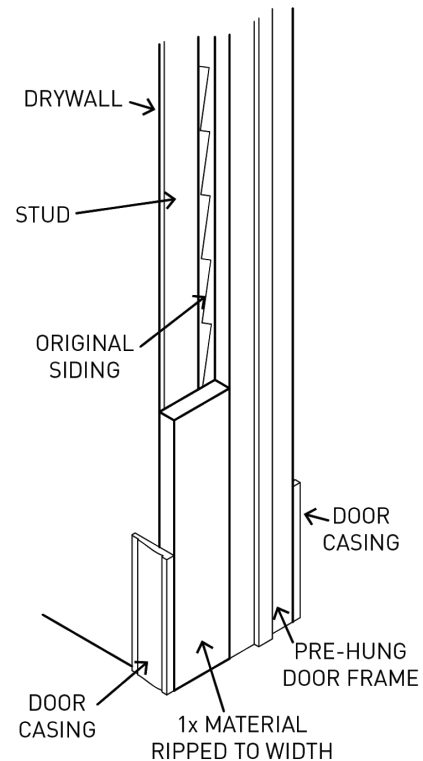

DIAGRAM 20

## **Prime/Paint:**

- See instructions for priming/painting on page 189

## **Install Finished Floor:**

- See installation instructions for finished flooring installation on page 54

## **Set Light fixtures/heaters/toilet/vanity**

## **Trim:**

- See installation instructions for trim on page 197
- Including baseboard and trim around windows

## Room Addition Materials List

|   |  | Quantities for:        |                               |  |  |                        |
|---|--|------------------------|-------------------------------|--|--|------------------------|
| Item:   | Purpose:                                       | 8'x12'<br>Bed-<br>room | 8'x24'<br>Two<br>Bed-<br>room | 8'x20'<br>Bed-<br>room<br>and<br>Bath-<br>room | 8'x10'<br>Acces-<br>sible<br>Bath-<br>room | 5'x5'<br>Bath-<br>room |
| 2x8x8 *<br><small>*If within 18" from grade<br/>PT is recommended</small> | Common Joist and Double Rim Joist              | 12                     | 21                            | 18   | 10   | X                      |
| 2x8x8*  | Double Band Joist                              | X                      | 6                             | X  | X  | X                      |
| 2x8x12*   | Double Band Joist                              | 4                      | 4                             | X  | X  | X                      |
| 2x8x10*   | Double Band Joist                              | X                      | X                             | 4  | 4  | 2                      |
| 2x8x10*   | Common Joist and Double Rim Joist              | X                      | X                             | X  | X  | 4                      |
| 60lb bags<br>Concrete   | Footers (10-12 bags per hole)                  | ~ 60                   | ~ 80                          | ~ 80   | ~ 60                                       | ~ 40                   |
| 2x8x12 WW   | Boxes Over Footers                             | 3                      | 4                             | 4  | 3  | 2                      |
| 6x6x___ PT  | Piers (depending on height of existing home)   | ___                    | ___                           | ___  | ___  | ___                    |
| 3/4" OSB  | Subfloor                                       | 3                      | 6                             | 6  | 3  | 2                      |
| 2x4x8 WW  | Top/Bottom Plate                               | 6                      | 6                             | 6  | 6  | X                      |
| 2x4x12 WW   | Top/Bottom Plate                               | 6                      | 12                            | X  | X  | X                      |
| 2x4x10 WW   | Top/Bottom Plate                               |                        |                               | 12   | 6  | 5                      |
| 2x4 Studs   |  | 45-50                  | 68-75                         | 58-65  | 40-45                                      | 25-30                  |
| 2x10x___ WW   | Header Material (depending on width of window) | ___                    | ___                           | ___  | ___  | ___                    |
| 1x4x8 WW  | Ledger to receive rafters                      | 2                      | 3                             | 3  | 2  | 1                      |
| 2x8x16 WW   | Rafters  | 10                     | 19                            | 16   | 9  | X                      |
| 2x8x12 WW   | Rafters  | X                      | X                             | X  | X  | 5                      |

|   |   |     |     |     |     |     |
|---|---|-----|-----|-----|-----|-----|
| 7/16" OSB   | Wall Sheathing, Roof Decking, Header Material | 14  | 24  | 20  | 14  | 9   |
| 2x4x8 PT  | Gable Side Overhang                           | 4   | 4   | 4   | 4   | 3   |
| 1x6x8 PT  | Gable Side Overhang                           | 4   | 4   | 4   | 4   | 3   |
| 6x6 Post Brackets                                 | Connect Piers to Footers                      | 6   | 8   | 8   | 6   | 4   |
| 3/8" x 7" Galvanized Carriage Bolts/Washers /Nuts | Connect Piers to Floor System                 | 20  | 24  | 24  | 20  |     |
| 2x8 Joist Hangers                                 |   | 16  | 34  | 28  | 12  | 8   |
| Hurricane Ties                                    | Connect Rafters to Exterior Wall              | 10  | 19  | 16  | 9   | 5   |
| Flashing  | Between existing home/roof and new room/roof  | 40' | 40' | 40' | 40' | 40' |
| Pre-hung Interior Door                            |   | 1   | 2   | 2   | 1   | 1   |
| Window (Must be egress in bedrooms)               |   | 1   | 2   | 2   | 1   | 1   |
| Toilet  |   | X   | X   | 1   | 1   | 1   |
| Shower/Tub/ Surround                              |   | X   | X   | 1   | 1   | 1   |
| Sink/Vanity                                       |   | X   | X   | 1   | 1   | 1   |

**For additional materials see lists and recommended tools from specific sections (siding, roofing, drywall, etc.).**



## Photo Credits

- "0.152' x 6' Strong-Tie SDWC Truss Plate Structural Screw, Orange Zinc." *Fasteners Plus*, [www.fastenersplus.com/0.152-x-6-Strong-Tie-SDWC-Truss-Plate-Structural-Screw-Orange-Zinc?quantity=1&package-quantity=25&gclid=Cj0KCQjw1-fvBRC3ARIsAlifYOM2JEhxyLmfh1Z7UBhuVdC7IQMB-9iDxDGcM0\\_qp7w1KznagWdD6YaAphWEALw\\_wcB](http://www.fastenersplus.com/0.152-x-6-Strong-Tie-SDWC-Truss-Plate-Structural-Screw-Orange-Zinc?quantity=1&package-quantity=25&gclid=Cj0KCQjw1-fvBRC3ARIsAlifYOM2JEhxyLmfh1Z7UBhuVdC7IQMB-9iDxDGcM0_qp7w1KznagWdD6YaAphWEALw_wcB).
- "10-Inch 15 Amp Compact Table Saw ." *Home Depot*, [www.homedepot.ca/en/home/p.10-inch-15-amp-compact-table-saw.1000534294.html](http://www.homedepot.ca/en/home/p.10-inch-15-amp-compact-table-saw.1000534294.html).
- "#11 x 2-1/2 In. 8-PennyHot-Galvanized Spiral Shank Deck Nails (5 Lb.-Pack)." *Home Depot*, [www.homedepot.com/p/Grip-Rite-11-x-2-1-2-in-8-PennyHot-Galvanized-Spiral-Shank-Deck-Nails-5-Lb-Pack-8HGSTPD5/202308532](http://www.homedepot.com/p/Grip-Rite-11-x-2-1-2-in-8-PennyHot-Galvanized-Spiral-Shank-Deck-Nails-5-Lb-Pack-8HGSTPD5/202308532).
- "1-1/4' WHITE STAINLESS STEEL TRIM NAILS 50 LB BOX." *Nail Plant.Com*, [www.nailplant.com/WHITE\\_STAINLESS\\_STEEL\\_TRIM\\_NAILS\\_p/n72298475.htm](http://www.nailplant.com/WHITE_STAINLESS_STEEL_TRIM_NAILS_p/n72298475.htm).
- "18 V Impactor™ Fastening Driver - Tool Only." *Bosch*, [www.boschtools.com/us/en/boschtools-ocs/impact-drivers-25618-132465-p/](http://www.boschtools.com/us/en/boschtools-ocs/impact-drivers-25618-132465-p/).
- "#2 Phillips Power Bit, 1/4' Hex Power Drive." *Grainger*, [www.grainger.com/product/5RDJ5?cm\\_mmc=PPC:+Google+PLA&s\\_kwcid=AL12966!3!166595776055!!!s!88854183477!&ef\\_id=Wrrb5AAAMLigzT4l:20180328022249:s](http://www.grainger.com/product/5RDJ5?cm_mmc=PPC:+Google+PLA&s_kwcid=AL12966!3!166595776055!!!s!88854183477!&ef_id=Wrrb5AAAMLigzT4l:20180328022249:s).
- "#2 Phillips x 1" Drywall Dimpler Insert Bit." *Rockler*, [www.rockler.com/2-phillips-x-1-drywall-dimpler-insert-bit](http://www.rockler.com/2-phillips-x-1-drywall-dimpler-insert-bit).
- "28 Ft. Fiberglass Extension Ladder." *Best Materials*, [www.bestmaterials.com/detail.aspx?ID=9476](http://www.bestmaterials.com/detail.aspx?ID=9476).
- "3 In. 32-Teeth per in. T-Shank Jig Saw Blade (5-Pack)." *Home Depot*, [www.homedepot.com/p/Makita-3-in-32-Teeth-per-in-T-Shank-Jig-Saw-Blade-5-Pack-792475-4/204374294](http://www.homedepot.com/p/Makita-3-in-32-Teeth-per-in-T-Shank-Jig-Saw-Blade-5-Pack-792475-4/204374294).
- "3-1/4' Tapcon Cement / Masonry Screws (Phillips Drive)." *Screw Products Inc*, [screw-products.com/cement-board-and-tapcon-cementmasonry-screws/](http://screw-products.com/cement-board-and-tapcon-cementmasonry-screws/).
- "4 In. 6 TPI U Shank High Carbon Steel Jig Saw Blade." *Home Depot*, [www.homedepot.com/p/Milwaukee-4-in-6-TPI-U-Shank-High-Carbon-Steel-Jig-Saw-Blade-48-42-0200/203176201](http://www.homedepot.com/p/Milwaukee-4-in-6-TPI-U-Shank-High-Carbon-Steel-Jig-Saw-Blade-48-42-0200/203176201).
- "5-Lb 11-Gauge 2-in Steel Roofing Nails ." *Lowe's*, [www.lowes.com/pd/5-lb-11-Gauge-2-in-Steel-Roofing-Nails/4744107](http://www.lowes.com/pd/5-lb-11-Gauge-2-in-Steel-Roofing-Nails/4744107).
- "#6 x 1-1/4 In. Philips Bugle-Head Coarse Thread Sharp Point Drywall Screws (1 Lb.-Pack)." *Home Depot*, [www.homedepot.com/p/Grip-Rite-6-x-1-1-4-in-Philips-Bugle-Head-Coarse-Thread-Sharp-Point-Drywall-Screws-1-lb-Pack-114CDWS1/100152392](http://www.homedepot.com/p/Grip-Rite-6-x-1-1-4-in-Philips-Bugle-Head-Coarse-Thread-Sharp-Point-Drywall-Screws-1-lb-Pack-114CDWS1/100152392).
- "8 In. x 8 in. 14-Gauge Rough Adjustable Post Base." *Home Depot*, [www.homedepot.com/p/8-in-x-8-in-14-Gauge-Rough-Adjustable-Post-Base-ABU88R/203262546](http://www.homedepot.com/p/8-in-x-8-in-14-Gauge-Rough-Adjustable-Post-Base-ABU88R/203262546).
- "Abrasive Cut-Off Wheels for Metal Cutting (Flat) 14' x 1/8' x 1." *ArcherUSA*, [www.dexpan.com/abrasive-cut-off-wheels-for-metal-cutting-amc114a.aspx](http://www.dexpan.com/abrasive-cut-off-wheels-for-metal-cutting-amc114a.aspx).
- A-Frame Ladder*. [toolrentaldepot.com/index.php?id\\_product=232&controller=product&id\\_lang=1](http://toolrentaldepot.com/index.php?id_product=232&controller=product&id_lang=1).
- "Bosch 3/4-in x 8-in SDS-Plus Drill Bit ." *Lowe's*, [www.lowes.com/pd/Bosch-3-4-in-x-8-in-SDS-Plus-Drill-Bit/1091905](http://www.lowes.com/pd/Bosch-3-4-in-x-8-in-SDS-Plus-Drill-Bit/1091905).
- "Carriage Bolt ." *Lowe's*, [jguDpgPrNwUdp2EQO6suQZP2FOoFwLmU52beaYkE1yfnL5kaAhpqEALw](http://jguDpgPrNwUdp2EQO6suQZP2FOoFwLmU52beaYkE1yfnL5kaAhpqEALw).
- "Circular Saw Blade." *ToolTech*, [tooltechvietnam.com/en/san-pham/circular-saw-blade/](http://tooltechvietnam.com/en/san-pham/circular-saw-blade/).
- Club, Fix-It. "Circular Saw." *Howstuffworks*, 15 Mar. 2007, [home.howstuffworks.com/circular-saw.htm](http://home.howstuffworks.com/circular-saw.htm).
- "Common Round Galvanized Iron Wire Nails ." *Anping Hainauan Wire Mesh Co., Ltd* , [www.hncwiremesh.com/products/common-nail.html](http://www.hncwiremesh.com/products/common-nail.html).
- "DEWALT 12-in 15-Amp Dual Bevel Compound Miter Saw ." *Lowe's*, [www.lowes.com/pd/DEWALT-12-in-15-Amp-Dual-Bevel-Compound-Miter-Saw/1007577](http://www.lowes.com/pd/DEWALT-12-in-15-Amp-Dual-Bevel-Compound-Miter-Saw/1007577).
- "Diagram of Nail Sizes ." *The HobbitHouse Illustrated Glossary of Woodworking Terms* , [www.hobbithouseinc.com/personal/woodpics/\\_g\\_NO.htm](http://www.hobbithouseinc.com/personal/woodpics/_g_NO.htm).
- "Dormer Drill Bit Dormer Jobber Drill Bit Mm Plain Shank Dormer Drill Bits Uk." *2SISTEMI.ME*, [www.2asistemi.me/dormer-drill-bit/dormer-drill-bit-dormer-jobber-drill-bit-mm-plain-shank-dormer-drill-bits-uk/](http://www.2asistemi.me/dormer-drill-bit/dormer-drill-bit-dormer-jobber-drill-bit-mm-plain-shank-dormer-drill-bits-uk/).
- "Fas-n-Tite 5-Lb 9-Gauge 1.5-in Hot-Dipped Galvanized Smooth Joist Hanger Nails ." *Lowe's*, [www.lowes.com/pd/Fas-n-Tite-5-lb-9-Gauge-1-5-in-Hot-Dipped-Galvanized-Smooth-Joist-Hanger-Nails/50423202](http://www.lowes.com/pd/Fas-n-Tite-5-lb-9-Gauge-1-5-in-Hot-Dipped-Galvanized-Smooth-Joist-Hanger-Nails/50423202).
- "Finish Nail, 305SS, 2 1/2 In.PK3650 ." *Grainger*, [www.grainger.com/product/GRAINGER-APPROVED-Finish-Nail-3KDW9](http://www.grainger.com/product/GRAINGER-APPROVED-Finish-Nail-3KDW9).
- "Galvanized Ring Shank Nails for Permanent Constructions." *Ruiwanda*, [www.galvanizednails.net/nails/ring-shank-nails.html](http://www.galvanizednails.net/nails/ring-shank-nails.html).
- "HeadLok." *Fasten Master*, [www.fastenmaster.com/products/headlok-heavy-duty-flathead-fastener.html](http://www.fastenmaster.com/products/headlok-heavy-duty-flathead-fastener.html).
- "Hex Bit Profile ." *IFIXIT*, [www.ifixit.com/Store/Tools/1-5mm-Hex-Screwdriver/IF145-025-2](http://www.ifixit.com/Store/Tools/1-5mm-Hex-Screwdriver/IF145-025-2).
- "HILLMAN FASTENERS 48420 25 Lb 10x3 Tan Deck Screw ." *Amazon*, [www.amazon.com/HILLMAN-FASTENERS-48420-10x3-Screw/dp/B0100INGJ8](http://www.amazon.com/HILLMAN-FASTENERS-48420-10x3-Screw/dp/B0100INGJ8).
- "Hitachi 8-1/2-in-Tooth Circular Saw Blade ." *Lowe's*, [www.lowes.com/pd/Hitachi-8-1-2-in-Tooth-Circular-Saw-Blade/1018551](http://www.lowes.com/pd/Hitachi-8-1-2-in-Tooth-Circular-Saw-Blade/1018551).
- "LedgerLok." *Fasten Master*, [www.fastenmaster.com/products/ledgerlok-ledger-board-fastener.html](http://www.fastenmaster.com/products/ledgerlok-ledger-board-fastener.html).
- "LENOX 3-in Bi-Metal Arbored Hole Saw ." *Lowe's*, [www.lowes.com/pd/LENOX-3-in-Bi-Metal-Arbored-Hole-Saw/3361292](http://www.lowes.com/pd/LENOX-3-in-Bi-Metal-Arbored-Hole-Saw/3361292).
- Lier, Pam. "Electric Drill." *Lampert Lumber*, [www.lampertlumber.com/blog/lumber/5-power-tools-for-beginner-woodworkers/](http://www.lampertlumber.com/blog/lumber/5-power-tools-for-beginner-woodworkers/).
- "Mobile Home - Manufactured Housing - RV ." *Mobile Home Depot* , [mobilehomedepotmi.com/general/help-desk.html](http://mobilehomedepotmi.com/general/help-desk.html).
- "Neoprene Screw." *All Points Fasteners* , [www.allpointsfasteners.com/Polebarn-Screws.html](http://www.allpointsfasteners.com/Polebarn-Screws.html).
- "Phillips Bits." *Tool Cobbler* , [www.toolcobber.com.au/power-tools/drilling/accessories/screwdriver-bits/](http://www.toolcobber.com.au/power-tools/drilling/accessories/screwdriver-bits/).
- "Rain Gutter Diagram ." *Interstate Material Supply* , [interstatematerialsupplyaz.com/products/](http://interstatematerialsupplyaz.com/products/).
- "Reciprocating Saw." *Doityourself*, [www.doityourself.com/stry/6-best-uses-for-a-reciprocating-saw](http://www.doityourself.com/stry/6-best-uses-for-a-reciprocating-saw).
- "Red Head 5/8' x 6' Galvanized Wedge Anchor WS-5860G." *Boltsnutsandtools.com*, [www.boltsnutsandtools.com/galvanized-c-311\\_312\\_313\\_316/red-head-58-x-6-galvanized-wedge-anchor-ws5860g-p-1495.html](http://www.boltsnutsandtools.com/galvanized-c-311_312_313_316/red-head-58-x-6-galvanized-wedge-anchor-ws5860g-p-1495.html).
- "Simple Value Jigsaw - 350W." *Argos*, [www.argos.co.uk/product/7110948](http://www.argos.co.uk/product/7110948).
- "Simpson Strong Tie Simpson Strong Tie TP37 3-1/8-Inch by 7-Inch Tie Plate ." *Amazon*, [www.amazon.com/Simpson-Strong-Tie-TP37-3-1-8-inch-7-inch/dp/B000W162SO](http://www.amazon.com/Simpson-Strong-Tie-TP37-3-1-8-inch-7-inch/dp/B000W162SO).
- "Spade Bit ." *Lowe's*, [www.lowes.com/projects/woodworking-and-crafts/drill-bits-buying-guide/article](http://www.lowes.com/projects/woodworking-and-crafts/drill-bits-buying-guide/article).
- "T25 Torx, 1/4' Hex Drive Torx Bit." *MSC*, [www.mscdirect.com/product/details/06688071](http://www.mscdirect.com/product/details/06688071).
- "TEC SCREW HEX DRIVER BIT M8 200130020." *Samuel Kirk BM Ltd*, [www.samuelkirk.co.uk/tec-screw-hex-driver-bit-m8-200130020-12920-p.asp](http://www.samuelkirk.co.uk/tec-screw-hex-driver-bit-m8-200130020-12920-p.asp).
- "Torx Bits ." *Tool Cobbler* , [www.toolcobber.com.au/power-tools/drilling/accessories/screwdriver-bits/](http://www.toolcobber.com.au/power-tools/drilling/accessories/screwdriver-bits/).
- "Z-MAX 2 in. x 8 in. Galvanized Double Shear Face Mount Joist Hanger." *Home Depot*, [www.homedepot.com/p/Simpson-Strong-Tie-Z-MAX-2-in-x-8-in-Galvanized-Double-Shear-Face-Mount-Joist-Hanger-LUS28Z/100374921](http://www.homedepot.com/p/Simpson-Strong-Tie-Z-MAX-2-in-x-8-in-Galvanized-Double-Shear-Face-Mount-Joist-Hanger-LUS28Z/100374921).
- "Z-MAX Galvanized 18-Gauge Hurricane Tie." *Home Depot*, [www.homedepot.com/p/Simpson-Strong-Tie-Z-MAX-Galvanized-18-Gauge-Hurricane-Tie-H2-5AZ/100275721](http://www.homedepot.com/p/Simpson-Strong-Tie-Z-MAX-Galvanized-18-Gauge-Hurricane-Tie-H2-5AZ/100275721).